



LAND/P serie BioG



BERTI:

A NAME YOU CAN TRUST

EXPERIENCE

Since 1959, we have been manufacturing machines for the maintenance and reclamation of green spaces in urban, agricultural and forestry areas. Over the years we have built our brand on the reliability and durability of our equipment.

INNOVATION

In 2018 we inaugurated a new 36,000 sqm facility that reflects all the characteristics of modern production by meeting the requirements of Industry 4.0 and guaranteeing optimised production, storage and shipment of machines.

VALUES

We are a Family that with Collaboration and Trust produces hundreds of pieces of equipment every day.

We have strong Ethics that require us to follow the highest quality standards and the Responsibility to provide every customer with the right equipment for their needs.

We look to the future with Confidence and Energy to never stop being at your side in your daily work.





WHAT IS BIOMASS?

The term 'biomass' refers to renewable raw materials that are obtained from the waste and residues of agricultural, livestock and forestry activities, as well as from crops specifically intended for energy production.

Biomass is one of the largest renewable resources available.

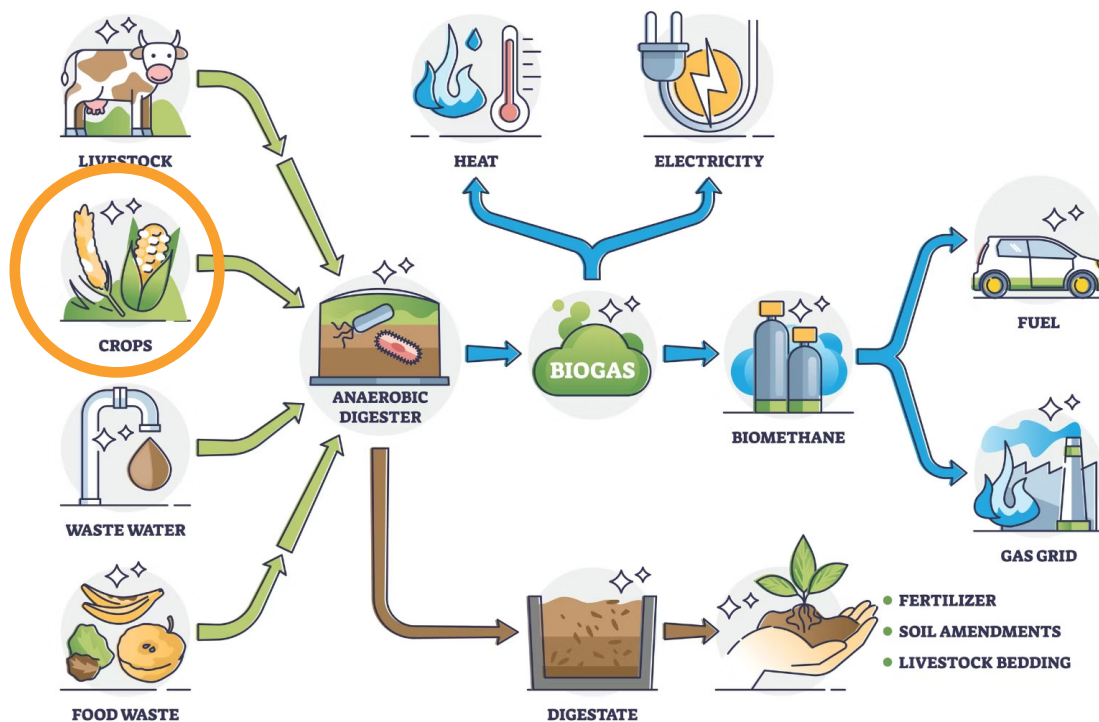

Bioenergy plants produce electricity by means of steam generated by burning agricultural, industrial and municipal waste.

The materials are burnt in a combustion chamber, producing the heat necessary to transform the water in the thermodynamic circuit into steam.

Biomass, therefore, is a key resource in today's increasingly conscious use of energy.



WHY FIELD RESIDUES, STRAW AND MANURE?

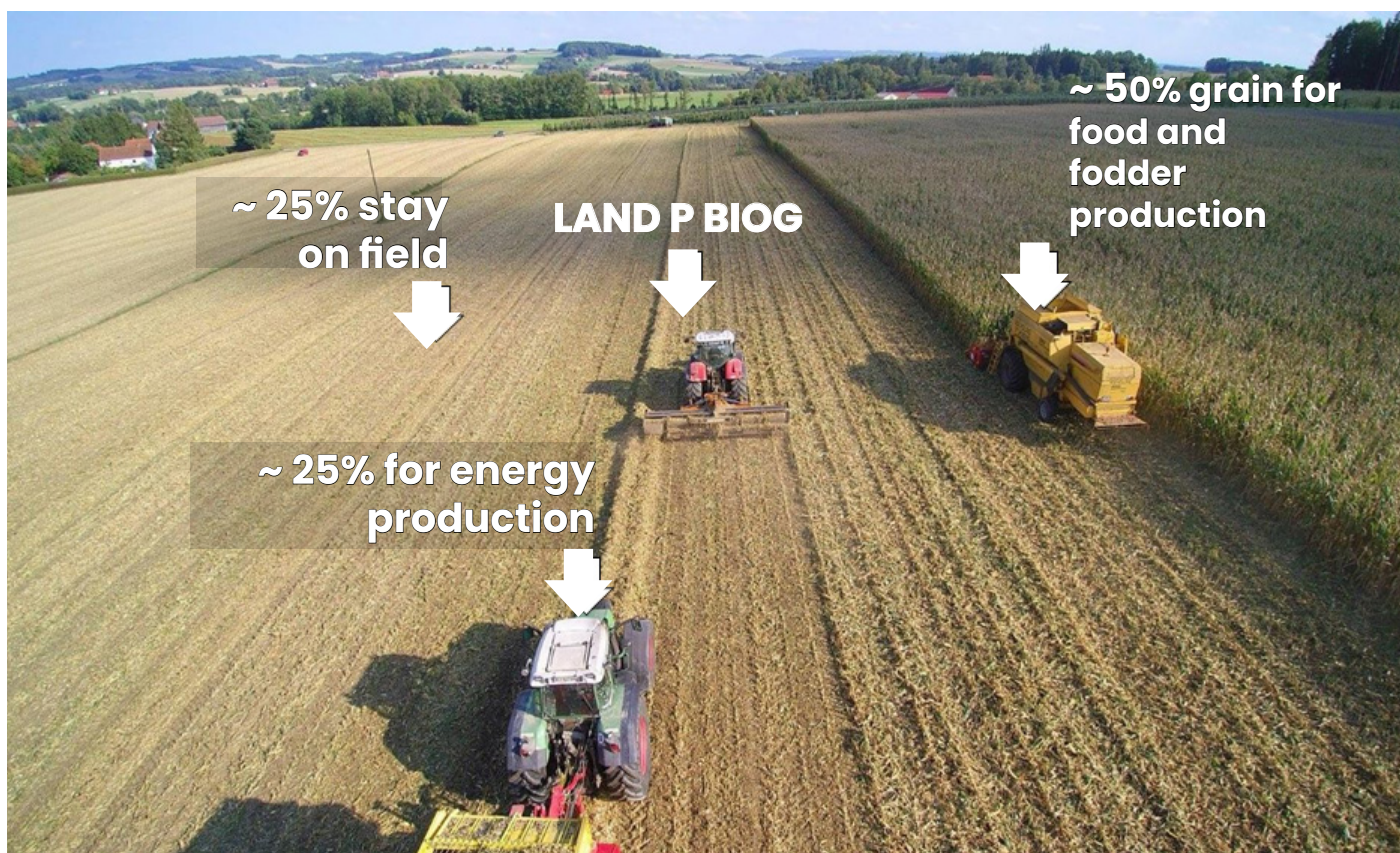

4 good reasons

No fungi or pests in plant cultivation



Preservation of nutrients



Reduction of climate-damaging gases



Easier soil tillage



A NEW FRONTIER FOR RENEWABLE ENERGY



LAND/P serie BioG



200-380 HP

LAND/P BioG is the new stalks shredder that joins the BERTI agricultural range.

Recommended for shredding and recovering agricultural by-product, the Land/P BioG makes it possible to cut, mulch and swath crop residues in a single operation.

In addition to being used for energy purposes, the recovery of the agricultural by-product can also ensure a number of positive effects on crops and soil such as:

- active reduction of pests
- less disease and mould in subsequent crops
- improved nutrient management.

MOD.													
	cm	Min	Max	n°	n°		A	B	C	D	E	min	max
LAND/ P BioG 600	600	200	380	72	5+5	540	330	245	248	635	160	4400	4600

OPERATION

Plant residue is cut by entering the front of the machine. The mulched material is deposited onto the conveyor belt at the rear of the machine.

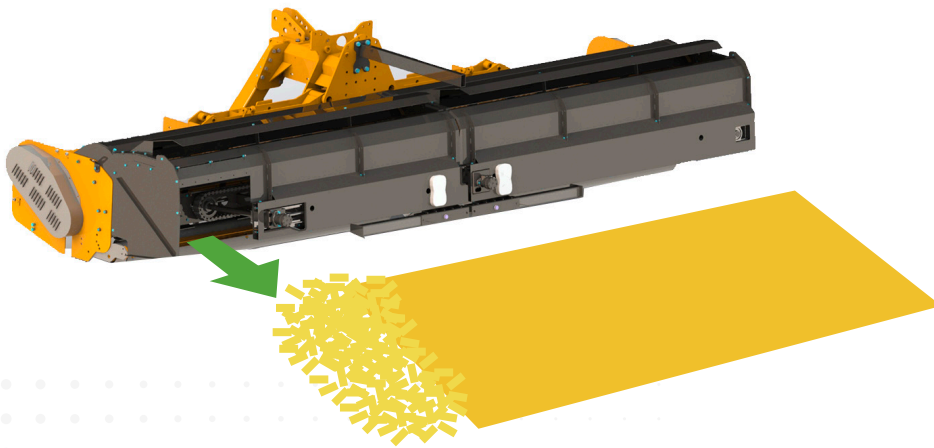
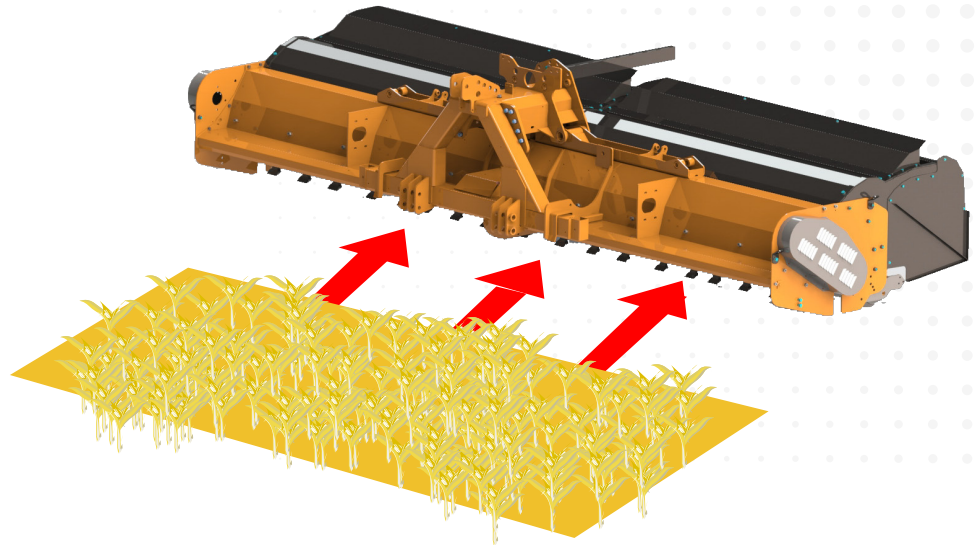

The belt conveys the entire mulched material to the left side, discharging it onto the ground and at the same time forming a swath that will facilitate the easy pickup.



HOW TO USE PLANT RESIDUES?

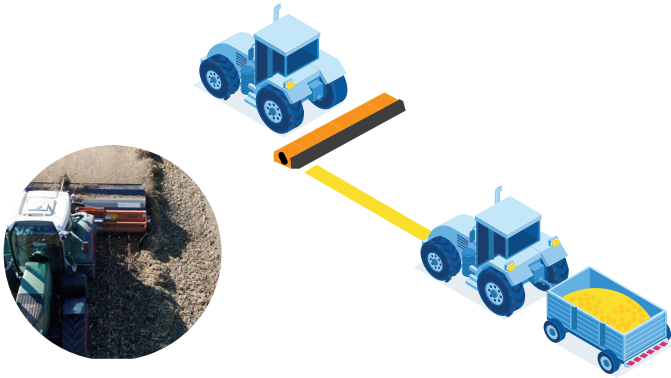

MULCHING AND HARVESTING

The plant residues are mulched and discharged on the left side of the Mulcher. The mulched material is then collected using a loader.

TRANSPORT AND STORAGE

The mulched material is collected with a loader and transported to a collection area where it is combined with other harvested plant residue.

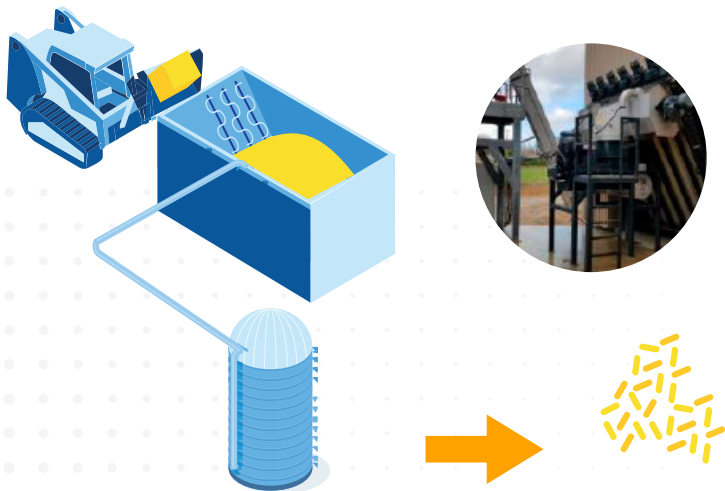
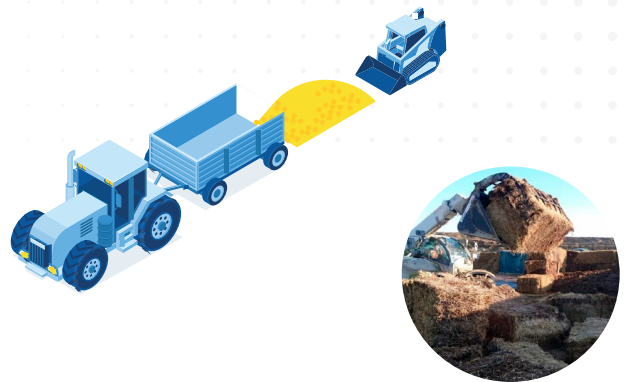

PREPARATION

The field residue is fed into the fermenter where it undergoes various processes: dosed, defibrillated, mixed and pumped.

STOPPING

In the fermenter of the biogas plant, the field residues of the bacteria are broken down and transformed into biomethane, also releasing the CO₂ absorbed by the plant during its life.



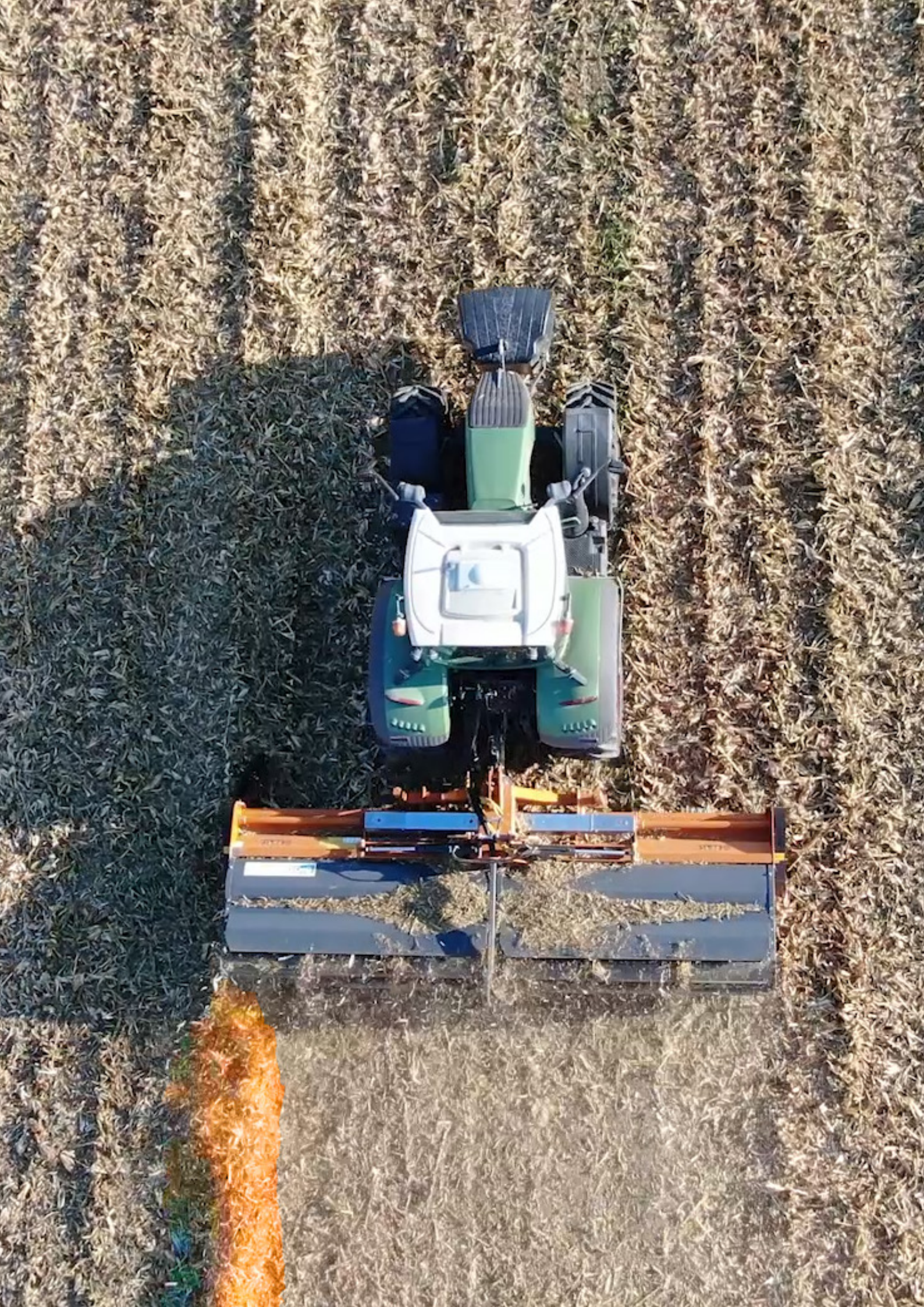

STANDARD EQUIPMENTS

BIGGER REAR ROLLER WITH SCRAPER

Thanks to its shape and size, it supports the machine in all conditions, even on wet ground.

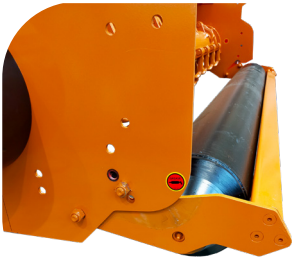

LED HEADLIGHTS

Integrated into the frame, ensuring durability and maximum visibility

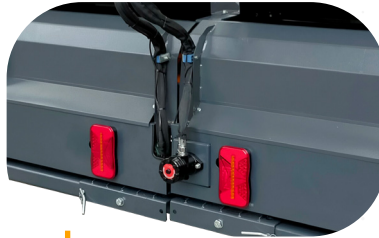

SUPPORT FEET FOR PARKING

Allows the machine to be stored in the transport position taking up as little space as possible..

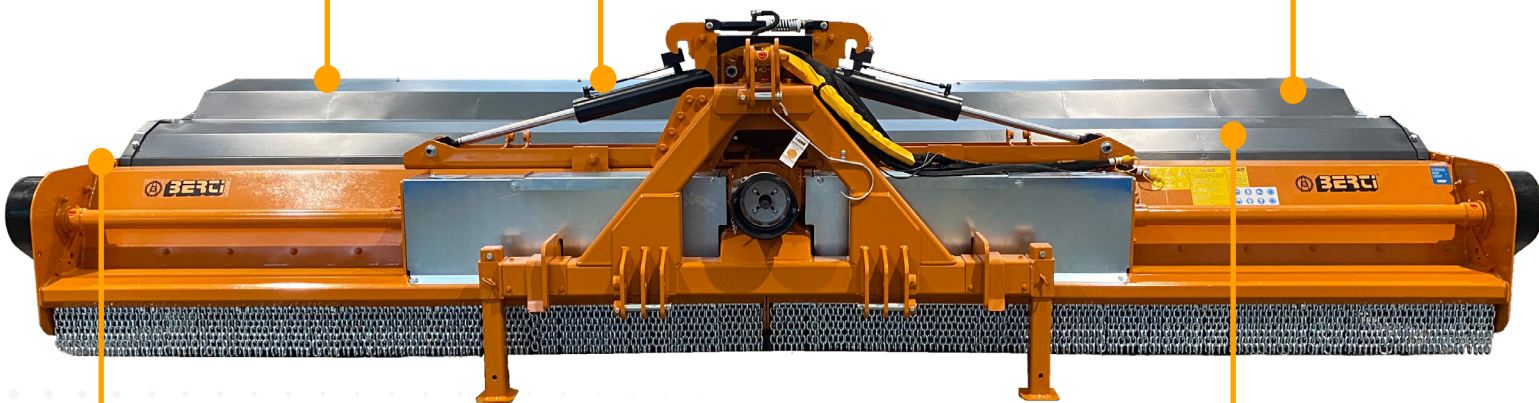

FULL AUTOMATIC BELTS ADJUSTER

It guarantees maximum available power and greatly reduces maintenance.

visuale interna

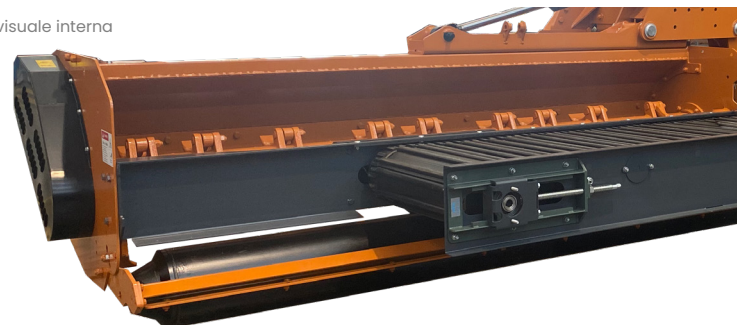

CONVEYOR BELT

It consists of interchangeable modules. It serves to convey mulched material sideways and forms a swath.

TECHNICAL TIPS

More advantages for fast and precise work



Conveyor construction:

- 2x fibre reinforced straps
- Steel rods with hole pattern
- Rivets and screws

The rubber band is riveted and screwed to the 2 fabric straps using steel braces.

It is screwed in one position and is used for:

- Assembly
- Maintenance work on the machine
- Changing components

HYDRAULIC CYLINDERS VALVE

safety valve that guarantees total control of the opening and closing of the machine.



RELEASE SYSTEM

Road transport safety system automatically activated in sequence by the machine opening/closing movement.

PRODUCTIVITY and PERFORMANCE

YIELD PER HECTARE WITH FIELD RESIDUE

Material	Yield t/ha	Gas yield NI CH ₄ /t TS	Saving oil (lt)	Saving CO ² (t)
Corn straw	3-8 t/ha	230-320	800-2500	3-8
Cereal straw	3-8 t/ha	170-210	500-1700	2-5
Rape straw	2-5 t/ha	180-230	350-1150	1-4
Intercrops	3-8 t/ha	220-280	650-2200	2-7

HARVESTING COSTS* PER HA OF MAIZE STRAW

Collection yield for a 2km radius	3,5 ha/h
Land P BioG	120€/h
2 wagons self-loading	240€/h
Processing in silos	60€/h
Harvest costs per ha	120€/ha
Collection costs per t TS (a 4,1t TS/ha)	29,3€/t TS
Collection costs per m ³ CH ₄ (a 290m ³ CH ₄ /t TS)	0,101€/m ³ CH ₄
Collection costs per Mwh of electricity (at 40% el)	25,2€/Mwh el

ENERGY BALANCE PER HA OF MAIZE STRAW

Fuel consumption for a radius of 2km	3,5 ha/h
Land P BioG	29 lt/h
2 wagons self-loading	54 lt/h
Processing in silos	12 lt/h
Fuel consumption per ha	27 lt/ha
Fuel consumption per t TS (a 4,1t TS/ha)	6,6 lt/t TS
Potential oil savings per ha of maize straw (a 4,1t TS/ha)	1.190 lt/ha
% of energy required for straw collection and storage	2,3%

*estimation calculated in Austria in 2021





BERTI AND BioG: EXPERIENCE, PROFESSIONALISM AND EXPERTISE.



BioG GmbH is a modern Austrian company specialising in the conception, design and construction of industrial biogas plants. Thanks to its own patents, it is able to build plants with very high efficiency and using the most diverse organic materials.

Each plant is kept under control at all times, even remotely, thanks to sensors and software specially designed and developed by BIOG, to guarantee customers the best assistance and safety.

BERTI's long experience in the field of manufacturing mulchers combined with BioG's experience in the field of producing biomass plants in a conscious manner has led to the creation of the LAND/P series BioG model.

But when we talk about 'biomass' what do we mean?

The term 'biomass' refers to renewable raw materials that are obtained from the waste and residues of agricultural, livestock and forestry activities, as well as from crops specifically intended for energy production.

Biomass is one of the largest renewable resources available.

Bioenergy plants produce electricity by means of steam generated by burning agricultural, industrial and municipal waste.

The materials are burnt in a combustion chamber, producing the heat necessary to transform the water in the thermodynamic circuit into steam. Biomass, therefore, is a key resource in today's increasingly conscious use of energy.





LAND/P serie BioG



www.bertima.it

follow us on:



BERTI[®]

BERTI MACCHINE AGRICOLE SPA
VIA MUSI 1/A - 3 - 4 37042 - CALDIERO (VR)
TEL: 045 6139 711 - info@bertima.it
P.IVA E C.F. 00068150234
www.bertima.it