



**BERTI**<sup>®</sup>  
MACCHINE AGRICOLE

**TFB/L**  
**TFB/LR**  
**ZETA**  
**TFB/Y**  
**TFB/YE**  
**TFB/C**  
**TFB/REV**  
**TFB/M**  
**TFB/ME**



**Trinciatutto da vigneto e frutteto per trattori da 40 a 180 HP**



**Mulchers for vineyard and orchard for tractors from 40 to 180 HP**



**Mulchgeräte für Wein- und Obstbau für Traktoren von 40 bis 180 PS**



**Broyeurs à vignobles et vergers pour tracteurs de 40 a 180 CV**



**Trituradoras para viñedos y frutales para tractores de 40 a 180 CV**





- Rullo livellatore regolabile con pulirullo e rastrelli raccoglitori.
- Adjustable and levelling roller, with scraper and rakes.
- Einstellbare Stützwalze mit Abstreifer und Sammelrechen.
- Rouleau palpeur réglable avec décrotoir et râteaux ramasseurs.
- Rodillo nivelador con rascador y rastrillos recogedores.

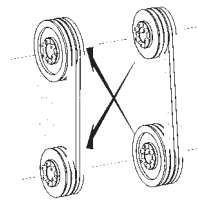
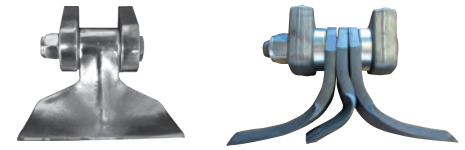

**Optional**

- PTO 540/1000 g/min (invertendo le pulegge).
- PTO 540/1000 rpm (reversing the pulleys).
- Getriebe 540 oder 1000 U/min (Umkehrbare Riemenscheibe).
- PDF 540/1000 t/min (en inversant les poulies).
- PTO 540/1000 g/min (invirtiendo las poleas).

**OPTIONALS**

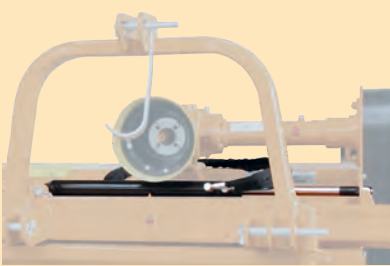

- Spostamento idraulico con tubi e innesti rapidi.
- Hydraulic side shift with hoses and quick couplings.
- Hydraulische Seitenverschiebung.
- Déport hydraulique avec tuyaux et prises rapides.
- Desplazamiento hidráulico.



- Rullo posteriore livellatore con diametro maggiorato (Ø 159mm).
- Rear levelling roller with big diameter (Ø 159mm).
- Heck- Stuetzwalze mit grossem Durchmesser (Ø 159mm).
- Rouleau niveleur arrière avec majeur diamètre (Ø 159mm).
- Rodillo nivelador trasero de mayor diámetro (Ø 159mm)



- Albero cardanico.
- Pto drive shaft.
- Gelenkwelle.
- Arbre cardan.
- Cardan.

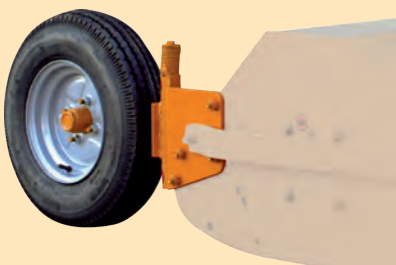

- Kit ruote sterzanti.
- Steering wheels.
- Satz Hinterlenkräder.
- Jeu roues directrices.
- Ruedas directrices.



- Slitte di appoggio.
- Skids.
- Satz Kufen.
- Jeu patins.
- Patines.



- Ruote frontali stabilizzatrici, regolabili in altezza.
- Front wheels kit.
- Regulierbare Stützräder für Frontanbau.
- Jeu roues frontales.
- Ruedas frontales estabilizadoras y regulables en altura.





- Rullo livellatore regolabile con pulirullo e rastrelli raccoglitori.
- Adjustable and levelling roller, with scraper and rakes.
- Einstellbare Stützwalze mit Abstreifer und Sammelrechen.
- Rouleau palpeur réglable avec décrotoir et râteaux ramasseurs.
- Rodillo nivelador con rascador y rastrillos recogedores.

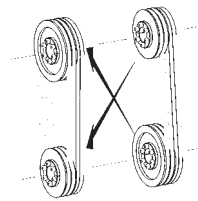
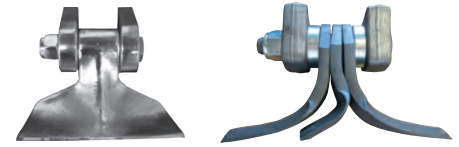

#### Optional

- PTO 540/1000 g/min (invertendo le pulegge).
- PTO 540/1000 rpm (reversing the pulleys).
- Getriebe 540 oder 1000 U/min (Umkehrbare Riemenscheibe).
- PDF 540/1000 t/min (en inversant les poulies).
- PTO 540/1000 g/min (invirtiendo las poleas).

## OPTIONALS



- Spostamento idraulico con tubi e innesti rapidi.
- Hydraulic side shift with hoses and quick couplings.
- Hydraulische Seitenverschiebung.
- Déport hydraulique avec tuyaux et prises rapides.
- Desplazamiento hidráulico.



- Rullo posteriore livellatore con diametro maggiorato (Ø 159mm).
- Rear leveling roller with big diameter (Ø 159mm).
- Heck- Stuetzwalze mit grossem Durchmesser (Ø 159mm).
- Rouleau niveleur arrière avec majeur diamètre (Ø 159mm).
- Rodillo nivelador trasero de mayor diámetro (Ø 159mm)



- Albero cardanico.
- Pto drive shaft.
- Gelenkwelle.
- Arbre cardan.
- Cardan.



- Slitte di appoggio.
- Skids.
- Satz Kufen.
- Jeu patins.
- Patines.

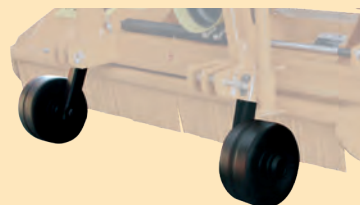

- Ruote frontali stabilizzatrici, regolabili in altezza.
- Front wheels kit.
- Regulierbare Stützräder für Frontanbau.
- Jeu roues frontales.
- Ruedas frontales estabilizadoras y regulables en altura.

# ZETA



Trinciatrice da frutteto e vigneto per erba e sarmenti da applicare a trattori con potenza compresa tra 60 e 100 HP.



Mulcher for vineyard and orchard, suited to mulch grass, bushes, pruning and branches for tractors from 60 to 100 HP.



Mulchgerät für Wein- und Obstbau, für Traktoren von 60 bis 100 PS. Es eignet sich zum Mulchen von Gras, Büsche und Äste.



Broyeur à vignobles et vergers indiqué pour broyer l'herbe, les buissons, les sarments et les tiges pour tracteurs de 60 à 100 CV.



Trituradora para viñedos y frutales apta para triturar hierba, sarmientos y residuos de madera para tractores con una potencia entre 60 y 100 CV.

**STRENX®**  
PERFORMANCE STEEL



- Attacco ai tre punti spostabile meccanicamente su tubi cromati, Cat. II.
- Displaceable 3-points linkage, on chromate tubes, Cat. I-II (mechanical).
- Versetzbarer Dreipunktbock, Kat. I-II (mechanischer).
- Attelage déportable à 3 points, Cat. I-II, avec tuyaux chromés (mécanique).
- Eganche a los tres puntos movable sobre tubos cromados, Cat. I-II (desplazamiento mecánico).



- Tenditori automatici delle cinghie.
- Full automatic belts adjusters.
- Automatische Riemenspannungen.
- Tendeurs automatiques des courroies.
- Tensores automáticos de las correas.



- Doppia trasmissione centrale a cinghie.
- Double and central belts transmission.
- Doppelter und mittiger Keilriemenantrieb.
- Double et central transmission par courroies.
- Doble transmisión central con correas.

Mod.													
	I ↔ I	Min	Max	mm	n°	n°	n°	PTO	A	B	C	min	max
<b>ZETA 150</b>	150	60	100	940   560 560   940	8+8	24+24	3+3	540 (1000)	96	152	160	690	800
<b>ZETA 170</b>	170	60	100	1040   660 660   1040	8+8	24+24	3+3	540 (1000)	96	172	160	740	850
<b>ZETA 190</b>	190	60	100	1140   760 760   1140	10+10	30+30	3+3	540 (1000)	96	192	160	790	900
<b>ZETA 210</b>	210	70	100	1240   860 860   1240	10+10	30+30	3+3	540 (1000)	96	212	160	840	950
<b>ZETA 230</b>	230	70	100	1340   960 960   1340	12+12	36+36	3+3	540 (1000)	96	232	160	890	1000
<b>ZETA 250</b>	250	70	100	1440   1060 1060   1440	12+12	36+36	3+3	540 (1000)	96	252	160	940	1050



- Tirante terzo punto.
- Top link tie-rod.
- Oberlenk Zugstange.
- Tige de renfort au troisième point.
- Tirante de refuerzo.



- Rullo livellatore regolabile con pulirullo.
- Adjustable and levelling roller, with scraper.
- Einstellbare Stützwalze mit Abstreifer.
- Rouleau palpeur réglable avec décrotoir.
- Rodillo nivelador con rascador.



- Fiancate laterali prive di sporgenze.
- Chamfered and smooth sides of chassis
- Seitenbleche, ohne Vorsprungen.
- Côtés latéraux sans saillies
- Costados laterales sin salientes.

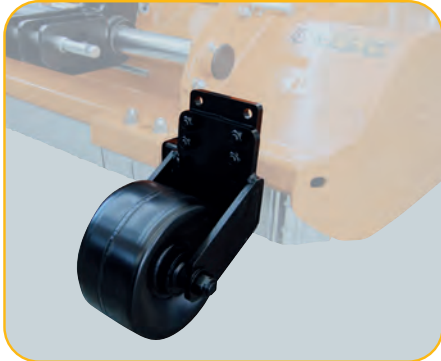

- Ruote fisse anteriori stabilizzatrici, regolabili in altezza.
- Height adjustable front and fixed wheels.
- Regulierbare und feste Stützräder für Frontanbau.
- Roues frontales fixes et réglables en hauteur.
- Ruedas frontales estabilizadoras fijas y regulables en altura.



Optional

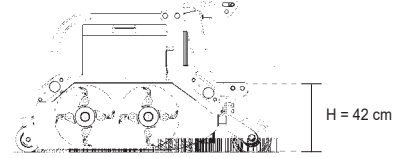

## OPTIONALS



- Spostamento idraulico con tubi e innesti rapidi.
- Hydraulic side shift with hoses and quick couplings.
- Hydraulische Seitenverschiebung.
- Déport hydraulique avec tuyaux et prises rapides.
- Desplazamiento hidráulico.



- Ruote in gomma fisse anteriori.
- Fixed rubber wheels, front mounted.
- Feste Gummistützräder vorne.
- Roues frontales fixes en caoutchouc.
- Ruedas delanteras fijas de goma.



- Ruote in gomma pivotanti anteriori (per uso frontale)
- Pivoting rubber wheels, front mounted (for front use)
- 360° schwenkbare Gummistützräder vorne (für Frontanbau)
- Roues pivotantes frontales en caoutchouc (pour utilisation frontale)
- Ruedas pivotantes y delanteras en goma (Para uso frontal)



- Rastrelli raccoglitori (solo per uso posteriore).
- Collecting rakes (only for rear use).
- Sammelrechen (nur für Heckverwendung).
- Râteaux ramasseurs (ne que pour use arrière).
- Rastrillos recogedores (solo por uso posterior).



- Versione frontale.
- Front version.
- Front Version.
- Version avant.
- Versión delantera.



- Albero cardanico con ruota libera.
- PTO drive shaft with free wheel.
- Gelenkwelle mit Freilauf.
- Arbre cardan avec roue libre.
- Cardan con rueda libre.

# TFB/Y



Trinciatrice da frutteto e vigneto per erba, sarmenti e materiale legnoso fino a Ø 8 cm., da applicare a trattori con potenza compresa tra 60 e 110 HP.



Mulcher for vineyard and orchard, suited to mulch grass, bushes, pruning and branches up to Ø 8 cm. for tractors from 60 to 110 HP.



Mulchgerät für Wein- und Obstbau, für Traktoren von 60 bis 110 PS. Es eignet sich zum Mulchen von Gras, Büsche und Äste bis Ø 8 cm.



Broyeur à vignobles et vergers indiqué pour broyer l'herbe, les buissons, les sarments et les tiges allant jusqu'à Ø 8 cm, pour tracteurs de 60 à 110 CV.



Trituradora para viñedos y frutales apta para triturar hierba, sarmientos y residuos de madera en general de hasta 8 cm. de diámetro para tractores con una potencia entre 60 y 110 CV.

## HARDOX®

WEAR PLATE



- Attacco ai 3 punti spostabile meccanicamente, Cat. I-II.
- Displaceable 3 point linkage, Cat. I-II (mechanical).
- Versetzbarer Dreipunktbock, Kat. I-II (mechanischer).
- Attelage déportable à 3 points, Cat. I-II (mécanique).
- Enganche a los 3 puntos Cat. I-II (desplazamiento mecánico).



- Tenditore automatico delle cinghie.
- Full automatic belts adjuster.
- Automatische Riemenspannung.
- Tendeur automatique des courroies.
- Tensor automático de las correas.



- Fiancata destra arrotondata.
- Chamfered profile on the right-hand chassis' corner.
- Seitlich Abschrägung auf Mulcherrahmen.
- Coin côté droite arrondi.
- Perfil rebajado en la parte derecha.

Mod.													
	cm	Min	Max	mm	n°	n°	n°	PTO	A	B	C	min	max
<b>TFB/Y 120</b>	120	60	110	685   515 315   885	12	36	4	540 (1000)	100	140	120	560	720
<b>TFB/Y 140</b>	140	60	110	875   525 355   1045	12	36	4	540 (1000)	100	160	120	610	770
<b>TFB/Y 160</b>	160	60	110	875   725 355   1245	14	42	4	540 (1000)	100	180	120	660	840
<b>TFB/Y 180</b>	180	60	110	875   925 355   1445	16	48	4	540 (1000)	100	200	120	700	890
<b>TFB/Y 200</b>	200	80	110	875   1125 355   1645	18	54	4	540 (1000)	100	220	120	740	940
<b>TFB/Y 220</b>	220	80	110	1040   1160 520   1680	20	60	4	540 (1000)	100	240	120	790	990
<b>TFB/Y 250</b>	250	80	110	1040   1460 520   1980	22	66	5	540 (1000)	100	270	120	890	1100



H = 47 cm (120-220)  
H = 49 cm (250)

- Rullo livellatore regolabile con pulirullo e rastrelli raccoglitori.
- Adjustable and levelling roller, with scraper and rakes.
- Einstellbare Stützwalze mit Abstreifer und Sammelrechen.
- Rouleau palpeur réglable avec décrottoir et râteaux ramasseurs.
- Rodillo nivelador con rascador y rastrillos recogedores.

Optional

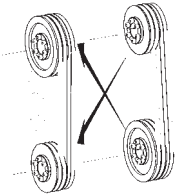

- PTO 540/1000 g/min (invertendo le pulegge).
- PTO 540/1000 rpm (reversing the pulleys).
- Getriebe 540 oder 1000 U/min (Umkehrbare Riemenscheibe).
- PDF 540/1000 t/min (en inversant les poulies).
- PTO 540/1000 g/min (invertiendo las poleas).

## OPTIONALS



- Spostamento idraulico con tubi e innesti rapidi.
- Hydraulic side shift with hoses and quick couplings.
- Hydraulische Seitenverschiebung.
- Déport hydraulique avec tuyaux et prises rapides.
- Desplazamiento hidráulico.



- Rullo posteriore livellatore con diametro maggiorato.
- Rear leveling roller with big diameter.
- Heck- Stuetzwalze mit grossem Durchmesser.
- Rouleau niveleur arrière avec majeur diamètre.
- Rodillo nivelador trasero de mayor diámetro.



- Attacco centrale.
- Centre mounted linkage.
- Mittiger Anbau.
- Attelage axial.
- Enganche central.

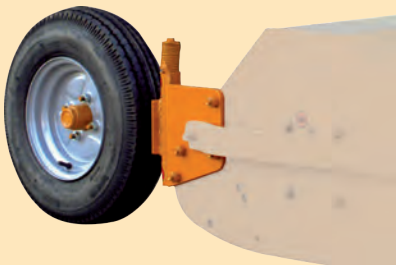

- Kit ruote sterzanti.
- Steering wheels.
- Satz Hinterlenkräder.
- Jeu roues directrices.
- Ruedas directrices.



- Slitte di appoggio.
- Skids.
- Satz Kufen.
- Jeu patins.
- Patines.

Mod.	mm	
	1046	554
TFB/Y 160	524	1076
	1046	754
TFB/Y 180	524	1276
	1216	784
TFB/Y 200	694	1306
	1326	874
TFB/Y 220	804	1396
	1560	940
TFB/Y 250	1040	1460



- Ruote frontali stabilizzatrici, regolabili in altezza.
- Front wheels kit.
- Regulierbare Stützräder für Frontanbau.
- Jeu roues frontales.
- Ruedas frontales estabilizadoras y regulables en altura.



- Albero cardanico.
- Pto drive shaft.
- Gelenkwelle.
- Arbre cardan.
- Cardan.

# TFB/YE



Trinciatrice da frutteto e vigneto per erba, sarmenti e materiale legnoso fino a Ø 8 cm., da applicare a trattori con potenza compresa tra 80 e 110 HP.



Mulcher for vineyard and orchard, suited to mulch grass, bushes, pruning and branches up to Ø 8 cm. for tractors from 80 to 110 HP.



Mulchgerät für Wein- und Obstbau, für Traktoren von 80 bis 110 PS. Es eignet sich zum Mulchen von Gras, Büsche und Äste bis Ø 8 cm.



Broyeur à vignobles et vergers indiqué pour broyer l'herbe, les buissons, les sarments et les tiges allant jusqu'à Ø 8 cm, pour tracteurs de 80 à 110 CV.



Trituradora para viñedos y frutales apta para triturar hierba, sarmientos y residuos de madera en general de hasta 8 cm. de diámetro para tractores con una potencia entre 80 y 110 CV.



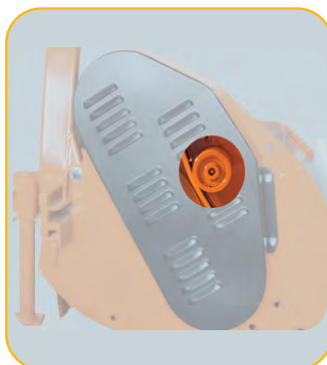





**HARDOX®**  
WEAR PLATE



- Attacco ai 3 punti spostabile a parallelogramma Cat. I-II.
- Displaceable three-point hitch Cat. I-II
- Versetzbarer Dreipunktbock Kat. I-II
- Attelage déportable à 3 points Cat. I-II
- Enganche a los 3 puntos desplazable Cat. I-II

- Tenditore automatico delle cinghie. Cat. I-II.
- Full automatic belts adjuster.
- Automatische Riemenspannung.
- Tendeur automatique des courroies.
- Tensor automático de las correas.

- Fiancata destra arrotondata.
- Chamfered profile on the right-end chassis' corner.
- Seitlich Abschrägung auf Mulcherrahmen.
- Coin côté droite arrondi.
- Perfil rebajado en la parte derecha.

Mod.	 cm	 HP		 mm	 n°	 n°	 n°	 PTO	 cm			 KG	
		Min	Max						A	B	C	min	max
TFB/YE 160	160	60	110	930 - 670 - 1730	14	42	4	540 (1000)	105	180	130	660	850
TFB/YE 180	180	60	110	930 - 1070 - 1930	16	48	4	540 (1000)	105	200	130	700	890
TFB/YE 200	200	80	110	930 - 1070 - 2130	18	54	4	540 (1000)	105	220	130	740	940
TFB/YE 220	220	80	110	930 - 1270 - 2330	20	60	4	540 (1000)	105	240	130	790	990

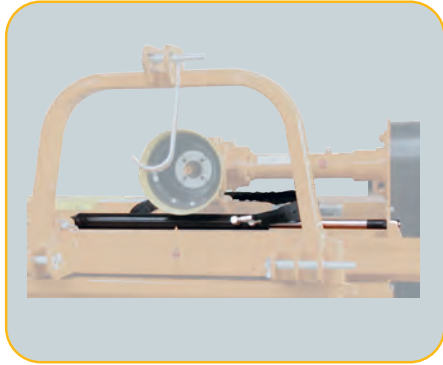

- Spostamento idraulico con tubi e innesti rapidi.
- Hydraulic side shift with hoses and quick couplings.
- Hydraulische Seitenverschiebung.
- Déport hydraulique avec tuyaux et prises rapides.
- Desplazamiento hidráulico.



- Albero cardanico 60/1400 N
- PTO drive shaft 60/1400 N.
- Gelenkwelle 60/1400 N.
- Arbre cardan 60/1400 N
- Cardan 60/1400 N.

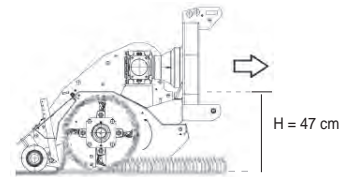

- Rullo livellatore regolabile con pulirullo e rastrelli raccoglitori.
- Adjustable and levelling roller, with scraper and rakes.
- Einstellbare Stützwalze mit Abstreifer und Sammelrechen.
- Rouleau palpeur réglable avec décrotoir et râeaux ramasseurs.
- Rodillo nivelador con rascador y rastrillos recogedores.

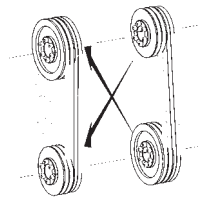

- PTO 540/1000 g/min (invertendo le pulegge).
- PTO 540/1000 rpm (reversing the pulleys).
- Getriebe 540 oder 1000 U/min (Umkehrbare Riemenscheibe).
- PDF 540/1000 t/min (en inversant les poulies).
- PTO 540/1000 g/min (invirtiendo las poleas).

## OPTIONALS



- Slitte di appoggio.
- Skids.
- Satz Kufen.
- Jeu patins.



- Rullo posteriore livellatore con diametro maggiorato.
- Rear leveling roller with big diameter.
- Heck- Stuetzwalze mit grossem Durchmesser.
- Rouleau niveleur arrière avec majeur diamètre.



- Protezioni frontali in catena e gomma.
- Front chains protectors and rubber.
- Frontschutze mit Ketten und Gummi.
- Protecciones frontales par chaînes et caoutchouc.
- Protecciones frontales en cadenas con goma.

# TFB/C



Trinciatrice da frutteto e vigneto per erba, sarmenti e materiale legnoso fino a Ø 8 cm., da applicare a trattori con potenza compresa tra 60 e 110 HP.



Mulcher for vineyard and orchard, suited to mulch grass, bushes, pruning and branches up to Ø 8 cm. for tractors from 60 to 110 HP.



Mulchgerät für Wein- und Obstbau, für Traktoren von 60 bis 110 PS. Es eignet sich zum Mulchen von Gras, Büsche und Äste bis Ø 8 cm.



Broyeur à vignobles et vergers indiqué pour broyer l'herbe, les buissons, les sarments et les tiges allant jusqu'à Ø 8 cm, pour tracteurs de 60 à 110 CV.



Trituradora para viñedos y frutales apta para triturar hierba, sarmientos y residuos de madera en general de hasta 8 cm. de diámetro para tractores con una potencia entre 60 y 110 CV.

**HARDOX®**  
WEAR PLATE



- Attacco ai 3 punti spostabile meccanicamente, Cat. I-II e tirante terzo punto.
- Displaceable 3 points linkage, Cat. I-II (mechanical) and top link tie-rod.
- Versetzbarer Dreipunktbock, Kat. I-II (mechanischer) und Oberlenk Zugstange.
- Attelage déportable à 3 points, Cat. I-II (mécanique) et tige de renfort au troisième point.
- Enganche a los 3 puntos desplazable Cat. I-II (desplazamiento mecánico) y tirante de refuerzo.

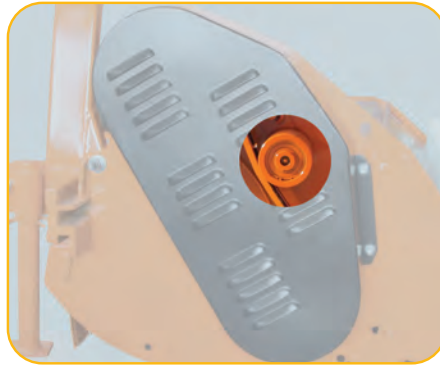

- Tenditore automatico delle cinghie.
- Full automatic belts adjuster.
- Automatische Riemenspannung.
- Tendeur automatique des courroies.
- Tensor automático de las correas.



- Fiancata destra arrotondata.
- Chamfered profile on the right-end chassis' corner.
- Seitlich Abschrägung auf Mulcherrahmen.
- Coin côté droite arrondi.
- Perfil rebajado en la parte derecha.

Mod.													
	cm	Min	Max	mm	n°	n°	n°	PTO	A	B	C	min	max
<b>TFB/C 140</b>	140	60	110	875   525	12	36	4	540 (1000)	100	160	130	650	810
				355   1045									
<b>TFB/C 160</b>	160	60	110	875   725	14	42	4	540 (1000)	100	180	130	700	880
				355   1245									
<b>TFB/C 180</b>	180	60	110	875   925	16	48	4	540 (1000)	100	200	130	740	930
				355   1455									
<b>TFB/C 200</b>	200	80	110	875   1125	18	54	4	540 (1000)	100	220	130	780	980
				355   1645									
<b>TFB/C 220</b>	220	80	110	1040   1160	20	60	4	540 (1000)	100	240	130	830	1030
				520   1680									
<b>TFB/C 250</b>	250	80	110	1040   1460	22	66	5	540 (1000)	100	270	130	930	1150
				520   1980									

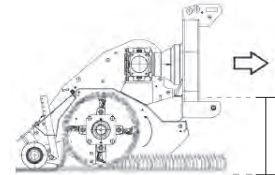
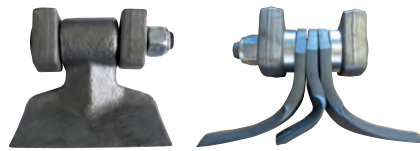
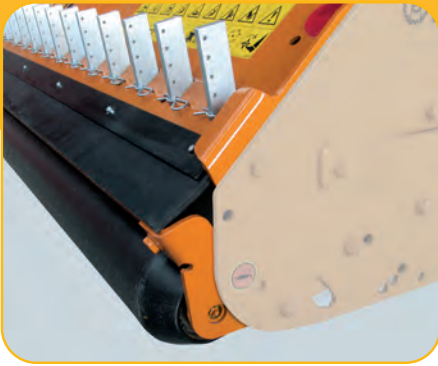

H = 47 cm (140-220)  
H = 49 cm (250)

- Rullo livellatore regolabile con pulirullo e rastrelli raccoglitori.
- Adjustable and levelling roller, with scraper and rakes.
- Einstellbare Stützwalze mit Abstreifer und Sammelrechen.
- Rouleau palpeur réglable avec décrottoir et râteaux ramasseurs.
- Rodillo nivelador con rascador y rastrillos recogedores.

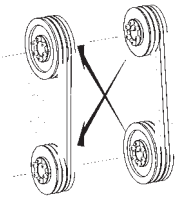

- PTO 540/1000 g/min (invertendo le pulegge).
- PTO 540/1000 rpm (reversing the pulleys).
- Getriebe 540 oder 1000 U/min (Umkehrbare Riemenscheibe).
- PDF 540/1000 t/min (en inversant les poulies).
- PTO 540/1000 g/min (invirtiendo las poleas).

## OPTIONALS



- Spostamento idraulico con tubi e innesti rapidi.
- Hydraulic side shift with hoses and quick couplings.
- Hydraulische Seitenverschiebung.
- Déport hydraulique avec tuyaux et prises rapides.
- Desplazamiento hidráulico.



- Rullo posteriore livellatore con diametro maggiorato.
- Rear leveling roller with big diameter.
- Heck- Stuetzwalze mit grossem Durchmesser.
- Rouleau niveleur arrière avec majeur diamètre.
- Rodillo nivelador trasero de mayor diámetro.



- Attacco centrale.
- Centre mounted linkage.
- Mittiger Anbau.
- Attelage axial.
- Enganche central.



- Ruote frontali stabilizzatrici, regolabili in altezza.
- Front wheels kit.
- Regulierbare Stützräder für Frontanbau.
- Jeu roues frontales.
- Ruedas frontales estabilizadoras y regulables en altura.



- Slitte di appoggio.
- Skids.
- Satz Kufen.
- Jeu patins.
- Patines.

Mod.	mm	
<b>TFB/C 160</b>	1046   554	
	524   1076	
<b>TFB/C 180</b>	1046   754	
	524   1276	
<b>TFB/C 200</b>	1216   784	
	694   1306	
<b>TFB/C 220</b>	1326   874	
	804   1396	
<b>TFB/C 250</b>	1560   940	
	1040   1460	

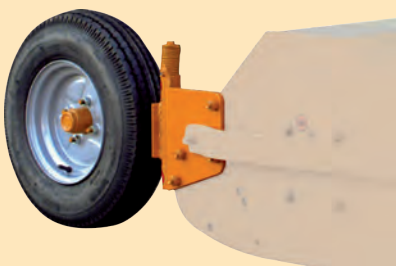

- Kit ruote sterzanti.
- Steering wheels.
- Satz Hinterlenkräder.
- Jeu roues directrices.
- Ruedas directrices.



- Albero cardanico.
- Pto drive shaft.
- Gelenkwelle.
- Arbre cardan.
- Cardan.

# TFB/REV

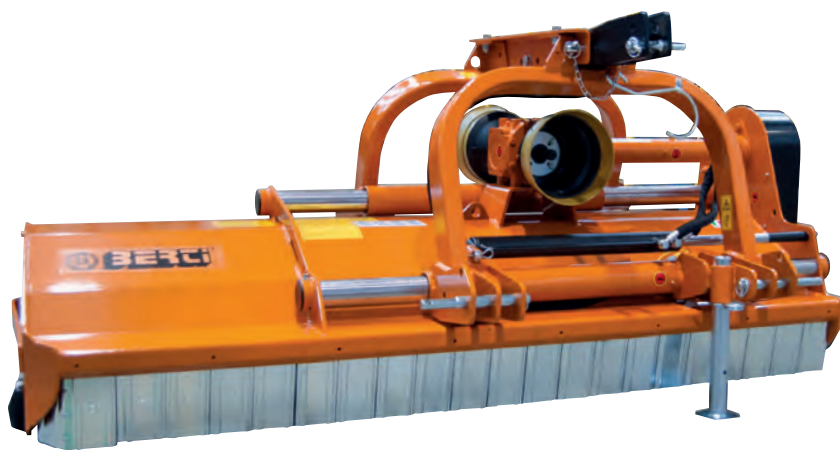

**HARDOX®**  
WEAR PLATE



Trinciatrice compatta applicabile su sollevatore anteriore o posteriore del trattore (anche a guida retroversa), con potenze comprese tra 60 e 110 HP. Consigliata per vigneti e frutteti per la trinciatura di erba, sarmenti, ramaglia fino a Ø 8 cm.



Front and rear compact mulcher to fit tractors from 60 to 110 HP. Suited to mulch grass, bushes, pruning and branches up to Ø 8 cm., on vineyards and orchards.



Heck- und Frontanbau Mulchgerät für den Wein- und Obstbau, für Traktoren von 60 bis 110 PS. Es eignet sich zum Mulchen von Gras, Büsche und Äste bis Ø 8 cm.



Broyeur réversible pour tracteurs de 60 à 110 CV. Indiqué pour broyer l'herbe, les buissons, les sarments et les tiges allant jusqu'à Ø 8 cm. dans les vignobles ou les vergers.



Trituradora para tractores reversibles con una potencia entre 60 y 110 CV. Apta para viñedos y frutales, para triturar hierba, sarmientos y ramaje en general de hasta 8 cm. de diámetro.



- Doppio attacco ai 3 punti spostabile meccanicamente e reversibile, Cat. I-II.
- Displaceable and reversible double 3 points linkage Cat. I-II (mechanical).
- Doppelter versetzbarer und umkehrbarer Dreipunktbock, Kat. I-II (mechanischer).
- Double attelage déportable et réversible à 3 points, Cat. I-II (mécanique).
- Doble enganche a los 3 puntos desplazable y reversible Cat. I-II (desplazamiento mecánico).



- Tenditore automatico delle cinghie.
- Full automatic belts adjuster.
- Automatische Riemenspannung.
- Tendeur automatique des courroies.
- Tensor automático de las correas.



- Fiancata destra arrotondata.
- Chamfered profile on the right-end chassis' corner.
- Seitlich Abschrägung auf Mulcherrahmen.
- Coin côté droite arrondi.
- Perfil rebajado en la parte derecha.

Mod.													
	cm	Min	Max	mm	n°	n°	n°	PTO	A	B	C	min	max
TFB/REV 140	140	60	110	875   525	12	36	4	540 (1000)	110	160	125	710	830
				355   1045									
TFB/REV 160	160	60	110	875   725	14	42	4	540 (1000)	110	180	125	750	890
				355   1245									
TFB/REV 180	180	60	110	875   925	16	48	4	540 (1000)	110	200	125	800	950
				355   1455									
TFB/REV 200	200	80	110	875   1125	18	54	4	540 (1000)	110	220	125	840	1000
				355   1645									
TFB/REV 220	220	80	110	1040   1160	20	60	4	540 (1000)	110	240	125	890	1050
				520   1680									



- Slitte di appoggio.
- Skids.
- Satz Kufen.
- Jeu patins.
- Patines.



- Rullo livellatore regolabile con pulirullo e rastrelli raccoglitori.
- Adjustable and levelling roller, with scraper and rakes.
- Einstellbare Stützwalze mit Abstreifer und Sammelrechen.
- Rouleau palpeur réglable avec décrotoir et râteaux ramasseurs.
- Rodillo nivelador con rascador y rastrillos recogedores.

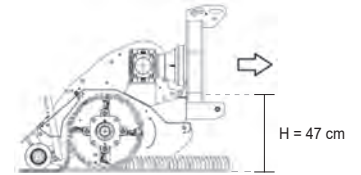

- Doppia ruota libera nella scatola ingranaggi\*.
- Double free wheel in the gearbox\*.
- Doppelten Freilauf im Getriebe\*.
- Double roue libre dans le boîtier\*.
- Doble rueda libre en la caja de transmisión\*.

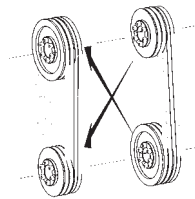
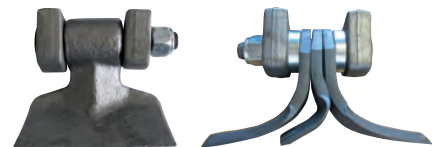
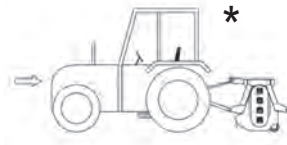

- PTO 540/1000 g/min (invertendo le pulegge).
- PTO 540/1000 rpm (reversing the pulleys).
- Getriebe 540 oder 1000 U/min (Umkehrbare Riemenscheibe).
- PDF 540/1000 t/min (en inversant les poulies).
- PTO 540/1000 g/min (invirtiendo las poleas).

## OPTIONALS



- Spostamento idraulico con tubi e innesti rapidi.
- Hydraulic side shift with hoses and quick couplings.
- Hydraulische Seitenverschiebung.
- Déport hydraulique avec tuyaux et prises rapides.
- Desplazamiento hidráulico.



- Rullo posteriore livellatore con diametro maggiorato.
- Rear leveling roller with big diameter.
- Heck- Stuetzwalze mit grossem Durchmesser.
- Rouleau niveleur arrière avec majeur diamètre.
- Rodillo nivelador trasero de mayor diámetro.



- Attacco centrale.
- Centre mounted linkage.
- Mittiger Anbau.
- Attelage axial.
- Enganche central.



- Albero cardanico.
- Pto drive shaft.
- Gelenkwelle.
- Arbre cardan.
- Cardan.

Mod.	mm	
TFB/REV 160	1025	575
	505	1095
TFB/REV 180	1025	775
	505	1295
TFB/REV 200	1195	805
	675	1325
TFB/REV 220	1305	895
	785	1415

# TFB/M



**STRENX®**  
PERFORMANCE STEEL

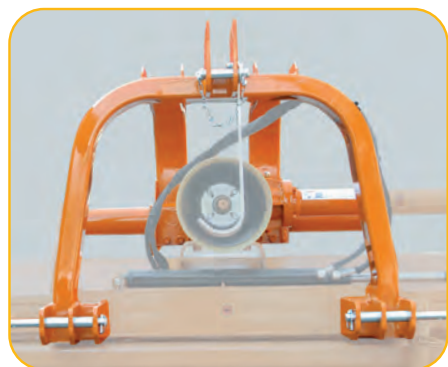

- Attacco ai 3 punti spostabile meccanicamente, Cat. II e tirante terzo punto.
- Displaceable three points linkage, Cat. II (mechanical) and top link tie-rod.
- Versetzbarer Dreipunktbock, Kat. II (mechanischer) und Oberlenk Zugstange.
- Attelage déportable à 3 points, Cat. II (mécanique) et tige de renfort au troisième point.
- Enganche a los 3 puntos desplazable Cat. II (desplazamiento mecánico) y tirante de refuerzo.



- Tenditore automatico delle cinghie.
- Full automatic belts adjuster.
- Automatische Riemenspannung.
- Tendeur automatique des courroies.
- Tensor automático de las correas.



Trinciatrice rinforzata per vigneto, frutteto e sottobosco consigliata per erba cespugli sarmenti e materiale legnoso fino a Ø 10-12 cm., da applicare a trattori con potenze comprese tra 70 e 150 HP.



Heavy duty mulcher for orchard and under-wood, suited to mulch grass, bushes, pruning and branches up to Ø 10-12 cm. for tractors from 70 to 150 HP.



Verstärkte Mulchgerät für den Wein- und Obstbau, für Traktoren von 70 bis 150 PS. Es eignet sich zum Mulchen von Gebüsch und Sträuchern und Äste bis Ø 10-12 cm.



Broyeur renforcé pour vergers et sous-bois indiqué pour broyer l'herbe, les buissons, les sarments et les tiges allant jusqu'à Ø 10-12 cm., pour tracteurs de 70 à 150 CV.



Trituradora reforzada para la trituración desde hierba hasta restos leñosos (hasta 10-12 cm. Ø) en viñedos, y otras explotaciones agrícolas. Para tractores desde 70 hasta 150 CV.

Mod.												
	cm	Min	Max	mm	n°	n°	PTO	A	B	C	min	max
<b>TFB/M 180</b>	180	70	110	956 844 434 1366 1046 954	16	5	540 (1000)	115	200	140	875	995
<b>TFB/M 200</b>	200	70	110	524 1476 1046 954	18	5	540 (1000)	115	220	140	925	1050
<b>TFB/M 200 Special</b>	200	80	150	524 1476 1046 1154	18	5	540 (1000)	120	220	140	990	1125
<b>TFB/M 220</b>	220	80	150	524 1676 1046 1454	20	5	540 (1000)	120	240	140	1050	1195
<b>TFB/M 250</b>	250	100	150	524 1976 1046 1754	22	5	1000 (540)	120	270	140	1125	1280
<b>TFB/M 280</b>	280	100	150	524 2276 1046 1954	26	5	1000 (540)	120	300	140	1195	1365
<b>TFB/M 300</b>	300	100	150	524 2476	28	5	1000 (540)	120	320	140	1235	1415

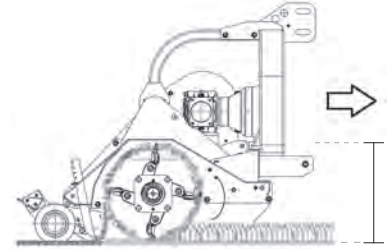

H = 50 cm (180-200)  
H = 54 cm (200S-300)

- Rullo livellatore regolabile con pulirullo e rastrelli raccoglitori.
- Adjustable and levelling roller, with scraper and rakes.
- Einstellbare Stützwalze mit Abstreifer und Sammelrechen.
- Rouleau palpeur réglable avec décrotoir et râtaux ramasseurs.
- Rodillo nivelador con rascador y rastrillos recogedores.

## OPTIONALS

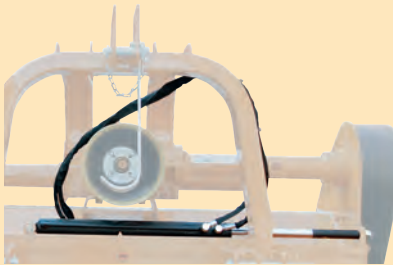

- Spostamento idraulico con tubi e innesti rapidi.
- Hydraulic side shift with hoses and quick couplings.
- Hydraulische Seitenverschiebung.
- Déport hydraulique avec tuyaux et prises rapides.
- Desplazamiento hidráulico.



- Slitte di appoggio.
- Skids.
- Satz Kufen.
- Jeu patins.
- Patines.



- Attacco centrale.
- Centre mounted linkage.
- Mittiger Anbau.
- Attelage axial.
- Enganche central.



- Ruote anteriori stabilizzatrici, regolabili in altezza.
- Height adjustable front wheels.
- Regulierbare Stützräder für Frontanbau.
- Roues frontales réglables en hauteur.
- Ruedas frontales estabilizadoras y regulables en altura.



- Albero cardanico.
- Pto drive shaft.
- Gelenkwelle.
- Arbre cardan.
- Cardan.

Mod.	mm	
	1616	1184
<b>TFB/M 280</b>	1094	1706
<b>TFB/M 300</b>	1616	1384
	1094	1906

# TFB/ME



**STRENX®**  
PERFORMANCE STEEL



Trinciatrice rinforzata per vigneto, frutteto e sottobosco consigliata per erba cespugli sarmenti e materiale legnoso fino a Ø 12 cm., da applicare a trattori con potenze comprese tra 80 e 180 HP.



Heavy duty mulcher for orchard and under-wood, suited to mulch grass, bushes, pruning and branches up to Ø 12 cm. for tractors from 80 to 180 HP.



Verstärkte Mulchgerät für den Wein- und Obstbau, für Traktoren von 80 bis 180 PS. Es eignet sich zum Mulchen von Gebüsch und Sträuchern und Äste bis Ø 12 cm.



Broyeur renforcé pour vergers et sous-bois indiqué pour broyer l'herbe, les buissons, les sarments et les tiges allant jusqu'à Ø 12 cm., pour tracteurs de 80 à 180 CV.



Trituradora reforzada para la trituración desde hierba hasta restos leñosos (hasta 12 cm. Ø) en viñedos, y otras explotaciones agrícolas. Para tractores desde 80 hasta 180 CV.













- Attacco ai 3 punti con doppia posizione di aggancio spostabile idraulicamente, Cat. II.
- Displaceable three-point hitch Cat. II, with two coupling positions (hydraulic).
- Versetzbarer Dreipunktbock Kat. II, mit zwei Kupplungspositionen möglich (hydraulischer).
- Attelage déportable à 3 points Cat. II, avec deux positions possibles (hydraulique).
- Enganche a los 3 puntos desplazable Cat. II (desplazamiento hidráulico) con dos posiciones de acoplamiento posibles.



- Tenditore automatico delle cinghie.
- Full automatic belts adjuster.
- Automatische Riemenspannung.
- Tendeur automatique des courroies.
- Tensor automático de las correas.



- Rullo livellatore regolabile con pulirullo.
- Adjustable and levelling roller with scraper.
- Einstellbare Stützwalze mit Abstreifer.
- Rouleau palpeur réglable avec décrotoir.
- Rodillo nivelador con rascador.

Mod.															
		cm	Min	Max	mm	mm	n°				n°	PTO	A		
<b>TFB/ME 200</b>	200	80	180	700 0	1300 2300	1000 0	1000 2000	18	5	540 (1000)	115	230	147	1110	1190
<b>TFB/ME 220</b>	220	80	180	700 0	1500 2500	1000 0	1200 2200	20	5	540 (1000)	115	250	147	1190	1280
<b>TFB/ME 250</b>	250	80	180	700 0	1800 2800	1000 0	1500 2500	22	5	540 (1000)	115	280	147	1280	1370



- Protezioni frontali in catena e gomma.
- Front chains protectors and rubber.
- Frontschutze mit Ketten und Gummi.
- Protections frontales par chaînes et caoutchouc.
- Protecciones frontales en cadenas con goma.



- Albero cardanico rinforzato.
- Hardened PTO drive shaft.
- Verstärkte Gelenkwelle.
- Arbre cardan à profil renforcé.
- Cardan reforzado.

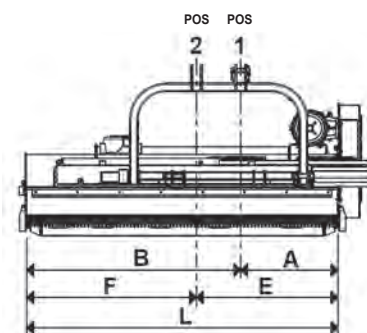
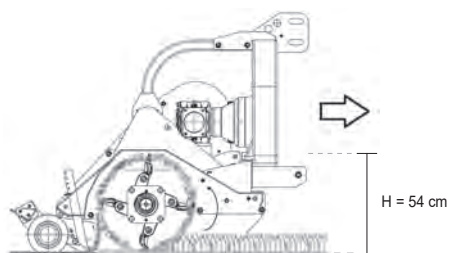
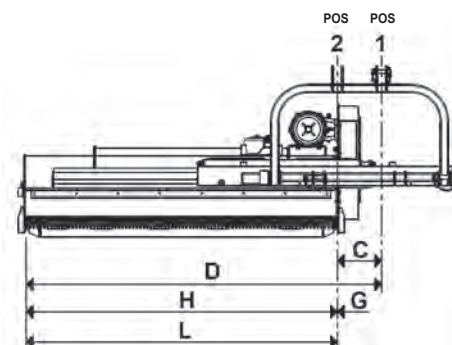

Mod.	POS. 1 (mm)					POS. 2 (mm)			
	L	A	B	C	D	E	F	G	H
<b>TFB/ME 200</b>	200	700	1300	300	2300	1000	1000	0	2000
<b>TFB/ME 220</b>	220	700	1500	300	2500	1000	1200	0	2200
<b>TFB/ME 250</b>	250	700	1800	300	2800	1000	1500	0	2500

## OPTIONALS



- Slitte di appoggio.
- Skids.
- Satz Kufen.
- Jeu patins.
- Patines.



- Rastrelli raccoglitori.
- Rakes.
- Sammelrechen.
- Râteaux ramasseurs.
- Rastrillos recogedores.



- Kit segnaletica stradale con luci.
- Set road-warning panels with lights.
- Satz Warntafel mit Beleuchtung.
- Kit de signalisation avec système d'éclairage.
- Kit de señalización de carretera con luces.



# bertima.it



TFB/L



TFB/LR



ZETA

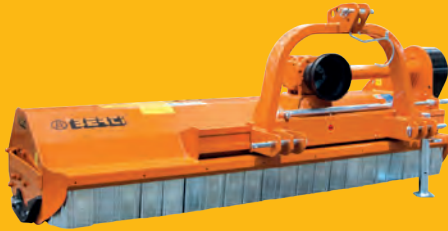

TFB/Y



TFB/YE



TFB/C



TFB/REV



TFB/M



TFB/ME

Le illustrazioni e i dati del presente catalogo sono indicative e non vincolanti per il costruttore • All pictures and data above are indicative only and not binding for the manufacturer • Alle in diesem Katalog enthaltenen Angaben und Zeichnungen sind annähernd und unverbindlich • Toutes les données insérées dans ce catalogue ont été indiquées seulement à titre de renseignement • Las fotografías y los datos mostrados son meramente indicativos y podrían ser variados sin previo aviso por el fabricante.



**BERTI**  
MACCHINE AGRICOLE



Via Musi, 1/A-3-4 - 37042 Caldiero (VR) ITALY  
Tel. +39.045.6139711 - Fax +39.045.6150251  
info@bertima.it



 **MADE IN ITALY**