

CONVEYORS

CONVEY-ALL™



DURABLE. FUNCTIONAL. **RELIABLE.**

CONVEY-ALL™

DURABLE.

At Convey-All™, we use heavy-duty components, quality materials and precision manufacturing techniques. When you need a product that is durable, rugged and can be depended on, choose Convey-All™.



FUNCTIONAL.

Our no-nonsense, straight forward designs make our products simple and operator friendly, assuring versatility, convenience and functionality.



RELIABLE.

With over 35 years experience, Convey-All™ understands the needs and expectations of our customers. We are committed to developing the most usable, innovative and quality products with service excellence for our customers.



SIGNATURE HYDRAULIC DESIGN

Convey-All™, products are designed and built with the customer in mind. Usability, functionality and serviceability are at the core of every Convey-All™ Conveyor.

By utilizing hydraulic power, we mount the engine and fuel tank on the axle for easy access and service. With the engine mounted on the axle, we also achieve a low center of gravity, making the conveyor easy to tow at highway speed.

Another key advantage of our hydraulic drive is the elimination of belts and pulleys as well as chains and sprockets, thus avoiding slippage, wearing parts and service points. Fewer moving parts also provide a safer operation.



HYDRAULIC DRIVE | CLEAN DESIGN WITH MINIMAL MAINTENANCE. THERE ARE NO BELTS, PULLEYS, CHAINS, COUNTER SHAFTS, OR BEARINGS TO SERVICE

MAXIMUM PERFORMANCE DRIVE BOXES

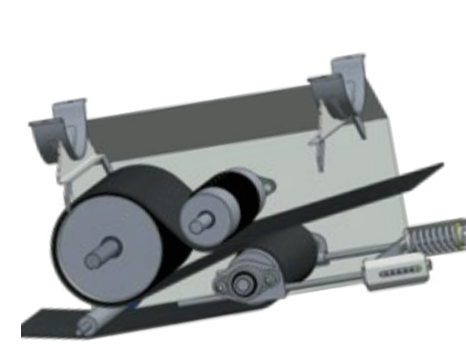

SPRING TENSION DRIVE BOX

Used on conveyors 52.5' and shorter. This Drive Box has a large 10" Drive Roller. The 5" pinch roller ensures more belt-to-drive roller contact, virtually eliminating belt slippage. Spring tension control and constant pressure ensure less adjusting.



POSITIVE PINCH DRIVE BOX

Used on conveyors 55' and longer. This Drive Box features the Sliding Pinch Roller. It maintains positive pressure on the Drive Roller. As more product is loaded, the Pinch Roller automatically increases its pressure on the Drive Roller.

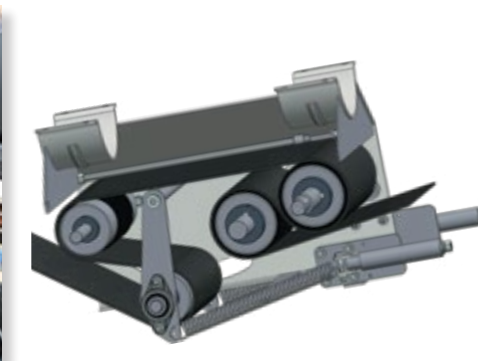

BIN FILL CONVEYORS

BIN FILL CONVEYORS



LEAVE THE TRACTOR IN THE SHED WITH
**CONVEY-ALL'S SELF-PROPELLED, SELF
 CONTAINED BIN FILL CONVEYORS**
 1690 WITH SWING OUT PICTURED



22100

1690-SP WITH SWING OUT

1690-SP WITH SWING OUT & STAINLESS PACKAGE

10" Tube
 16" Belt

UP TO
9,000BPH

14" Tube
 22" Belt

UP TO
12,000BPH

16" BELT CONVEYORS

Model	Under Carriage	Mover Kit	Swing Out	Axle Width	Transport Height	Transport Length	- 15° -		- 20° -		- 25° -		- 30° -	
							Discharge Height	Length	Discharge Height	Length	Discharge Height	Length	Discharge Height	Length
1655	Scissor Lift	N/A	N/A	11' 4"	12' 6"	60' 8"	13' 5"	5' 2"	18' 4"	54'	23' 2"	52' 5"	27' 9"	50' 6"
1670	Scissor Lift	AVAIL	AVAIL	11' 4"	11' 10"	75' 11"	17' 4"	69' 8"	23' 6"	68' 1"	29' 6"	66' 1"	35' 3"	63' 6"
1675	Scissor Lift	AVAIL	AVAIL	11' 4"	12' 5"	80' 11"	18' 7"	74' 6"	25' 2"	72' 10"	31' 7"	70' 7"	37' 9"	67' 10"
1685	Scissor Lift	AVAIL	AVAIL	12' 6"	11' 7"	91' 1"	21' 2"	84' 2"	28' 7"	82' 3"	35' 10"	79' 8"	42' 9"	76' 6"
1690	Scissor Lift	AVAIL	AVAIL	12' 6"	12' 2"	96'	22' 6"	89'	30' 4"	86' 11"	37' 11"	84' 2"	45' 3"	80' 10"
16100	Scissor Lift	N/A	AVAIL	13' 6"	14' 7"	105' 10"	25' 1"	98' 8"	33' 9"	96' 4"	42' 2"	93' 3"	50' 3"	89' 6"

22" BELT CONVEYORS

Model	Under Carriage	Mover Kit	Swing Out	Axle Width	Transport Height	Transport Length	- 15° -		- 20° -		- 25° -		- 30° -	
							Discharge Height	Length	Discharge Height	Length	Discharge Height	Length	Discharge Height	Length
2265	Scissor Lift	N/A	N/A	9' 1"	11' 5"	69'	15' 6"	63'	21' 1"	61' 8"	26' 5"	59' 10"	31' 7"	57' 7"
2270	Scissor Lift	N/A	N/A	9' 1"	11' 7"	74'	16' 10"	67' 10"	22' 9"	66' 4"	28' 6"	64' 4"	34' 1"	61' 11"
2275	Scissor Lift	N/A	N/A	9' 1"	11' 2"	78' 11"	18' 1"	72' 8"	24' 6"	71' 1"	30' 8"	68' 11"	36' 7"	66' 3"
2285	Scissor Lift	N/A	AVAIL	13' 6"	12' 4"	89'	20' 9"	82' 4"	28'	80' 5"	35'	77' 11"	41' 9"	74' 10"
2290	Scissor Lift	N/A	AVAIL	13' 6"	13' 1"	93' 11"	22' 7"	87' 2"	30' 1"	85' 2"	37' 5"	82' 5"	44' 6"	79' 2"
22100	Scissor Lift	N/A	AVAIL	13' 6"	14'	103' 11"	25'	96' 10"	33' 6"	94' 6"	41' 8"	91' 6"	49' 6"	87' 10"
22110	Scissor Lift	N/A	AVAIL	13' 6"	14' 6"	108' 11"	26' 5"	101' 8"	35' 3"	99' 3"	43' 9"	96'	52'	92' 2"
22120	Scissor Lift	N/A	AVAIL	13' 11"	15'	124'	29' 10"	116' 2"	40'	113' 4"	49' 10"	109' 8"	59' 4"	105' 2"

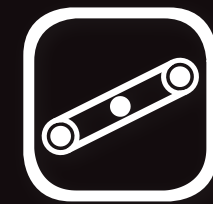

Convey-All™ has a complete range of tube conveyor lengths. A size for any job. Our easy moving, long reaching tube conveyors are great for filling bins or making large piles.

Convey-All™ conveyors are designed to be efficient and simple to use. The engine and control station are set low for easy access. The undercarriages are rugged and heavy duty, using structural steel and fabricated for bolt-together durability. Combine our Bin Fill Conveyors with a Convey-All™ Transfer Conveyor or Swing Out for ultimate efficiency.

STANDARD FEATURES:

- Collapsible hopper
- Full length windguards
- Heavy-duty scissor lift undercarriages
- Positive Pinch Drive Box

SWING OUT (SO) PACKAGE:

- 360 degree swing allows the user to unload on either side of conveyor (no tractor in the way at end of conveyor)
- Remote controlled swing can be placed into unload position with the push of a button
- Long reach for maximum accessibility

MOVER KIT (SP) PACKAGE:

Our mover package takes convenience to a new level. Users can easily move large conveyors without hooking up to or tying up a tractor.

OPTIONAL FEATURES:

- Side or end PTO, gas, diesel, electric or hydraulic drive
- Stainless steel components
- Hopper lift (on longer 22" conveyors)
- Winch for collapsible hopper
- Hydraulic lift

TRUCK LOAD CONVEYORS



OUR FULLY LOADED **TRUCK LOAD (TL)** MODELS ARE **SELF-PROPELLED, SELF CONTAINED & FULLY HYDRAULIC.**
 ————— 1645-TL PICTURED —————

TRUCK LOAD CONVEYORS



10" Tube
12" Belt

UP TO
3,500BPH

10" Tube
16" Belt

UP TO
9,000BPH

14" Tube
22" Belt

UP TO
12,000BPH

12" BELT CONVEYORS

Model	Under Carriage	Axle Width	Transport Height	Transport Length	- 15° -		- 20° -		- 25° -		- 30° -	
					Discharge Height	Length	Discharge Height	Length	Discharge Height	Length	Discharge Height	Length
1235-TED	A-Frame	7' 11"	11' 9"	37' 2"	n/a	n/a	11' 1"	33' 10"	14'	32' 11"	16' 10"	31' 10"
1240-TED	A-Frame	7' 11"	13' 10"	41' 9"	n/a	n/a	13' 11"	38' 7"	17' 11"	37' 6"	21' 2"	35' 11"
1235-FL	A-Frame	7' 11"	8' 2"	39' 10"	n/a	n/a	10' 3"	33' 11"	13' 5"	33'	16' 6"	31' 10"
1245-FL	A-Frame	8'	14' 2"	42' 3"	n/a	n/a	n/a	n/a	18'	42' 3"	21' 10"	40' 8"
1245	A-Frame	9' 2"	11' 2"	49' 2"	11' 5"	44' 7"	15' 5"	43' 7"	19' 3"	42' 4"	23'	40' 8"

TED = Top End Drive. FL = Field Loader. TL = Transloader (Truck loader)

16" BELT CONVEYORS

Model	Under Carriage	Axle Width	Transport Height	Transport Length	- 15° -		- 20° -		- 25° -		- 30° -	
					Discharge Height	Length	Discharge Height	Length	Discharge Height	Length	Discharge Height	Length
1640-TL	A-Frame	8' 4"	9' 7"	43' 9"	n/a	n/a	10' 7"	40' 9"	14'	39' 10"	17' 4"	38' 4"
1650-TL	A-Frame	8' 4"	11' 5"	53' 7"	n/a	n/a	14' 5"	46'	18' 8"	44' 8"	22' 10"	43'
1658-TL	A-Frame	8' 4"	12' 10"	60' 8"	n/a	n/a	17'	53'	21' 10"	51' 6"	26' 7"	49' 6"
1675-TL	Scissor Lift	11' 7"	13' 1"	84' 4"	n/a	n/a	24' 5"	74' 9"	31' 1"	72' 5"	37' 6"	69' 6"
1645	A-Frame	9' 1"	11' 8"	50' 10"	10' 10"	45' 6"	14' 11"	44' 7"	18' 11"	43' 5"	22' 9"	41' 10"
1635-FL	A-Frame	7' 11"	10' 5"	43' 7"	n/a	n/a	10' 5"	30' 7"	13' 3"	29' 10"	15' 11"	28' 10"
1635	A-Frame	8'	10' 11"	40' 8"	n/a	n/a	12'	37' 1"	15' 1"	35' 10"	18' 1"	34' 5"
1645	A-Frame	9' 1"	11' 8"	50' 10"	10' 10"	45' 6"	14' 11"	44' 7"	18' 11"	43' 5"	22' 9"	41' 10"

22" BELT CONVEYORS

Model	Under Carriage	Axle Width	Transport Height	Transport Length	- 15° -		- 20° -		- 25° -		- 30° -	
					Discharge Height	Length	Discharge Height	Length	Discharge Height	Length	Discharge Height	Length
2245-TL	Scissor Lift	8' 4"	13' 6"	51' 6"	n/a	n/a	12' 2"	49' 1"	16' 3"	47' 9"	19' 9"	46' 3"
2252.5-TL	Scissor Lift	8' 4"	15' 4"	58' 10"	n/a	n/a	15' 9"	58' 7"	20' 7"	56' 11"	24' 6"	55' 2"
2235	A-Frame	8' 4"	10' 8"	38' 8"	n/a	n/a	10' 11"	33' 6"	13' 11"	32' 8"	16' 9"	31' 7"
2245	A-Frame	9' 1"	11' 3"	48' 9"	10' 5"	43' 8"	14' 3"	42' 10"	18' 1"	41' 8"	21' 9"	40' 2"

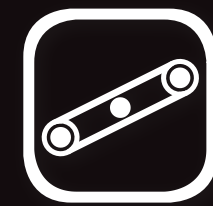

Our series of Truck Load conveyors are perfect for moving product from a bin, and loading into a truck or trailer.

Our fully loaded Truck Load (TL) models are self-propelled, meaning the conveyor can drive to the truck, not truck to conveyor. Being self-contained and fully hydraulic, means no dealing with belts, pulleys, chains or sprockets.

STANDARD FEATURES:

- Collapsible hopper
- Full length windguards
- Heavy-duty undercarriages
- Hydraulic lift
- Positive Pinch Drive Box (22" conveyors)
- Spring Tension Drive Box (16" conveyors)

FIELD LOADER (FL) PACKAGE:

- Stainless steel components
- Cold weather pkg (35hp gas engine)
- Heavy-duty, Railcar Hopper

TRUCK LOAD (TL) PACKAGE:

- Self-contained drive system
- Heavy duty mover kit
- Steering wheel(s) with hydraulic hopper lift
- Hydraulic valves and controls on tow vehicle's driver side
- Steel fuel tank, hydraulic oil reservoir
- Highway tires
- Discharge hood with electric actuator

TRUCK LOAD (TL) OPTIONS:

- Diesel engine (22" conveyors)
- Stainless steel components
- Cold weather pkg (16" conveyors)
- Hydraulic oil reservoir heater
- Fender and light package
- 2-5/16" ball receiver hitch
- Quad-adjust hood package
- Heavy-duty, Railcar Hopper

TRANSFER CONVEYORS

TRANSFER CONVEYORS



1615 Transfer

1616-RC Railcar

2228-DO Drive-Over

Model	Discharge Height to Ground	Hopper to Ground	Overall Length	Hopper Length
1214-GN	36" - 48"	61/2"	15' 4"	4' 9"
1615	38" - 48"	61/2" - 73/4"	17' 4"	5' 10"
1616-RC	36" - 48"	45/8"	20'	7'
2218	38" - 48"	61/2" - 73/4"	20' 2"	5' 10"
2218-RC	36" - 48"	45/8"	21' 6"	7'
2228-DO	3' 2"	8"	29'	9' 6"

TRANSFER CONVEYOR:

- Well balanced, easy to manoeuvre and position
- Longer hopper for superior containment, better reach

DRIVE-OVER CONVEYOR:

- 22" rubber belt inside a 14" tube
- 7" high deck for easy driving over
- Extra large 12' long deck, to easily position truck and trailer
- Containment flaps lay flat to drive over, raise to hold product
- Optional mover kit

RAILCAR CONVEYOR:

- Well balanced, easy to manoeuvre and position
- Extra low profile to easily fit under railcars
- Tow package (highway tires and hitch)
- Fold-up containment flaps to keep product on belt
- Optional transition with hold-down wheels
- Optional stainless steel

OPTION FOR ALL THREE CONVEYORS:

- Electric, gas or hydraulic drive

UNDERBIN CONVEYORS

UNDERBIN CONVEYORS

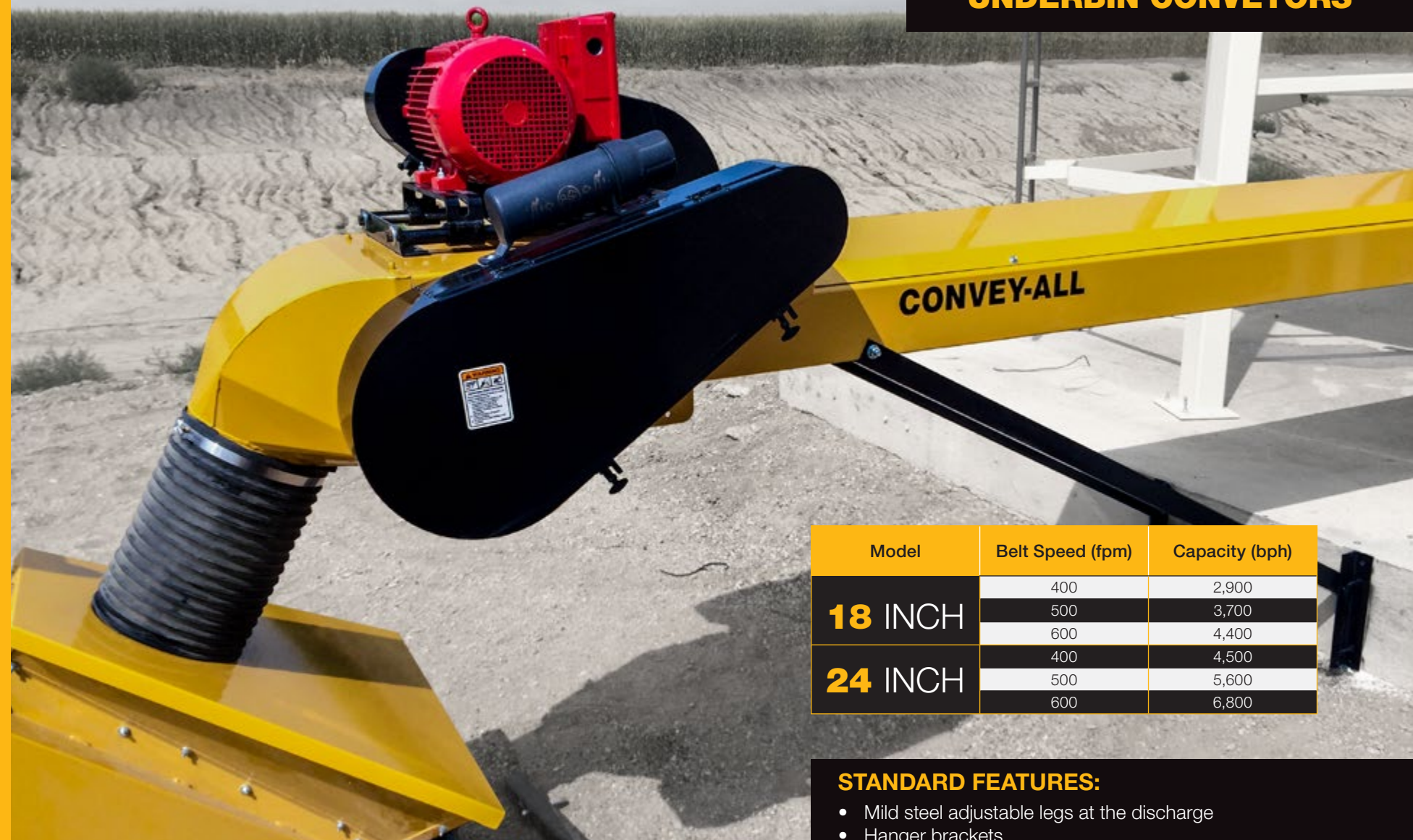

Model	Belt Speed (fpm)	Capacity (bph)
18 INCH	400	2,900
	500	3,700
	600	4,400
24 INCH	400	4,500
	500	5,600
	600	6,800

STANDARD FEATURES:

- Mild steel adjustable legs at the discharge
- Hanger brackets
- Adjustable legs at discharge
- Removable discharge hood
- Adjustable belt tension
- Electric drive (pulleys, belts, guards and mounts)
- Bed rollers spaced every 24"

OPTIONAL FEATURES:

- Air gates
- Weather covers
- Stainless steel components
- Receiving hoppers

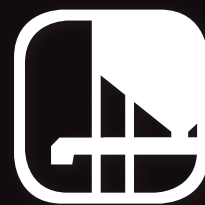

Convey-All™ has been providing conveyors to the ag industry since 1983, giving us over 35 years of experience in seed handling equipment. We take pride in building quality machinery with proven, straight-forward designs.

Our underbin conveyors are built in sections and are scalable to any site design, including easy expansion with your future growth.

PADDLE BELT CONVEYORS

PADDLE BELT CONVEYORS



TCP Model #	Axle Width	Transport Height	Transport Length	30°		35°		40°	
				Discharge Height	Length	Discharge Height	Length	Discharge Height	Length
1620	6' 9"	6' 10"	24' 4"	8' 9"	18' 2"	10' 3"	17' 6"	11' 8"	16' 8"
1625	8' 5"	9' 11"	28' 9"	11' 3"	22' 6"	13' 1"	21' 7"	14' 11"	20' 6"
1630	8' 5"	11' 9"	33' 4"	13' 9"	26' 10"	16' 0"	25' 8"	18' 1"	24' 3"
1635	8' 5"	12' 8"	38' 4"	16' 3"	31' 2"	18' 10"	29' 9"	21' 4"	28' 2"
1640	8' 5"	12' 9"	43' 7"	18' 9"	35' 6"	21' 9"	33' 10"	24' 6"	32' 0"
1645	8' 5"	13' 4"	48' 7"	21' 3"	39' 10"	24' 7"	38' 10"	27' 9"	35' 9"



Convey-All™ Paddle Belt Conveyors greatly increase the angle of operation, up to 40 degrees, while matching the capacity of your seed treater. The belt design is gentle on your seed. Excellent hopper clean-out access and enclosed belt return ensures long belt life. The conveyor is available in either a transport and stationary configuration.

STANDARD FEATURES:

- A-frame undercarriage
- Top-end electric drive
- 10" tube diameter
- 16" wide paddle belt
- Hopper access panel

OPTIONAL FEATURES:

- Steel hopper cover
- Collapsible hopper



WE'VE PUT OVER **2 MILLION BUSHELS** THROUGH OUR **CONVEY-ALL™ 1690-SO & 1655** AND HAVEN'T REPLACED A BEARING YET.

— RICHARD BOIRE - WESTLAND AGRO —

DURABLE. FUNCTIONAL. **RELIABLE.**

CONVEY-ALLTM

DURABLE. FUNCTIONAL. **RELIABLE.**

(800) 418-9461 | www.convey-all.com | conveyors@convey-all.com