

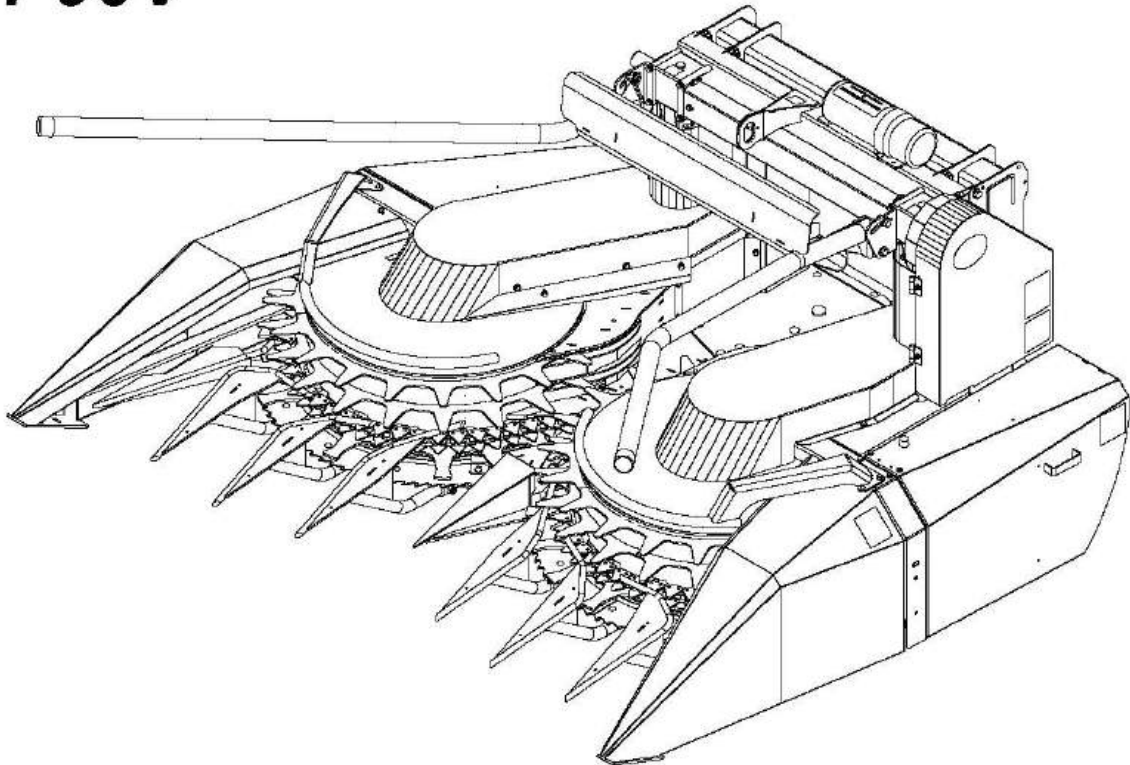

F64-90R
F64-90V



Operator's Manual
3-Row Rotary Corn Attachment



DION-AG INC. LIMITED WARRANTY TERMS AND CONDITIONS

Covered by Warranty – Under the warranty, Dion-Ag guarantees its new machinery and/or equipment to be free of defects, both in workmanship and material, for a period of one (1) year from the time of delivery by the dealer. Dion-Ag Inc. will repair or replace, at its discretion and without charge for service parts or labour, any defective part of the equipment on condition that the machinery and/or equipment has been operated in accordance with the instructions contained in the Dion-Ag Inc. Operator's Manual.

Not covered by Warranty – This warranty does not cover: (1) service parts and labour needed to maintain the unit; and (2) the replacement of parts due to normal wear and tear. The owner is responsible for these items. Some examples of maintenance and normal wear parts are: oil, lubricants & other fluids, belts, knives, clutch and clutch discs, roller chain, paddles, etc. Dion-Ag Inc. is not responsible for depreciation or damage caused by normal wear, lack of reasonable and proper maintenance, failure to follow operating instructions, misuse, lack of proper protection during storage, vandalism, the elements, collision or accident.

Securing Warranty Service – To secure warranty service, the purchaser must report the machinery and/or equipment defect to an authorized dealer and request warranty service within the applicable warranty terms.

Owner's Obligation – It is the responsibility of the Owner to transport the equipment to the service shop of an authorized Dion-Ag Dealer or to reimburse the dealer for any travel or transportation expense involved in fulfilling this warranty. This warranty does NOT cover rental of replacement equipment during the repair period, loss of profits, or other commercial loss, and any or all incidental or consequential damages, overtime labour charges and/or freight charges for replacement parts.

Limitations of This Warranty – No agent, employee or representative of Dion-Ag Inc. has the authority to amend, or modify, in any manner whatsoever, the terms of the present warranty. The express warranties herein contained exclude all other express, implied or statutory warranties. THIS WARRANTY IS IN LIEU OF ALL OTHER WARRANTIES INCLUDING THE WARRANTIES OF MERCHANTABILITY AND/OR FITNESS FOR ANY PARTICULAR PURPOSE.

Right to Inspect – Dion-Ag and its authorized agents reserve the right to inspect the purchaser's Dion-Ag product to determine if a defect in material or workmanship exists prior the commencement of any covered repairs. It is the purchaser's responsibility to ensure availability and/or delivery of the product to Dion-Ag for the purpose of inspection.

Right to Make Design Changes – Dion-ag reserves the right to make changes in the design and other changes in its products at any time and from time to time without notice and without incurring any obligation of its part to modify, improve or add to products previously ordered from Dion-Ag and sold or shipped by Dion-Ag.

Liability – Dion-Ag Inc. shall not be liable, if, during the use of the machinery and/or attachment, the security guards have been removed, modified, or have not been properly maintained.

The Warranty shall not apply if the instructions mentioned in this manual have not been followed completely and correctly. Nor will the warranty apply if the owner or any third party modifies the machine without Dion-AG's knowledge and/or authorization. Every purchaser, when buying a Dion-Ag machine, agrees and undertakes to use and operate the machinery and its component parts safely, and in accordance with all applicable laws, and in accordance with the Operator's Manual. Furthermore, the purchaser agrees and accepts to indemnify and hold harmless Dion-Ag for all losses and damages to any person or property resulting from the purchaser's non-compliance with the terms and conditions of this warranty. Each purchaser further agrees to bring the warranty to the attention of any subsequent purchaser, and to obtain agreement therein as a condition of resale or transfer.

F64 Rotary Corn Attachment

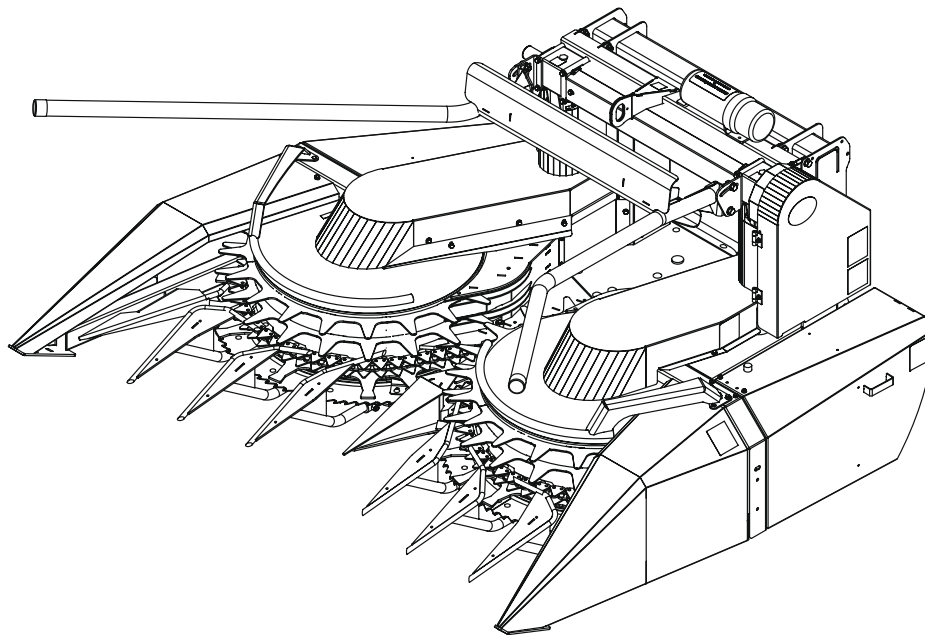

TO OUR CUSTOMER

We appreciate your confidence in DION Farm Equipment and thank you for your trust. In preparing this manual, we hope we have provided you with a valuable tool for operating and maintaining this fine machine. Use this manual as your guide. Following the instructions given here will result in many years of dependable service from your machine.

Your Dealer can give you assistance with parts and specially trained personnel to assist you in repair and maintenance.

Call your Dealer if you need any assistance or information.

SPECIFICATIONS.....	5
CHECK LIST	6
FOREWORD	7
SERIAL NUMBER LOCATION	8
SAFETY RULES.....	9
TRANSMISSION SHAFT OPERATION.....	1
STOPPING PROCEDURES.....	11
GUARDS AND SHIELDS	12
SAFETY DECALS	13
SAFETY SIGN APPLICATION PROCEDURE.....	14
INSTALLATION	15
RECEPTION (BY DE DEALER)	15
INSTALLATION OF THE ROTARY CORN ATTACHMENT ON THE FORAGE HARVESTER	17
OPERATING.....	20
OPERATING TIPS.....	20
OPERATING SPEED.....	20
BOLT TORQUE SPECIFICATIONS.....	20
MEASURING GAUGE	20
LUBRICATION.....	21
LUBRICATION CHART.....	21
CHAIN LUBRICATION.....	21
TIGHTENER ROD LUBRICATION	22
GEAR BOXES OIL LEVEL	22
TIGHTENER GREASING	22
OVERRUNNING CLUTCH GREASING	22
DRUM GREASING	23
ADJUSTMENTS - MAINTENANCE.....	24
GROUND CLEARANCE ADJUSTMENT.....	24
CONVEYOR CHAIN TENSION ADJUSTMENT	24
CONVEYOR CHAIN VERIFICATION	25
DRUM AND CONVEYOR CHAIN ADJUSTMENT	27
CHAIN SYNCHRONIZATION	28
CHAIN REPLACEMENT.....	29
INTERMEDIATE CHAIN TENSION ADJUSTMENT	29
DISK CLEANER ADJUSTMENT	30
KNIFE SECTION REPLACEMENT	30
DEFLECTOR-KNIFE REPLACEMENT	30
STRAIGHTENING UP THE DRUM FINGERS	31
CUTTING DISK BELT TENSION ADJUSTMENT.....	31
DEFLECTOR ADJUSTMENT	31
FRICTION DISKS REPLACEMENT	32
DRIVE BELT REPLACEMENT	33
DRUM ADJUSTMENT	33
SCRAPER ADJUSTMENT	34
MAINTENANCE SUMMARY	35
STORAGE	36
TROUBLESHOOTING	37

SPECIFICATIONS

Specifications and design are subject to change without notice
and without liability therefore

NOTE: Specifications apply only to the F64 model.

Shipping Dimensions	F64	F64 Dion	F64 John Deere™	F64 Gehl™	F64 New Holland™
Overall Length	192 cm (80")	211 cm (83.3")	217 cm (85.5")	226 cm (89")	212 cm (83.5")
Overall Width	222 cm (87.5")	222 cm (87.5")	222 cm (87.5")	222 cm (87.5")	222 cm (87.5")
Overall Height	122 cm (48")	122 cm (48")	122 cm (48")	122 cm (48")	122 cm (48")
Weight	705 kg (1550 lbs)	750 kg (1650 lbs)	725 kg (1600 lbs)	750 kg (1650 lbs)	735 kg (1620 lbs)

PRE-SEASON CHECKS

- Check condition of guards and knives
- Check condition of chains and chain guides
- Check chain tension and elongation
- Check condition and tension of drive belts
- Look for loose or missing bolts and parts
- Make sure no safety decal is missing and make sure they are readable
- Check condition of saw teeth
- Check condition of drum fingers. Make sure they are solid and straight
- Check oil levels on gear boxes

DAILY

- Check tension of belts and chains
- Clean machine
- Lubricate following instructions found in maintenance section
- Make sure all guards are in good condition

TO OUR CUSTOMER

The following pages and illustrations are printed to help supply you with the knowledge to better operate and service your F64 Rotary Corn Attachment.

Any piece of equipment needs, and must have a certain amount of service and maintenance to keep it in top running condition. We have attempted to cover all the adjustments required to fit most conditions; however, there may be times when special care must be taken to fit a condition.

Study this operator's manual carefully and become acquainted with all the adjustments and operating procedures before attempting to operate your new equipment. Remember, it is a machine and it has been designed and tested to do an efficient job in most operating conditions and will perform in relation to the service it receives.

If special attention is required for some conditions, ask your Dion Dealer; his parts and Service Organization will be glad to help and answer any questions on operation and service of your new machine.

THIS MANUAL SHOULD REMAIN WITH THE MACHINE WHEN SOLD

This manual was prepared from the latest product information available at publication time. The Company reserves the right to make changes at any time without notice.

The safety section of your Operator's manual is intended to point out some of the basic safety situations which may be encountered during the normal operation and maintenance of your F64 Rotary Corn Attachment, and to suggest possible ways of dealing with these situations. This section is NOT a replacement for other safety practices featured in other sections of this book.

WARRANTY INFORMATION

Your Dion Warranty for this machine appears in this manual, which you received from your dealer when you purchased the Box.

The equipment purchaser shall assume charges for service calls or transportation of equipment to and from the location of servicing Dion dealer.

SAFETY

The safety of the operator is one of the main concerns in designing and developing a new F64 Rotary Corn Attachment. Designers built in as many safety features as possible. However, every year accidents occur which could have been avoided by taking a more careful approach to handling farm machinery and implements.

Read and implement the safety instructions detailed in the safety section of this manual.

SERIAL NUMBER LOCATION

For your convenience, write down in full in this manual both the model and serial numbers of your machine, as shown on the name plate illustrated below. Always mention both the model and the serial numbers when ordering parts or regarding any other correspondence referring to your machine.

Write down your number here:

MODEL NO.	SERIAL NUMBER
<input type="text"/>	<input type="text"/>

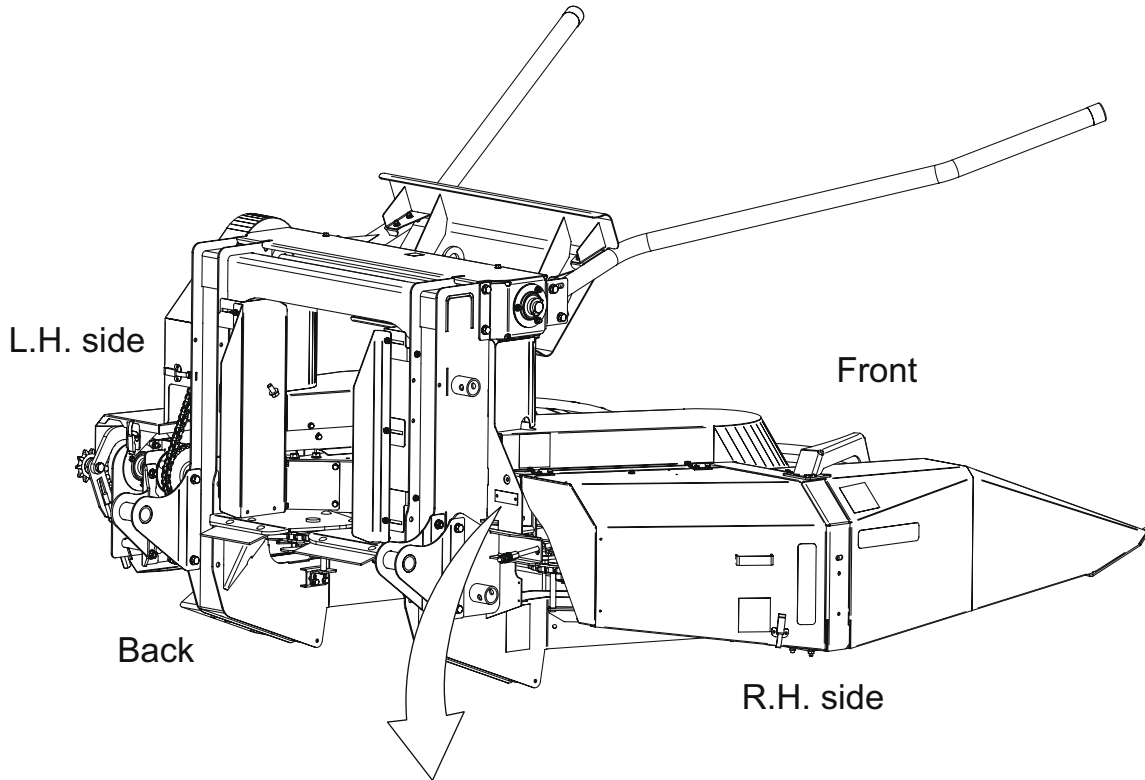

SAFETY ALERT SYMBOL



The symbol above calls your attention to instructions concerning your personal safety. It is found throughout the manual as well as on the machine to point out specific hazards and ways to avoid them. Always follow the instructions to minimize the risk of personal injury or death.

DANGER, WARNING AND CAUTION

Whenever you see the words and symbols shown below, used in this manual and on decals, you **MUST** take note of their instructions as they relate to personal safety.



DANGER: Indicates an imminently hazardous situation that, if not avoided, will result in **DEATH OR VERY SERIOUS INJURY**.



WARNING: Indicates a potentially hazardous situation that, if not avoided, could result in **DEATH OR SERIOUS INJURY**.



CAUTION: Indicates a potentially hazardous situation that, if not avoided, may result in **MINOR INJURY**.

IMPORTANT: The word **IMPORTANT** is used to identify special instructions or procedure which, if not strictly observed, could result in damage to, or destruction of the machine, process or its surroundings.

NOTE: The word **NOTE** is used to indicate points of particular interest for more efficient and convenient repair or operation.

SIGNS

WARNING: **DO NOT** remove or obscure *Danger, Warning, Caution safety signs or Instruction signs that are not readable or are missing. Replacement signs are available from your Dealer in the event of loss or damage. The actual location of these Safety signs is illustrated on pages 15 and 16.*

FOLLOW A SAFETY PROGRAM

For proper operation of a corn attachment, you must be a qualified and authorized operator. To be qualified, you must read and understand the written instructions supplied in this Operator's Manual, have training, and know the safety rules and regulations for the job.

Some local regulations specify that no one under the age of 16 years, for example, may operate power machinery. This includes tractors. It is your responsibility to know what these regulations are, and obey them, in the operating area or situation. These will include, but are not limited to, the following instructions for proper operation.



WARNING: *An operator should not use alcohol or drugs which can change their alertness or coordination. An operator on prescription or "over the counter" drugs needs medical advice on whether or not he or she can properly operate machines.*

A WORD TO THE OPERATOR

It is **YOUR** responsibility to read and understand the safety section in this manual before operating your tractor. You must follow these safety instructions that take you step by step through your working day.

In reading this section, you will note that illustrations have been used to highlight certain situations. Each illustration is numbered and the same number appears in the text in parenthesis. This number is placed at the end of the written text that refers to the illustration.

Remember that **YOU** are the key to safety. Good safety practices not only protect you, but also the people around you. Study the features in this manual and make them a working part of your safety program. Keep in mind that this safety section is written only for this type of machine. Practice all other usual and customary safe working precautions, and above all.

REMEMBER - SAFETY IS YOUR RESPONSIBILITY. YOU CAN PREVENT SERIOUS INJURY OR DEATH.



WARNING: *In some of the illustrations used in this Operator Instruction Book, panels or guards may have been removed for clarity. Never operate the machine without these components in position. If the removal of panels or guards is necessary to make a repair, they **MUST** be replaced before operation.*

- Disengage the PTO and shut off engine before leaving the operator's seat for refuelling, lubricating or adjusting the machine.
- The tractor engine ignition key must be removed each time the operator leaves the tractor.
- Wear appropriate clothing, safety boots or shoes. Do not operate the machine when visibility is bad, or during night, in poor lighting.
- When driving on a public road, or on hilly land you must remove the electrical box ignition key and put the locking pin in the stop pawl of the quick-disconnect hitch to prevent unlocking. This locking pin should also be used for the manual quick-disconnect hitch.
- Attach a safety chain of at least 20,000 lbs (9071 Kg) capacity for transportation.
- Keep children away from the machine at all times. Maximum traveling speed of a forage harvester should not exceed 20 mph (34 km/h).
- Carefully read all safety signs applied on the machine. If they are damaged, replace them immediately.
- If a feeding or throwing mechanism should become jammed, never attempt to unblock it or remove any material when the machine is in motion or the tractor engine running.
- Never manually feed the rotary corn attachment.
- Never remove guards or make adjustments while the machine or tractor engine is running.
- Never attempt to check or adjust chains while the machine is running.
- Keep hands and feet away from the pick-up chains and the saw.
- Make sure all rotating parts are stopped and the tractor engine is turned off before cleaning the machine throat.
- Never park the attachment in the transportation position. Lower the attachment to the ground first.
- Before starting the tractor engine, make sure all guards, shields, and doors are in place and properly secured and check the machine thoroughly for possible loose parts or bolts and tighten them.
- Always pick-up tools after performing any adjustment.
- Never allow riders on any part of a machine.
- Block elevated components before servicing equipment.
- Never lubricate or clean any part while the machine or tractor engine is running.
- Keep hands and body out of hitch area when attaching towing vehicle.



WARNING: *Hydraulic fluid under pressure can penetrate the skin or eyes and cause serious personal injury, blindness or death. Fluid leaks, under pressure, may not be visible. Use a piece of cardboard or wood to find leaks. DO NOT use your bare hand. Wear safety goggles for eye protection. If any fluid is injected into the skin, it MUST be surgically removed within a few hours by a doctor familiar with this type of injury.*

- Securely block the wheels from moving before working on or under the machine.
- Use a lift system with a minimum capacity of 2,000 lbs (900 kg) to install the attachment on a forage harvester.
- Never pull a full box behind a forage harvester when driving on a public road.
- Make sure to meet local regulations regarding wide loads on public roads.

TRANSMISSION SHAFT OPERATION

- POWER-TAKE-OFF DRIVE - Before starting the tractor engine make sure that the PTO locking device is properly engaged onto both the tractor and equipment PTO shafts.
- Never wear loose clothing and keep people, especially children away from the PTO.
- Do not hook a 1000 RPM tractor on a machine equipped with a 540 RPM drive and/or a 540 RPM tractor on a machine equipped with a 1000 RPM drive.
- Never proceed to the starting of the machine before making sure all PTO, machine and tractor, shields are well installed in place.
- The PTO shields should turn freely, be well connected and kept in good condition.
- Never step across any driveline.
- Never use the driveline as a step.
- Keep at least your height away from a rotating driveline

STOPPING PROCEDURES

No matter what type of machine is being used, it is extremely hazardous to perform any kind of maintenance work while the machine is running. Before cleaning, adjusting, or greasing, the following procedures should be followed to stop the attachment:

1. Lower the attachment to the ground.
2. Set the transmission to neutral.
3. Disengage the tractor power-take-off (P.T.O.).
4. Stop the tractor engine.
5. Engage the tractor parking brake.
6. Wait until all rotating parts are totally stopped.
7. Remove the P.T.O. from tractor output shaft.
8. Block all equipment wheels.



DANGER: Rotating driveline contact may cause serious injury or death.

GUARDS AND SHIELDS - FIGURES 1 TO 3

The rotary corn attachment is equipped with guards and shields wherever an accident is likely to take place. These guards and shields do not affect the machine performance. Several safety decals are affixed on the machine to remind of potential dangers

Bolted guards cover the driving belts (items 1 in figure 1).

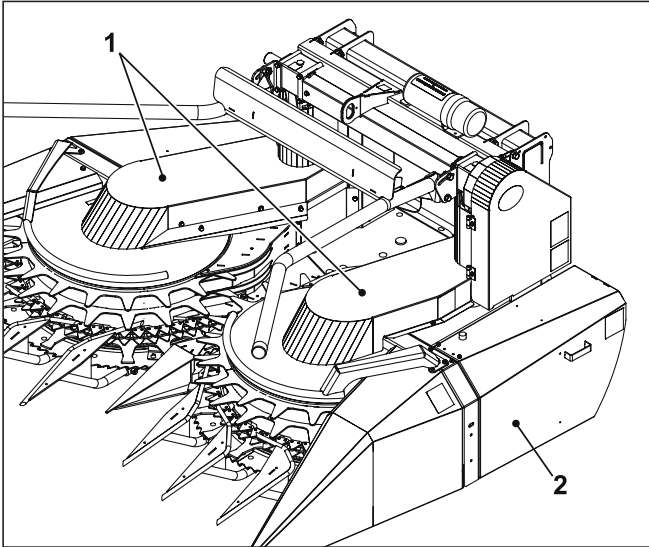

Figure 1 Drive belt guards (1) and drive chain guard (2)

Hinged guards cover the driving chains (items 2 in figures 1 and 2).

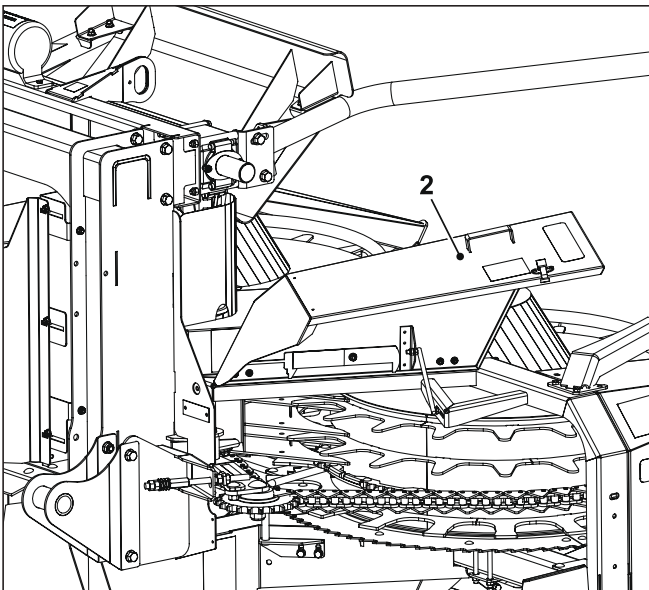

Figure 2 Drive chain right guard

An hinged guard covers the intermediate chain (item 3 in figure 3).

An hinged guard covers the drive shaft (item 4 in figure 4).

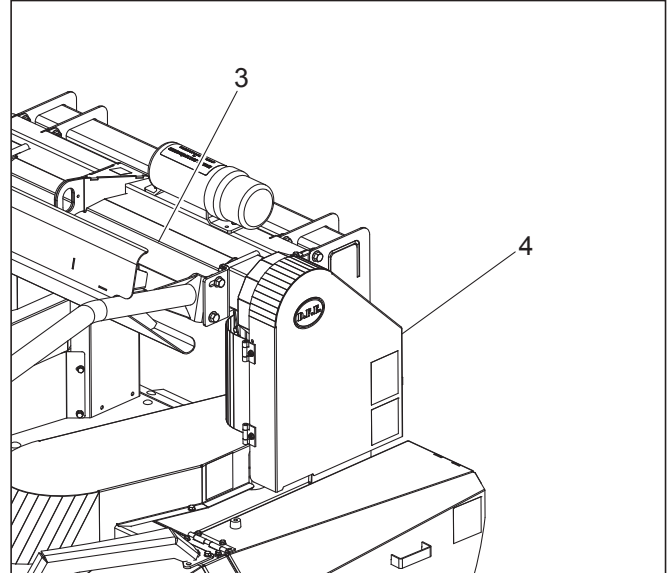

Figure 3 Intermediate chain guard (item 4) and drive shaft guard (item 3)



CAUTION: All guards and shields factory installed should be in place and maintained in good condition.

SAFETY DECALS

IMPORTANT: All safety decals should be in place and maintained in good condition. Decals should be readable at all times.

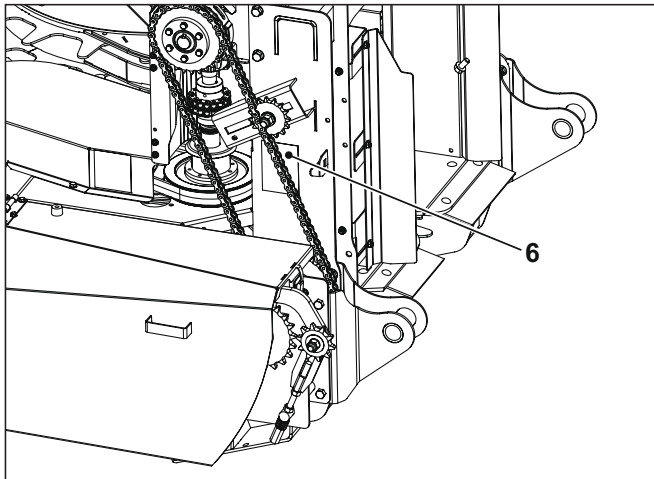
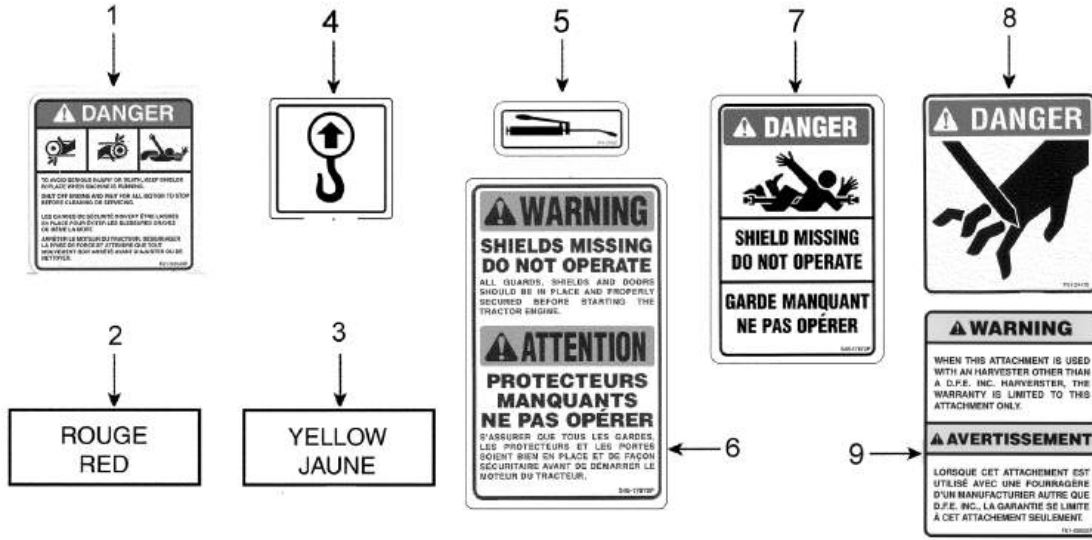

Figure 4 Safety sign location

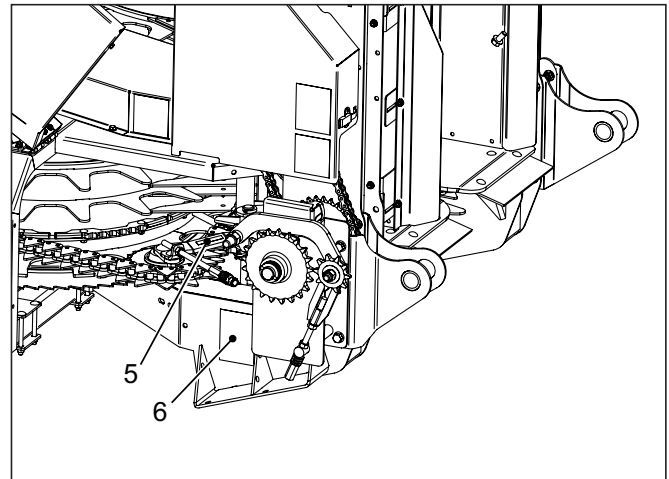

Figure 6 Safety sign locations

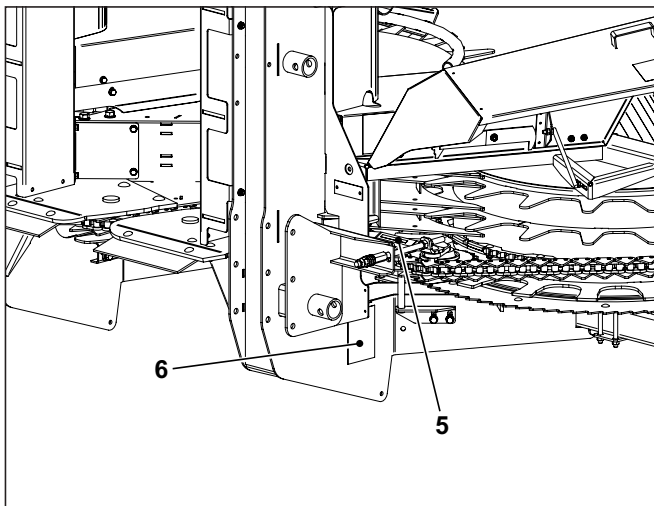

Figure 5 Safety sign locations

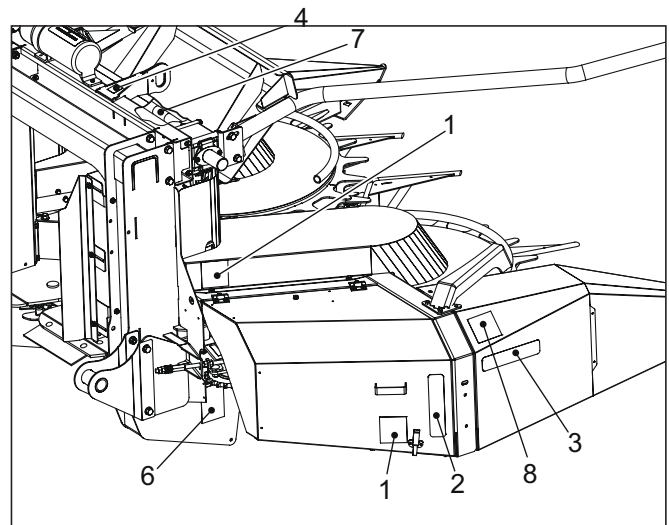

Figure 7 Safety sign locations (R.H. side)

SAFETY SIGN APPLICATION PROCEDURE

1. The surface should be free from dirt, grease, earth, or any other foreign material.
2. When the surface is dry, remove a portion of the backing paper and apply the decal in part and align its position as per the surrounding parts. Slowly peel off the remaining backing paper and apply hand pressure.
3. Press slightly on the surface of the safety sign to remove all air bubbles.

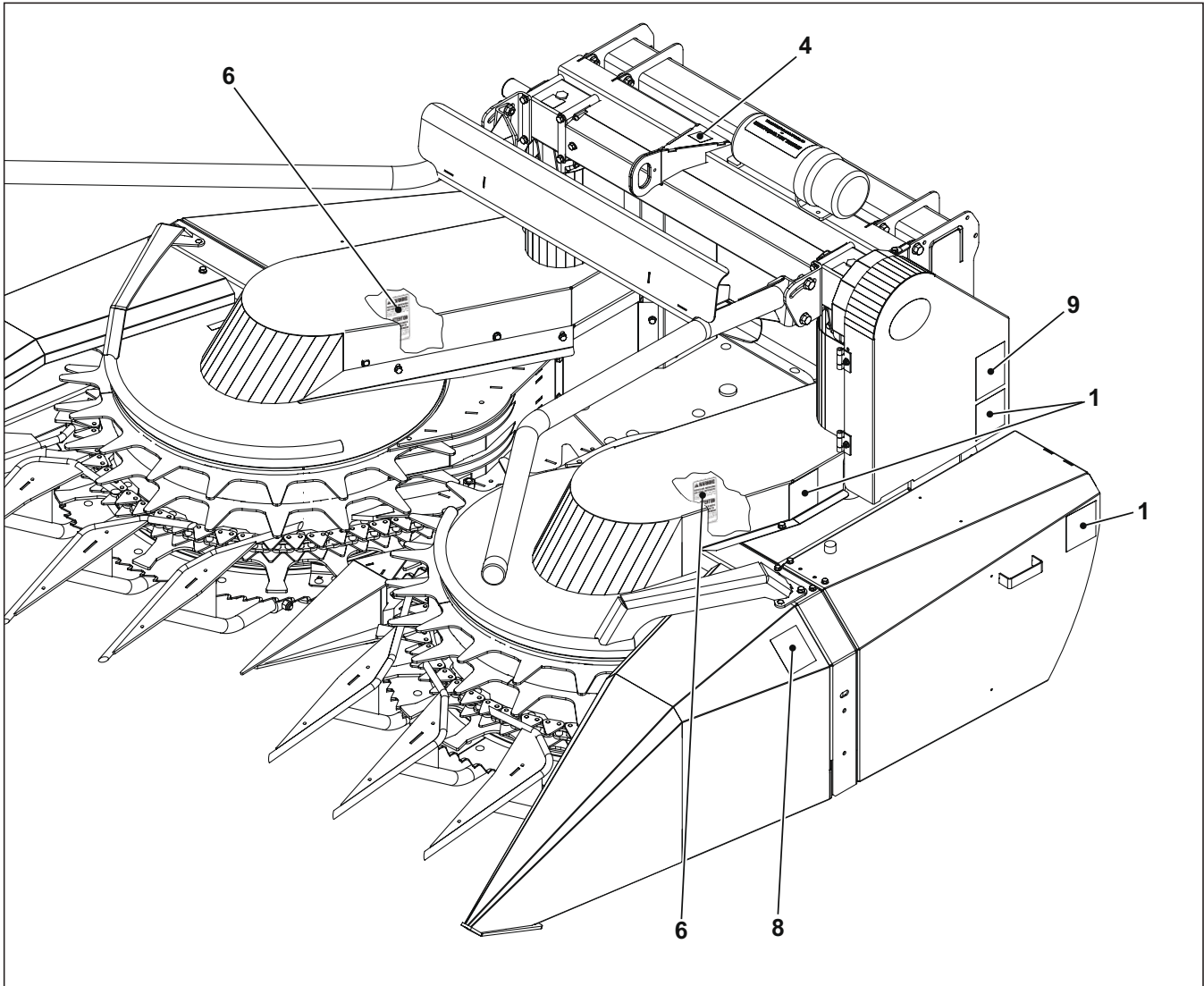

Figure 8 Safety sign location (L.H. side)

RECEPTION (BY DE DEALER)

The F64 Rotary Corn Attachment is delivered to the dealer on a shipping skid (item 1) normally accompanied by a box (item 2) containing the adaptor kit for the client's harvester model. Long forks (2.25 m or 8') must be used to lift the skid from the short side. A note is present on the skid. Standard 1,2 m (4') forks are sufficient to lift from the long side. The lift must have a capacity of 1,8 t (4000 lbs) to lift the skid from the short side.

1. Place the skid on a flat and level surface.
2. Remove the box containing the adaptor kit (item 2). The Attachment is delivered with a temporary lifting arm for the removal of the skid (item 3).

IMPORTANT: The lifting arm (item 3) should not be used for moving or lifting the attachment. It should only be used for laying it flat on the ground.

3. Before removing the skid, make sure bolts (item 4) on disks, fingers and knife deflectors.
4. Pass a chain (item 5) with a minimum capacity of 2000 lbs (900 kg), in the arm hook and make a closed and safe loop in the chain.
5. Follow standard safety rules for the operation of forklift, chain-block and chains to proceed.
6. With the lift of chain-block, slowly lift and pull on the chain to pivot the head to the ground.
7. Remove the chain (item 4).
8. Remove the bolts holding the Attachment and the skid together.

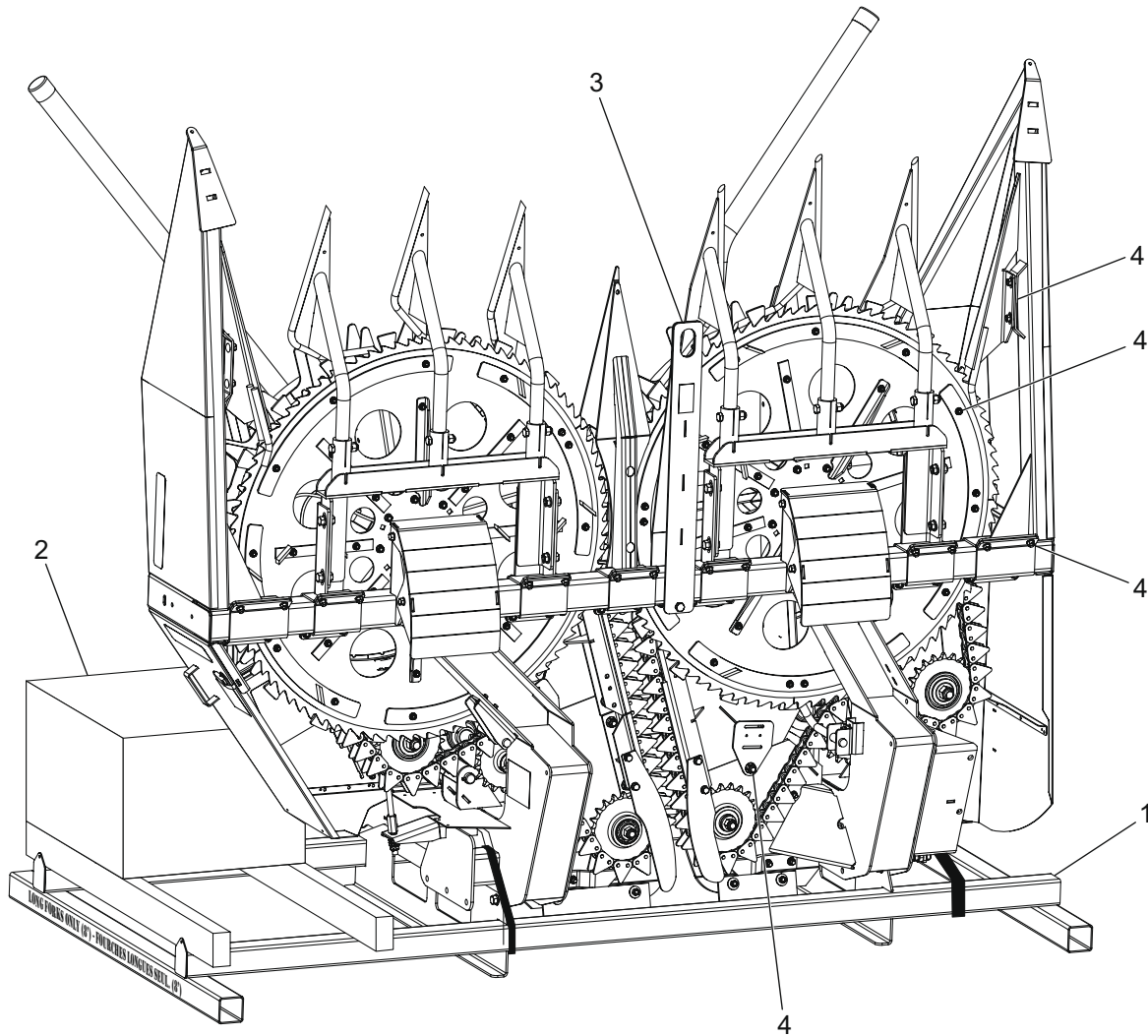

Figure 9 The 3-Row Rotary Corn Attachment in shipping position

9. The lift arm can now be removed and the Attachment may be lifted using the hook on top of the frame. The installation is done by the dealer before delivery to the client. Contact your Dion representative if needed.
10. Refer to the installation instructions of the adaptor provided in the box.

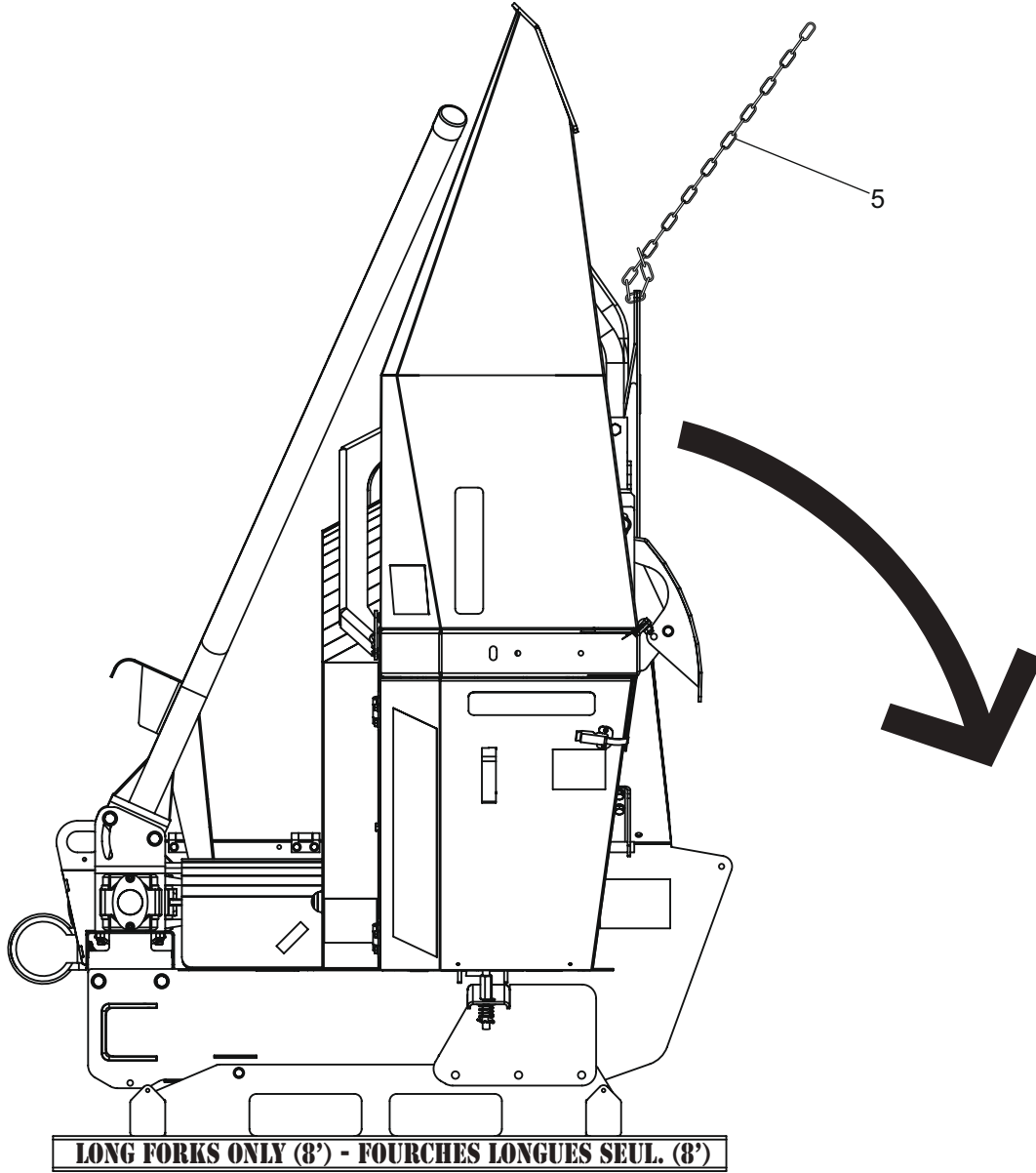

Figure 10 The 3-Row Rotary Corn Attachment in shipping position

INSTALLATION OF THE ROTARY CORN ATTACHMENT ON THE DION FORAGE HARVESTER

NOTE: Refer to the Forage Harvester operator's manual for brands other than Dion.

NOTE: Always remove tension on balancing springs before installing or removing attachment from Forage Harvester.

Make sure the Forage Harvester and the rotary corn attachment are standing on a flat terrain.

The rotary corn attachment is equipped with a support (figure 11) to lift attachment up for proper installation. The minimum lifting load must be 2000 lbs (900 Kg).

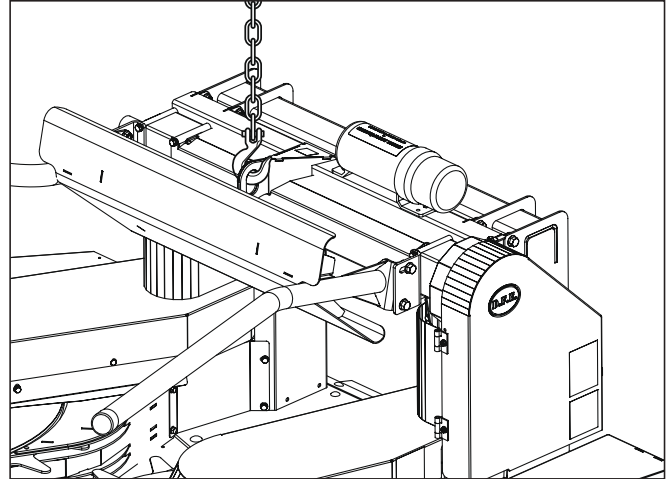

Figure 11 Lift support

1. Attach a chain to the lift support (figure 11).
2. Measure the corn attachment opening (figure 12) and adjust if necessary.

! IMPORTANT: If the throat sides on the attachment are bent or damaged, it is necessary to repair them so they will not come in contact with the feed rolls

3. Slowly move the Forage Harvester toward the attachment (figure 13), making sure it is well centered with respect to the connecting pins.
4. Align and adjust the attachment throat sides between the Forage Harvester sides and the feed rolls (figure 14).
5. When the attachment is set in place on the Forage Harvester, put the square lock pins and the safety pins back in place (figures 15 and 16). It will be necessary to install two floating springs and to move the bracket in the middle lifting hole.
6. Adjust both balancing springs (figure 17). The purpose of the balancing springs is to counterbalance the weight of the attachment either to slightly touch the ground or ease the attachment hydraulic lifting to avoid possible obstacles in the field. The tension of these springs must be adjusted to obtain approximately 80-100 lbs (36-45 Kg) at the end of the fingers.

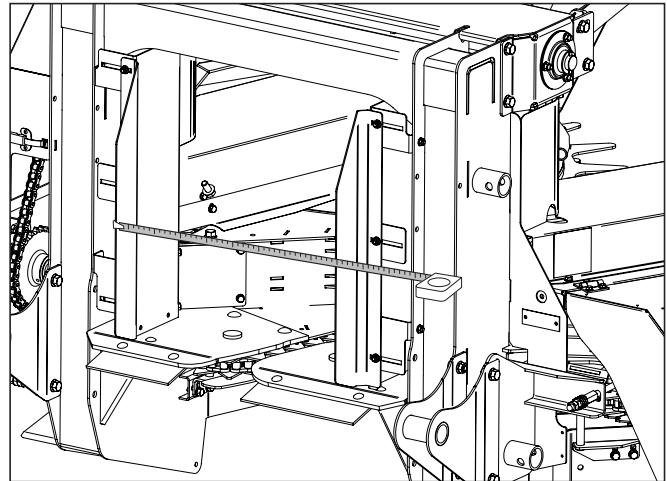

Figure 12 Adjustment

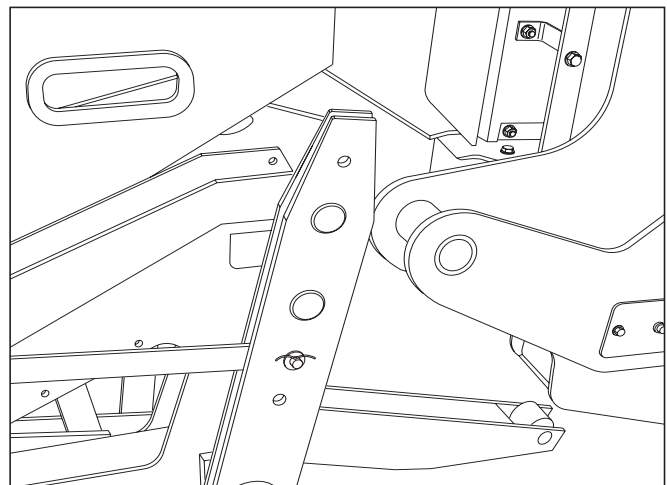

Figure 13 Move attachment toward Harvester

INSTALLATION

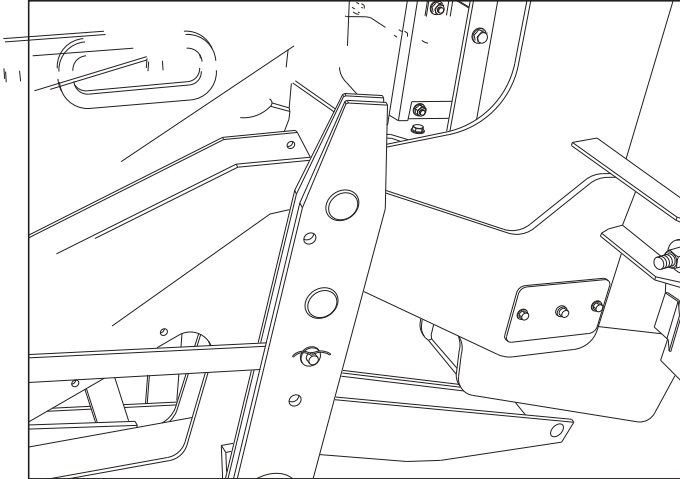

Figure 14 Align

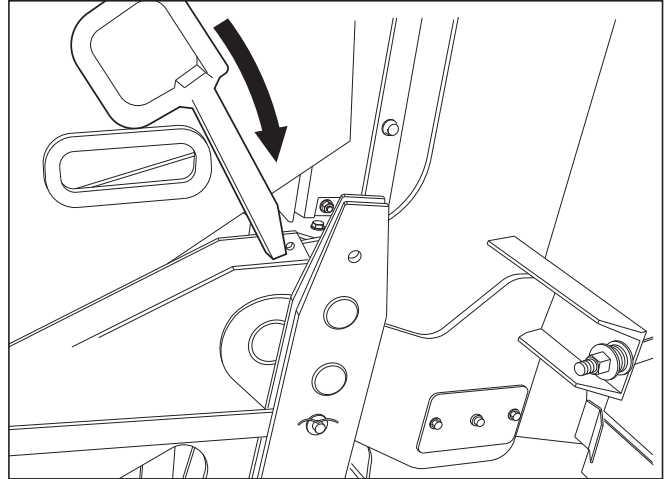

Figure 16 Square lock pin in place

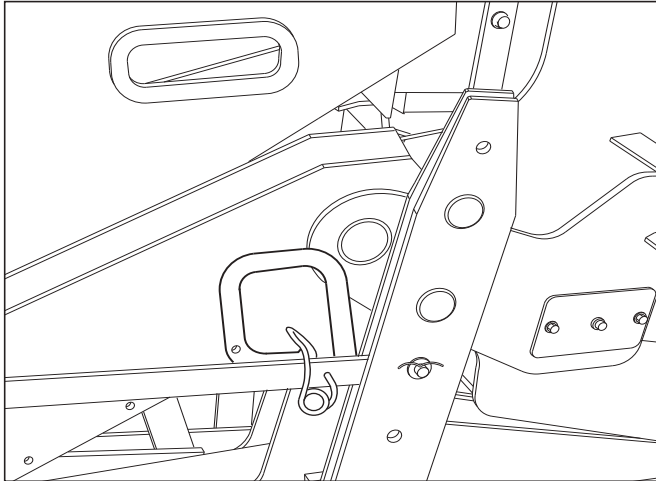

Figure 15 Insert square lock pins

7. Adjust the springs (item 1) by turning the screw (item 2) sleeves (item 4) with the handle (item 3). Two (2) balancing springs are required to operate your attachment. Bolt the spring bracket (item 5) on the attaching bar (item 6) as shown. Tighten bolt (item 7) well then install both balancing springs.
8. Adjust the cylinder stroke to prevent the attachment from touching the feed rolls.

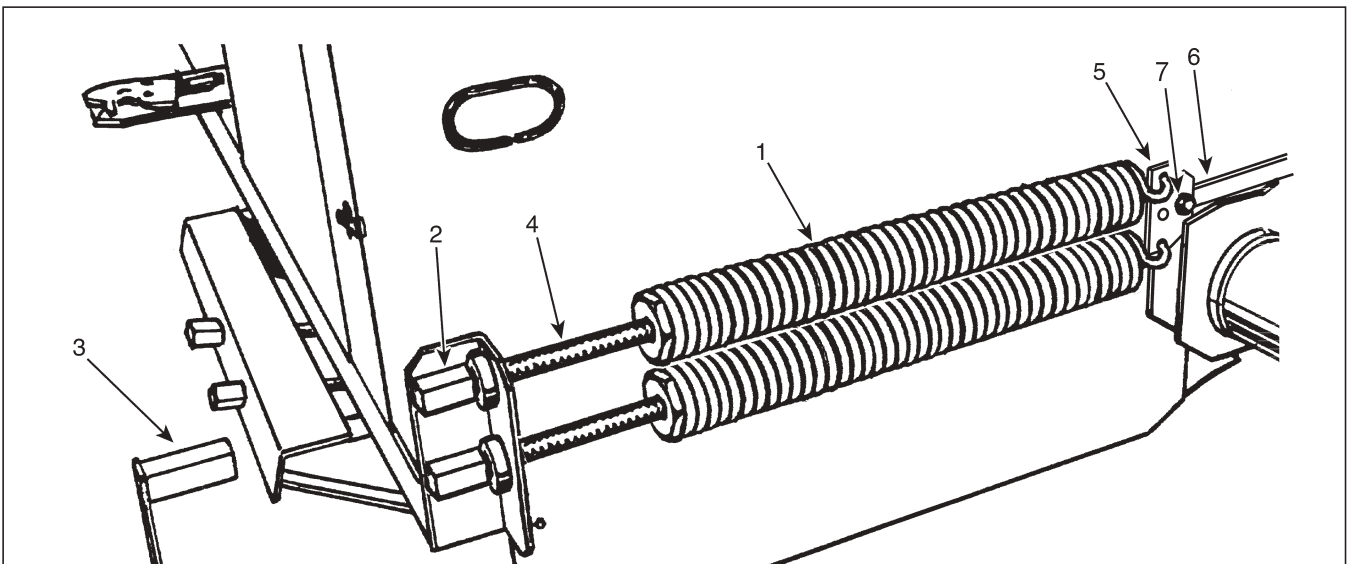

Figure 17 Balancing springs set-up when using a Rotary Corn attachment

INSTALLATION

9. Install the rotary corn attachment drive chain (item 1, figure 18). Use the #60 X 36 3/4" lg (93cm) chain with a #60 connecting link (1) or a #80 X 37" chain, depending on the Forage Harvester configuration.

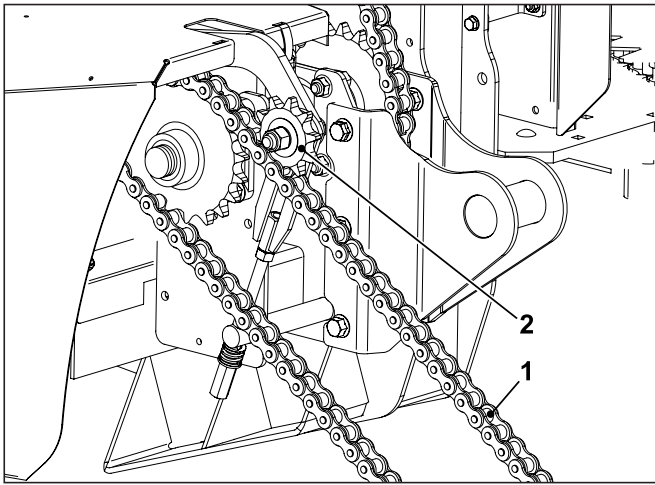

Figure 18 Installing the drive chain

NOTE: The #80 sprocket is standard on the attachment. As for the #60 sprocket, it must be specified when machine is ordered (item 5, figure 19).

10. Adjust the Forage Harvester lifting arms in operating position. Bring the chain underneath the tightening sprocket (item 2, figure 18) as shown. Align the drive chain. Adjust the chain to a normal tension, loosen nut (item 4, figure 19), tighten tightener nut (item 3, figure 19) then tighten nut (item 4, figure 19).

NOTE: On Forage Harvester models prior to 2006, it will be necessary to cut out a notch in the Forage Harvester transmission guard (figure 20) or to order a new guard

NOTE: On NH and CASE IH Forage Harvesters, install the PTO to start the machine.

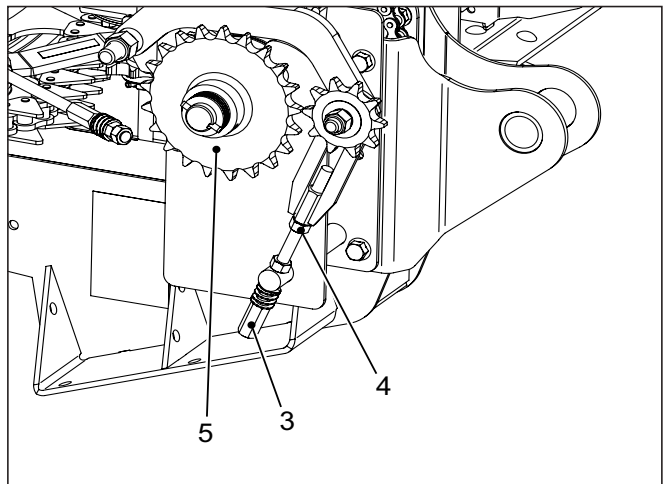

Figure 19 Drive chain tension

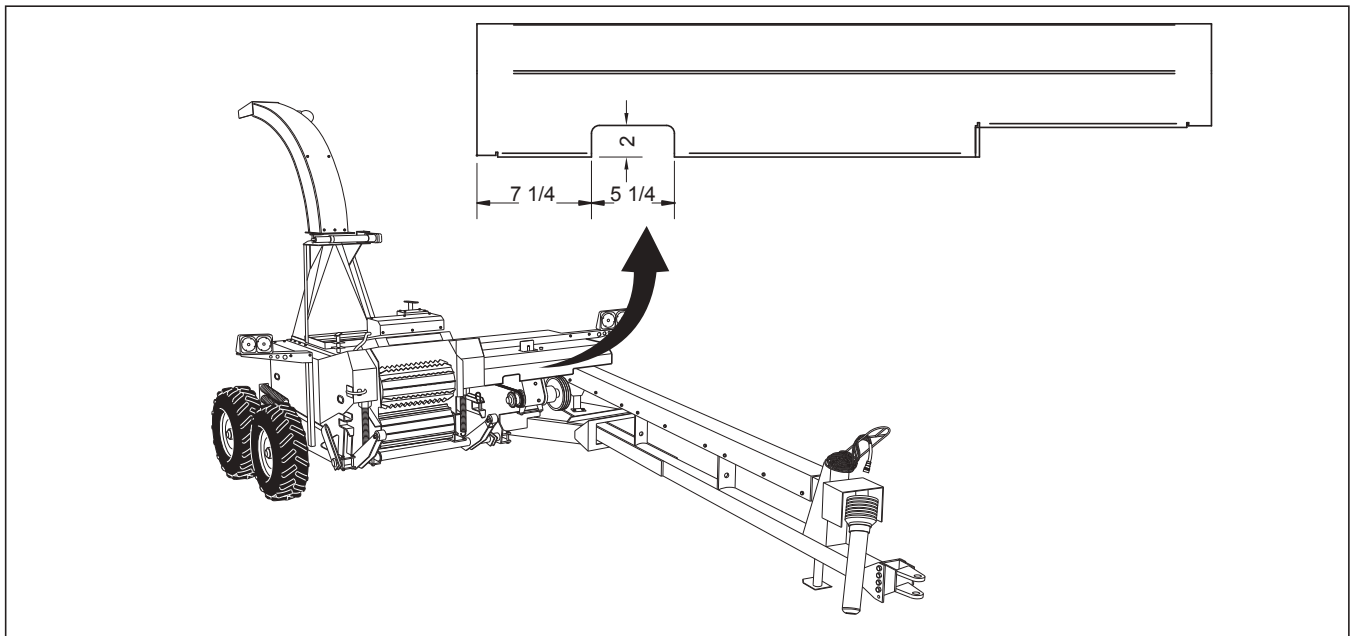

Figure 20 Transmission guard modification

OPERATING TIPS



WARNING: Before operating the Rotary Corn attachment, make sure that all safety rules are observed by people working with or near this machine. Refer to pages 11 to 16.

NOTE: Generally, it is recommended to be careful and to proceed to all necessary adjustments before operating the Rotary Corn attachment.

START-UP AND BREAK-IN



WARNING: Make sure that all guards or shields are in place and properly secured before starting the tractor engine.

1. Operate the machine at reduced speed for one or two minutes, then for five minutes at operating speed.
2. Verify and eliminate any contact, knocking or friction of the disk, drum or chain with the scrappers or any other component. Refer to the Adjustment section if necessary.
3. Run the machine in reverse for three to five minutes and make the necessary adjustments in order to eliminate any potential contact and friction.

After the first few hours of operation, check the following items. Chains and other moving parts will require an adjustment after the break-in period.

- Adjust the chain tension (refer to the Adjustment section).
- Lubricate the chain (refer to the Lubrication section).
- Locate and adjust the cleaning components and the scrappers in order to eliminate any possible knocking and friction.



WARNING: Always make sure tractor engine is switched off and attachment is secured before carrying out an adjustment around or under machine.

BOLT TORQUE SPECIFICATIONS

The table below gives correct torque values for bolts used on the machine. Check tightness of bolts periodically. Replace hardware with the same grade bolt.

BOLT DIA	SAE-2		SAE-5	
	Ft-Lbs	N.m	Ft-Lbs	N.m
1/4"	6	8	9	12
5/16"	10	13	19	25
3/8"	20	27	33	45
1/2"	45	61	80	110
5/8"	95	128	160	215
3/4"	170	230	280	380

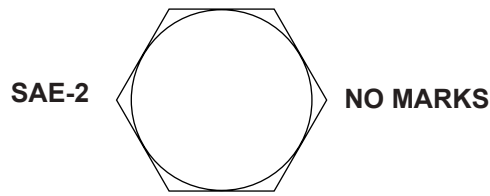
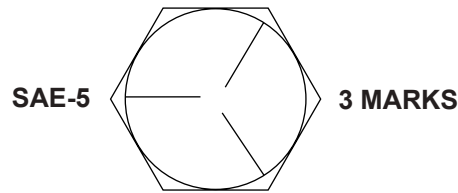

MEASURING GAUGE - FIGURE 21

A measuring gauge is located under the conveyor chain right guard. This gauge is needed to measure the stretch of the conveyor chain.

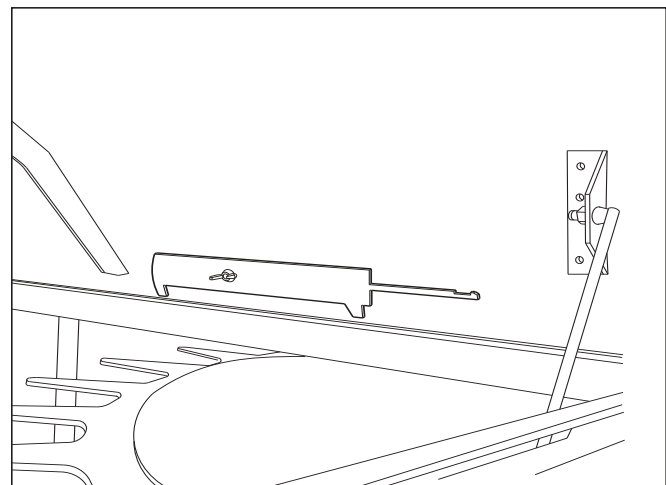





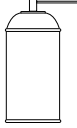

Figure 21 Measuring gauge



CAUTION: Never lubricate and/or clean any part while the machine and/or the tractor engine is running.

LUBRICATION CHART

These symbols indicate the specific points which must be lubricated, greased and verified.

SYMBOL	DESCRIPTION	FREQUENCY
Black on white 	Chain tightener - 2 places	Grease every 8 hours of operation
Black on white 	Over-running clutches 2 places	Grease every 40 hours of operation
	Drum bearings - 8 places	Grease every season
 SAE30 or equivalent	Roller chains and tightening rod 3 places	Grease every 40 hours of operation and before storage
	O-ring safe spray oil for conveyor chains F61-26340P	Every 8 hours of operation, at the end of the day and of the season F61-26340P
 80W90 or equivalent	Oil level - Gear box 2 places S55-24592P	Verify at beginning of each season and every 40 hours of operation

Greasing: Grease the chain tightener every day and the over-running clutches under the guard approximately every 40h. Over-greasing the clutches may impair their proper function. The gathering drum bearings (4 each) are greasable. They are lubricated at the plant and do not require any regular greasing. Greasing before and after each harvest is sufficient.

CHAIN LUBRICATION - FIGURES 22 AND 23

Lubricate the drive chains (figure 22) every 40 hours of operation or at the end of the season, before storage. Use SAE30 oil or equivalent.

NOTE: Use spray oil (F61-26340P) every 8 hours of operation and at the end of the season to lubricate the conveyor chains (figure 23).



WARNING: Never approach moving drums.

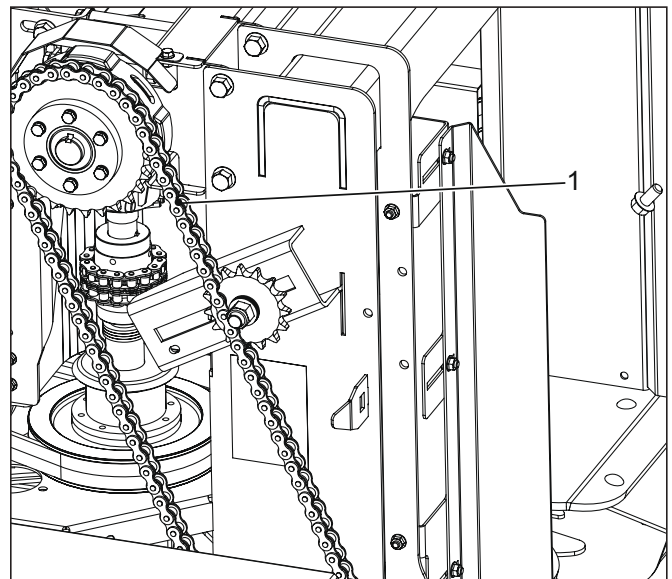

Figure 22 Intermediate chain (item 1)

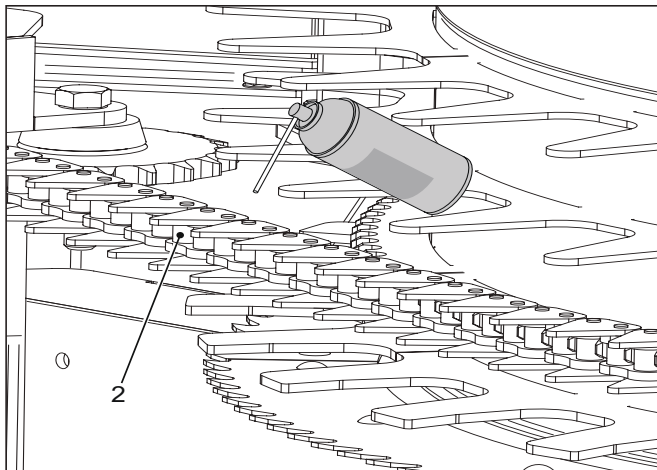

Figure 23 Conveyor chain (item 2) lubricated with spray oil

TIGHTENER ROD LUBRICATION FIGURE 24

Lubricate the tightener rods (items 3 & 4 in figure 24) every 40 hours of operation or at the end of the season, before storage. Use SAE30 oil or equivalent.

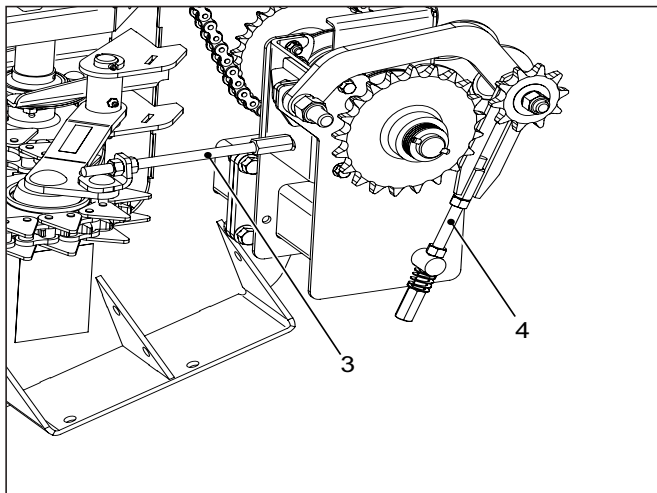

Figure 24 The chain tightener rods - on both sides of machine (3 places)

GEAR BOXES OIL LEVEL - FIGURE 25

IMPORTANT: Check oil level in gear boxes before each season and every 40 hours of operation.

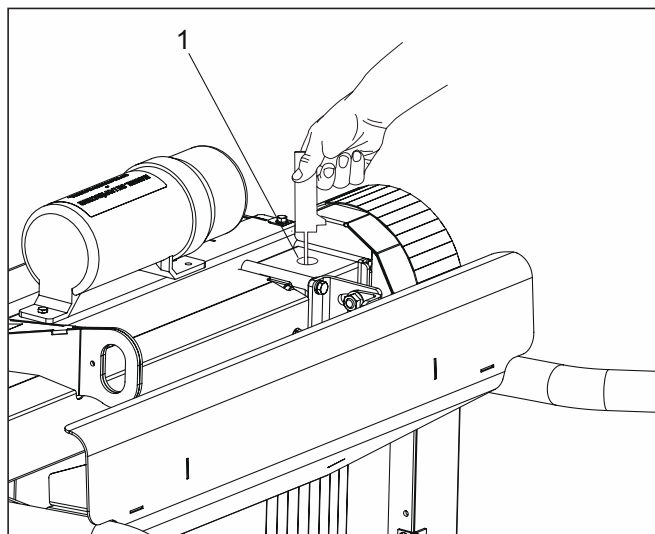

Figure 25 Checking gear box oil level with gauge (supplied)

TIGHTENER GREASING

Grease the chain tightener pivots located under the left and right guards with one pump stroke every 8 hours.

OVERRUNNING CLUTCH GREASING

Grease the overrunning clutches located under the belt guards. Refer to the greasing decal to locate grease fittings. Grease every 40 hours and avoid over-greasing which could damage the clutches.

DRUM GREASING - FIGURES 26 AND 27

To ensure longer bearing life, grease the drum bearings at the beginning and end of each season (4 on each drum). The lower bearing is accessible under the skid and the two internal bearings are accessible through the top (see figures 26 and 27). The upper bearing is located under the belt guard (figure 27).

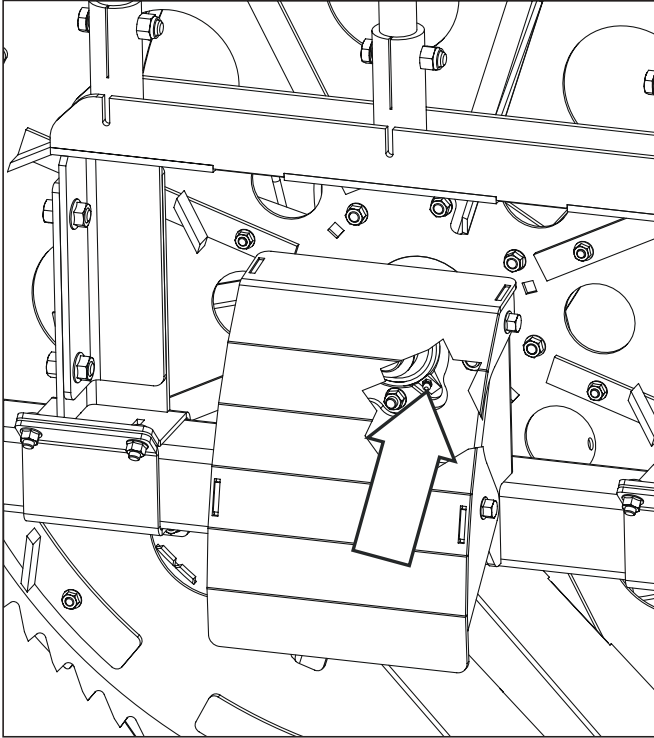

Figure 26

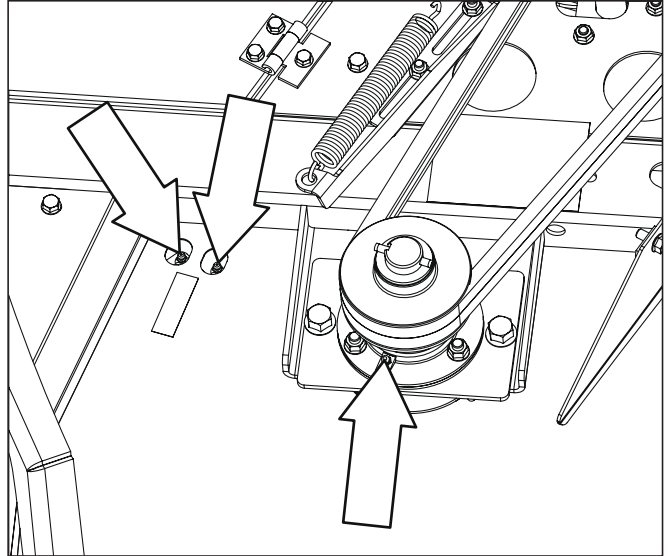

Figure 27

NOTE: Keep in mind that any maintenance or adjustment described in this manual is the owner's sole responsibility.



WARNING: Never remove guards or make adjustments while machine and/or tractor engine is running.



WARNING: After making adjustments, check the machine very carefully for possible loose parts or bolts. Make sure all guards, shields, and doors are in place and properly secured before starting the tractor engine.



CAUTION: Never perform work on the Rotary Corn attachment without first lowering it to the ground and applying tractor brakes.

NOTE: If it is necessary to service the bottom of the machine, safely raise machine with blocs (see safety section).

GROUND CLEARANCE ADJUSTMENT

In order to prevent an early wear of the machine or a mechanical break down, it is important to adjust the ground clearance. For corn harvest, it is recommended to adjust the ground clearance to 12 inches (30 cm).

This is the actual distance between the ground and the saw blade. This adjustment is done through the Forage Harvester's hydraulic system.

CONVEYOR CHAIN TENSION ADJUSTMENT FIGURE 28 TO 31

IMPORTANT: The conveyor chains must be adjusted before each day of operation and **after the first breaking-in hour.**

NOTE: Same procedure on the left side.

The maximum chain play must be approximately 1/4" (6 mm). This measure must be taken at the center of the chain, as shown in figure 28.

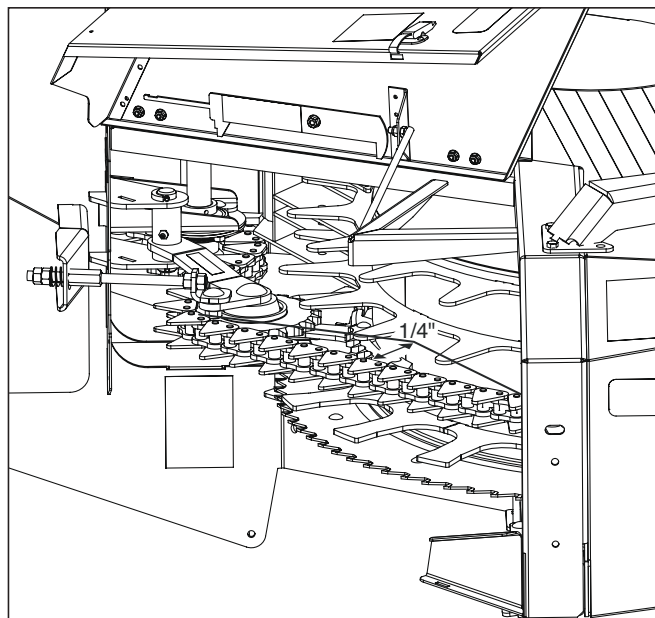

Figure 28 Maximum chain play

A spring (item 3) absorbs shocks during operation (figure 31). Check spring tension. It must be pre-compressed between 19 and 22 mm (3/4" to 7/8"), **when the chain is completely loosen.**

NOTE: This same adjustment must also be carried out on the input chain tightener spring (Figure 19).

To tighten the chain, simply loosen nut (item 1 in figure 29) and then tighten bolt (item 2 in figure 30) until chain tension is appropriate or until nut (item 1) no longer touches support bracket (item 4 in figure 30). Gap should be the two should be approximately 1/16" (2 mm) as shown. Tighten nut (item 1).

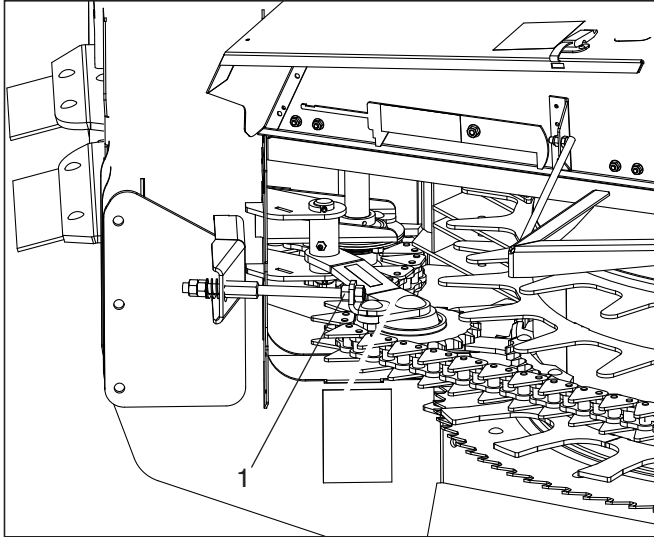

Figure 29 Loosen nut (item 1)

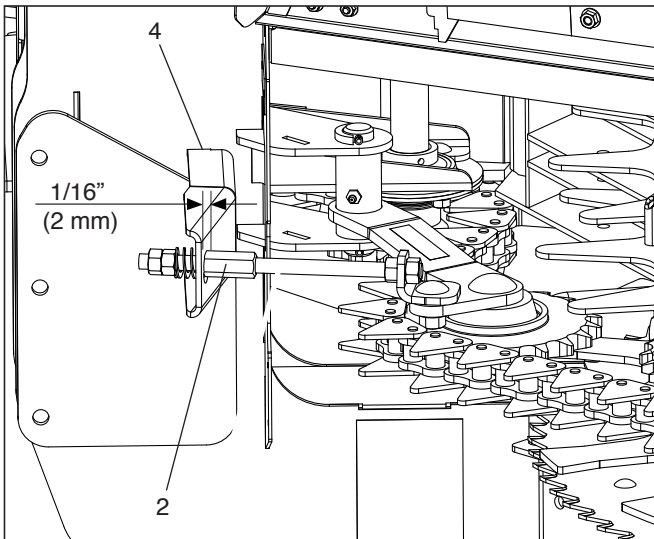

Figure 30 Tighten bolt (item 2)

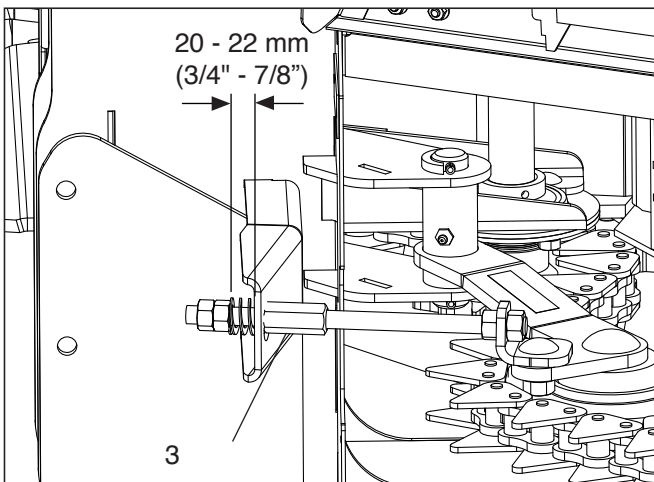

Figure 31

CONVEYOR CHAIN VERIFICATION FIGURES 32, 33 AND 34

Check chain stretch every 40 hours of operation or at the end of the season. When chain stretch exceeds 1.5%, drum sprocket sections must be adjusted as shown further. Use the special gauge located under the right chain guard (figure 32). This gauge is supplied with the attachment and is used for checking chain stretch.

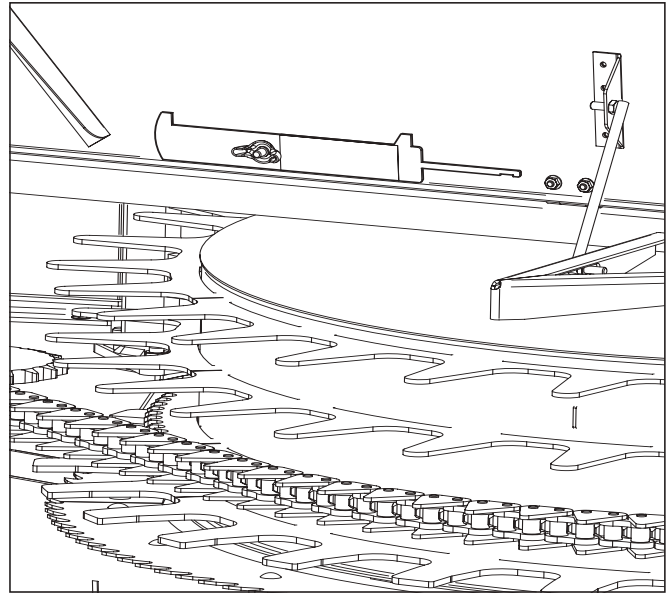

Figure 32 Chain gauge

Set gauge on chain as shown in figure 33. The left side of the gauge must rest against one of the rivets as shown in figure 34. The chain must be adjusted when one of the rivets (on the left) is resting on the chain gauge as shown in figure 34.

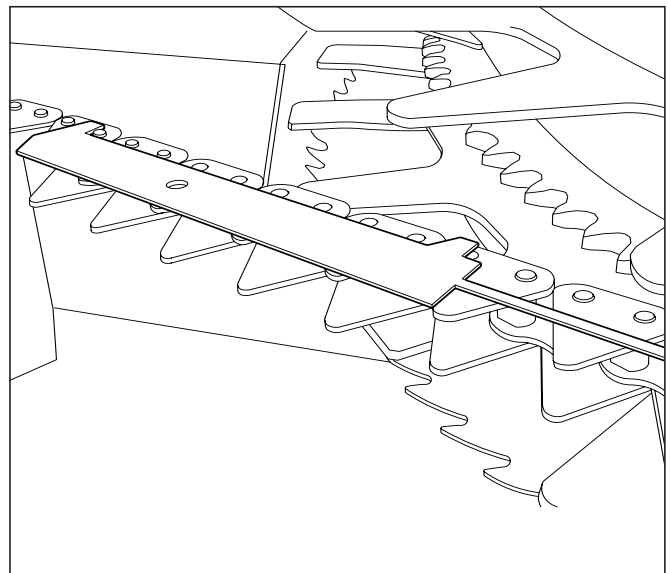
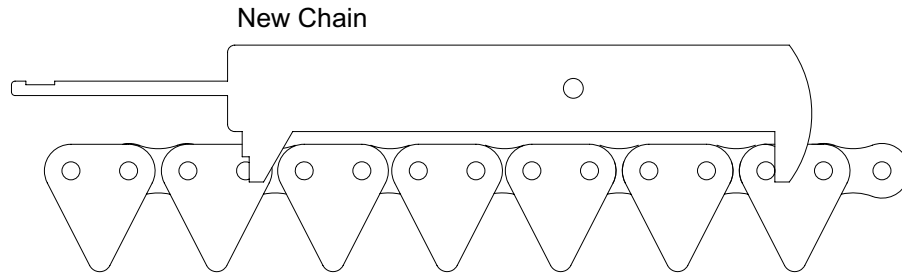
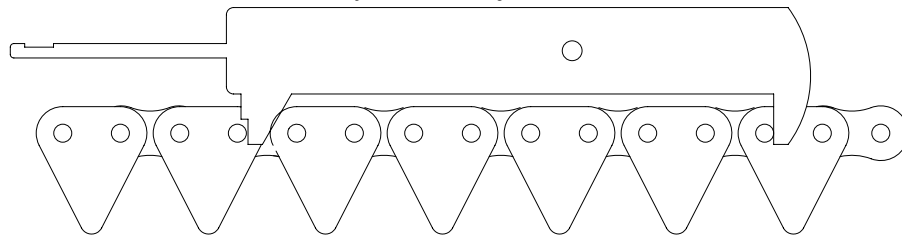

Figure 33 Measuring chain stretch

ADJUSTMENTS



1.5% wear, adjustment of drum sprocket sections.
See conveyor chain adjustment section in this manual.



3% wear, replace conveyor chains and refer to the chain replacement
section in this manual to readjust the drum sprocket sections.

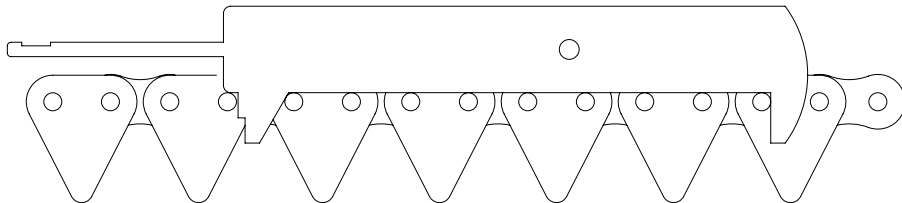

Figure 34 Measuring chain stretch

**DRUM AND CONVEYOR CHAIN
ADJUSTMENT - FIGURES 35 TO 37**

Check chain stretch every 40 hours of operation or at the end of the season. Conveyor chains can tolerate a 3% stretch before having to be replaced. However, when half-worn, tension will not be maintained adequately on the drums. The driving wheel on the drum is made of 8 detachable sections. To extend the chain's life, it is possible to move the sections to compensate for the chain stretch. Two sections are fixed and the others are adjustable.

Drum section adjustment must be carried out only when chain is sufficiently stretched. Use gauge (figure 32) to check chain stretch (figures 33 and 34).

Adjustment procedure:

1. Disengage corn attachment drive from harvester.
2. Lift guards on both sides to access rear of drum.
3. Loosen tighteners to release chain tension (item 1, figure 35).
4. Using a 1/2" wrench, loosen the free teeth section (figure 36).
5. Slide section clockwise (viewed from above, on both drums) while pushing firmly on the end of the adjustment slot. These slots are longer from one section to the other. This way, the chain will have skipped a tooth at the 2nd fixed section.
6. Repeat this procedure for all 8 sections. Rotate drum against its normal operating direction. Note that 2 sections are fixed and require no adjustment.
7. The chain has two coupling links (figure 37). These links are found by turning the drum by hand, then remove link.
8. Readjust the chain tension. Check tension again after machine has been running for a few minutes.
9. Repeat procedure on the other drum.

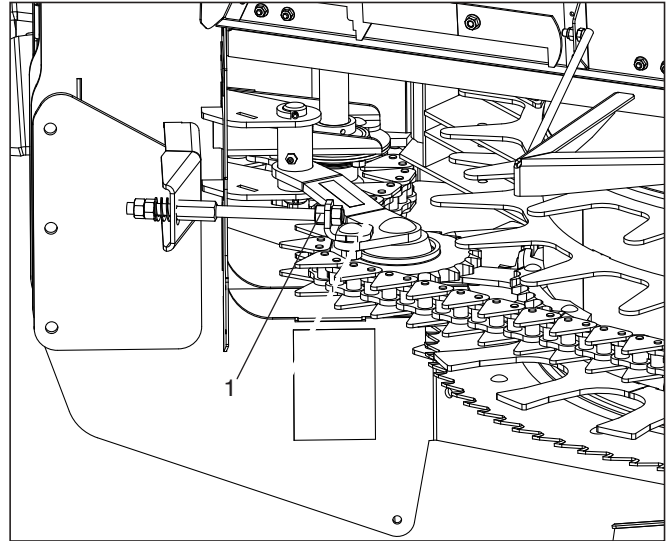

Figure 35 Loosen chain tightener

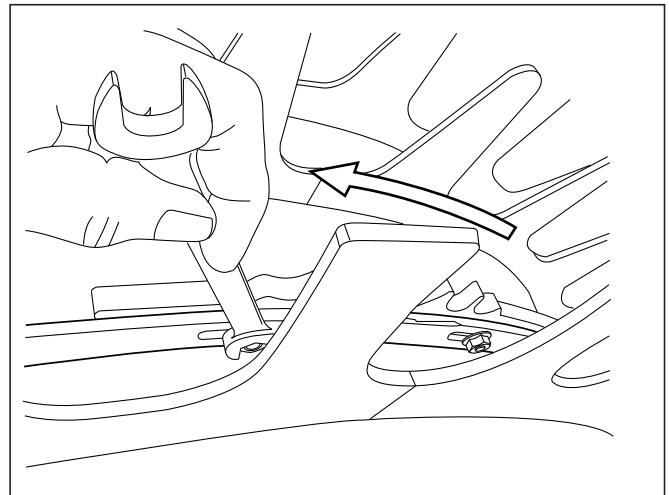

Figure 36 Move the teeth sections

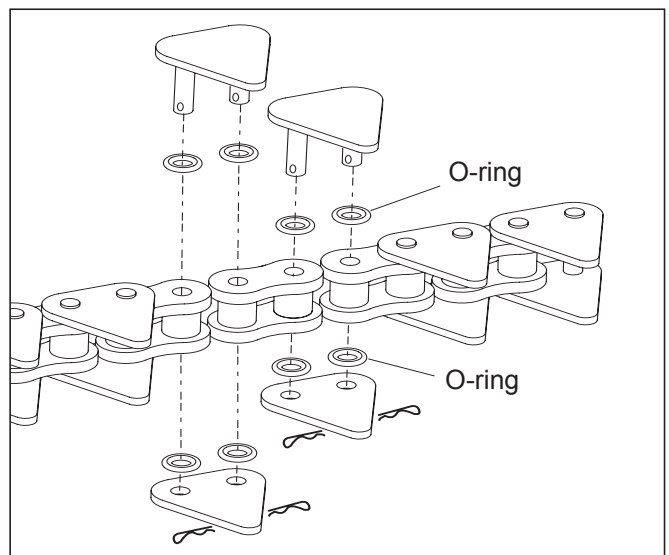

Figure 37 Special chain link and O-rings

**CHAIN SYNCHRONIZATION
FIGURES 38 AND 39**

When a new conveyor chain is installed, it is important to synchronize both conveyor chains. The chains are synchronized when the teeth on both chains are perfectly centered with one another, as shown in figure 8.

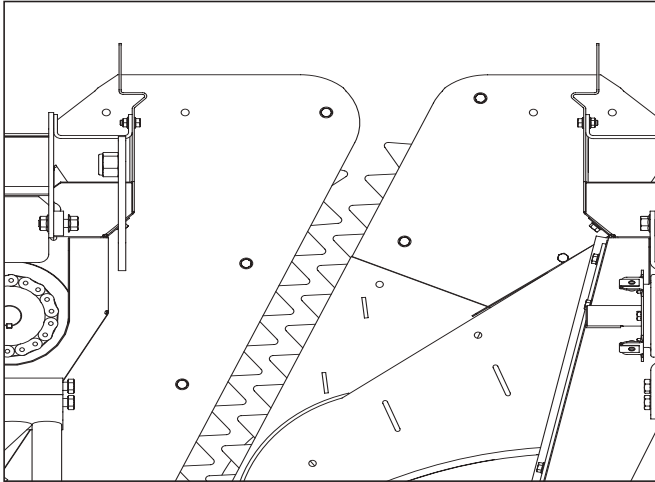

Figure 38 Synchronized conveyor chains

Gears are synchronized at the assembly line. Synchronization is not required in case of a chain replacement. Simply install the new chains in the same position as the old ones. If the chain tension is not properly adjusted, synchronization may be lost and the chain could skip a tooth over the drive sprocket. To solve this problem, simply remove chain tension completely and move the chain until it reaches the appropriate position on the sprocket.

When replacing the belts or for any other reasons, it may be necessary to remove the chain from the couplers (item 1 figure 39) located underneath the gear boxes. To easily re-synchronize the conveyor chains, mark with a line the alignment of the coupler teeth (item 1 figure 39)

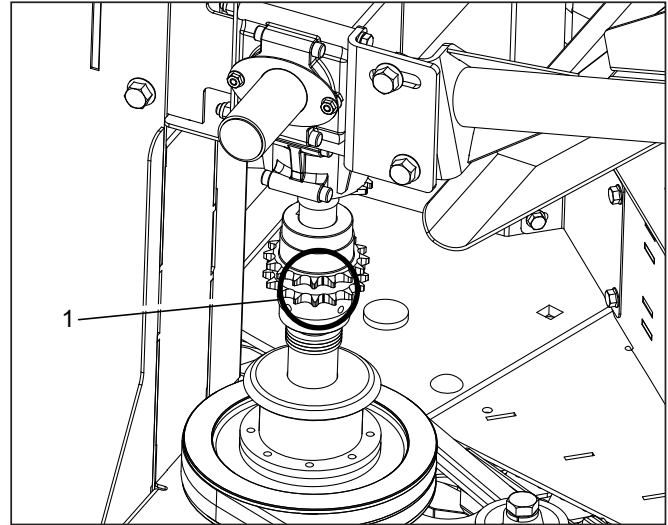

Figure 39

To synchronize, it is much easier to adjust only the position of the right vertical shaft. First, slightly loosen the chain tensioner (item 1, figure 33). With the coupler chain removed, slowly rotate the right drum in order to move the right chain forward in relation with the left chain. It will be easier to achieve this by also removing tension on the left chain. When the conveyor chain links are well off-set, check to see if the teeth on the coupler are also aligned. Rotate the drum until the chain and coupler teeth are perfectly aligned for a perfect synchronisation.

NOTE: The synchronisation is satisfactory when the conveyor chain links are interleaved (figure 38) and the coupler teeth are well aligned (figure 39).

CHAIN REPLACEMENT - FIGURES 40 AND 41

When the chain is overly stretched (figure 34) and a first teeth adjustment has been carried out, it must be replaced.

IMPORTANT: Teeth sections need to be at their initial position (figure 38) before a new chain is installed.

Replacement position:

1. Loosen the chain tightener.
2. Remove the connecting link.
3. Remove the chain completely.
4. Check chain slides for wear (item 2 in figure 40) and replace if necessary.

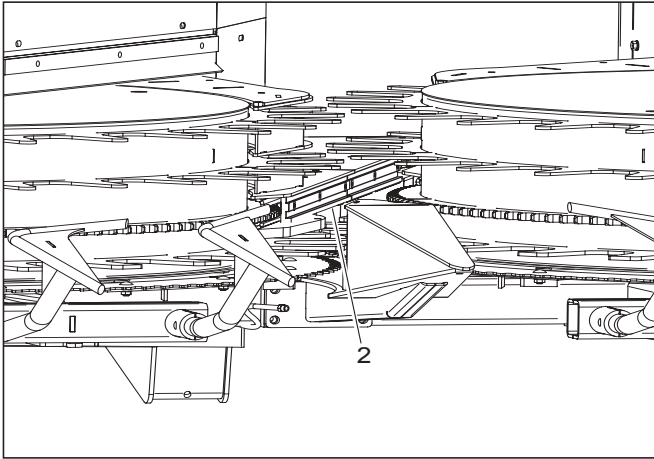

Figure 40 Chain slide bar

5. Reposition the teeth sections on the drum. Loosen each section then slide to the right (counterclockwise as shown in figure 41) in the adjustment slot.

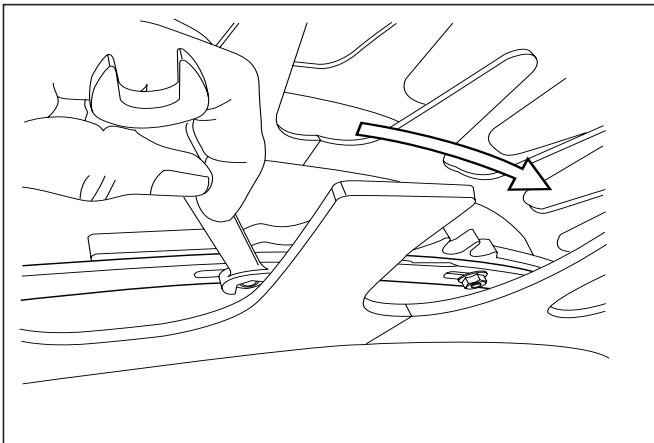

Figure 41 Moving teeth sections

6. Install the new chain with the special link and the O-ring (figure 37).
7. Synchronize the chains if necessary.
8. Tighten the chains.

INTERMEDIATE CHAIN TENSION ADJUSTMENT - FIGURE 42

The intermediate chain must be kept tight at all times. Regularly check chain play and adjust if necessary. The chain play should not exceed 1/4" (6 mm). This measure must be taken in the center of the chain. Check chain play after the first hour of operation and at the end of the season (or after 40 hours of operation).

To tighten the chain, simply loosen nut (item 1) and then move the sprocket until the chain is tight. Tighten nut (item 1).

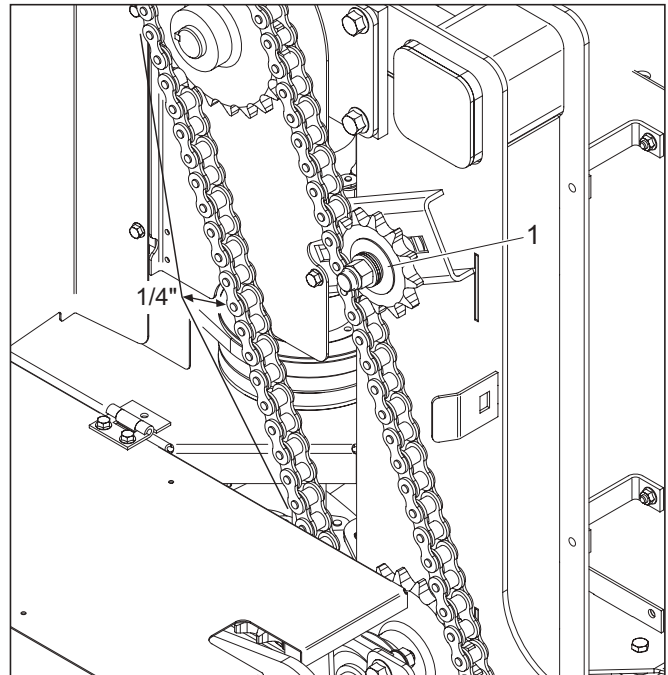

Figure 42 The intermediate chain

**DISK CLEANER ADJUSTMENT
FIGURE 43**

To prevent debris accumulation and material jam, regularly check and adjust the disk cleaning forks located on the lateral fingers. Adjust so that the gap between the tip of the teeth and the cleaner is kept at 1/4" (6 mm) or less but without ever touching the disk.

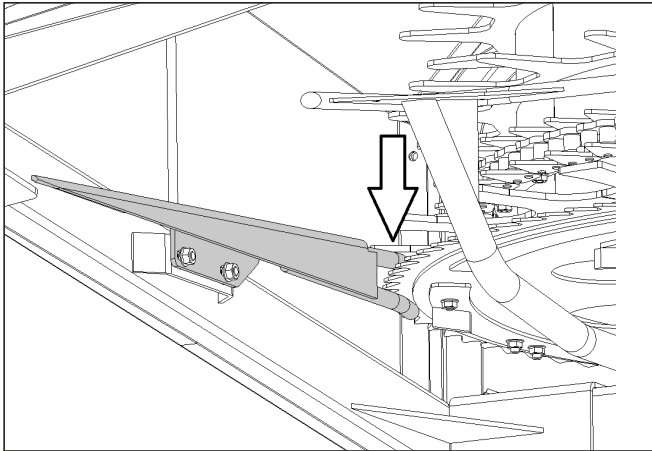

Figure 43 Disk cleaners

**KNIFE SECTION REPLACEMENT
FIGURES 44 AND 45**

Each knife is made of 4 sections. Each section can be replaced individually. These sections are made from tempered steel for extended life. In case of failure or premature wear, they can be replaced as described below.

1. Remove the four bolts holding the knife section.
2. Remove the reinforcement plates under the disk.
3. Replace the section then install the reinforcement plates back under the disk with the four bolts supplied with the knife.
4. Tighten all bolts back.

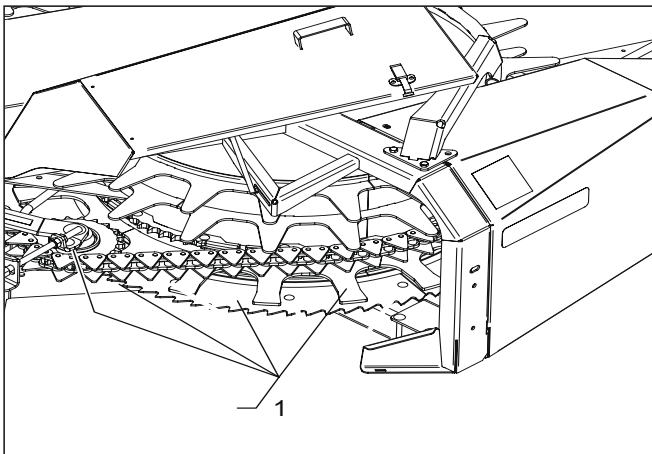

Figure 44 Removing the four bolts

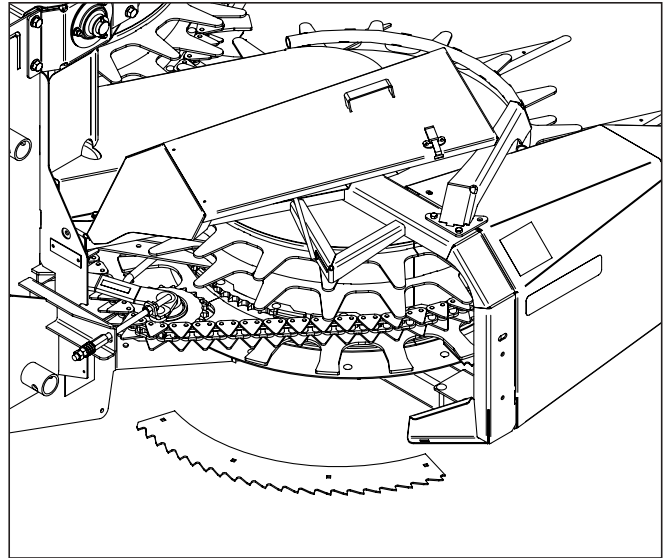

Figure 45 Replacing a knife section

**DEFLECTOR-KNIFE REPLACEMENT
FIGURE 46**

The deflector-knives are installed under the disks (around the edge or on the spokes) to prevent debris built-up on the machine frame. These deflector-knives must be replaced if they are broken or worn out. It is important to follow the deflector-knife configuration in order to maintain the machine's good working order and to keep the saw balanced.

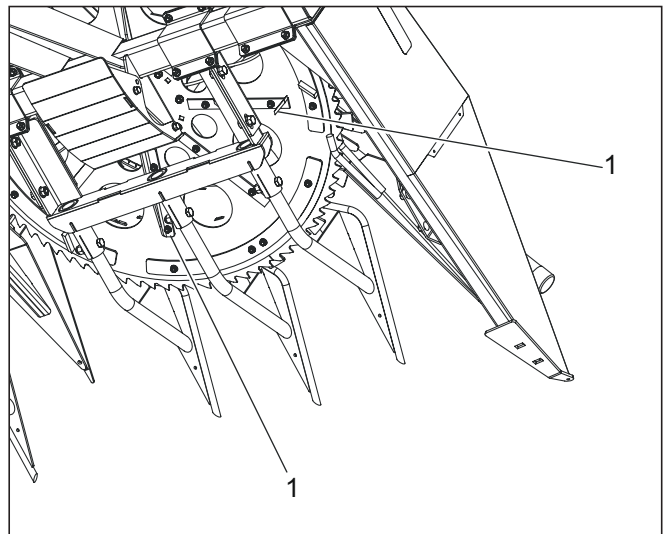

Figure 46 The deflector-knives

**STRAIGHTENING UP THE DRUM FINGERS
FIGURE 47**

It is possible for one or more drum fingers to bend during operation. Use an adjustable wrench to straighten the drum fingers, as shown in figure 47.

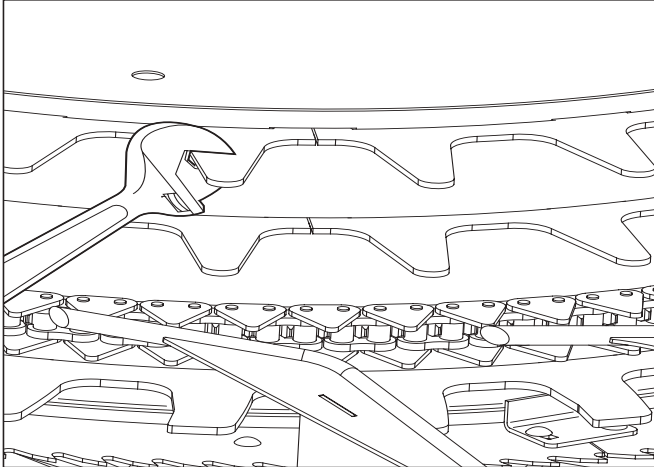

Figure 47 Straightening up drum fingers

**CUTTING DISK DRIVE BELT TENSION
ADJUSTMENT - FIGURES 48 AND 49**

1. Regularly clear debris that may accumulate under the belt guards.
2. Keep approximately 1/16" (1.5 mm) between the spring coils (item 1) by moving the bolt (item 2) on which the spring is hooked to.
3. Adjust the stopper (item 3) by adjusting the distance between the stopper and the tightener between 1/16" and 1/8" (1.5 to 3 mm). The adjustment is done by moving the stopper from one hole to the other and by turning it inside the eccentric hole.

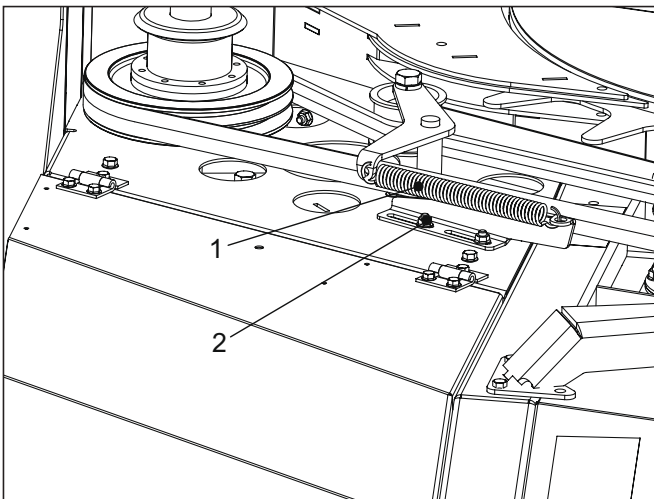

Figure 48

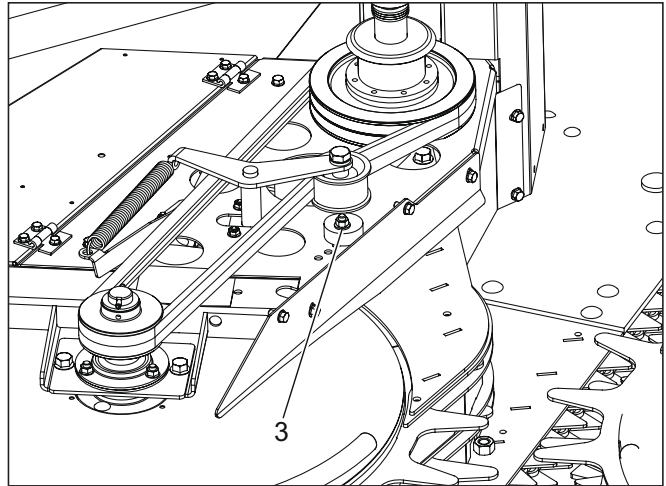

Figure 49

DEFLECTOR ADJUSTMENT - FIGURE 50

Deflectors (item 1) must be adjusted according to the corn's height. Position the deflectors so they are just above the horizontal when operating in normal conditions.

In case of a very dry corn crop, raise the deflector tubes above the ears of the corn to avoid contact which could result in some corn falling to the ground. Use the lower position only for very short harvests.

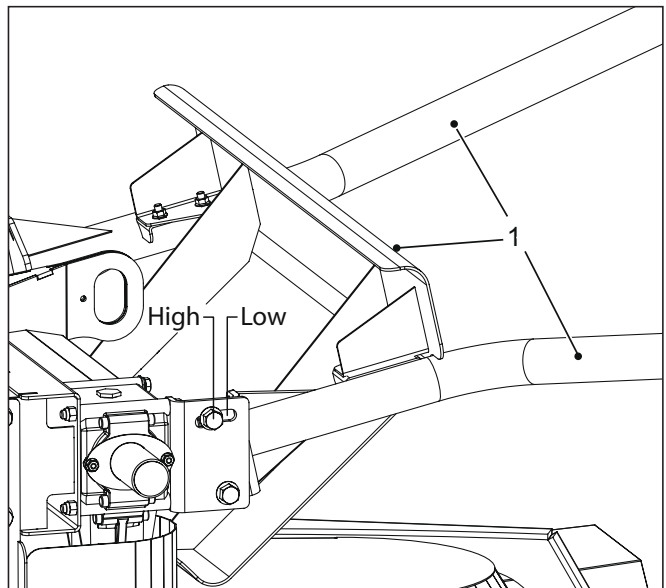

Figure 50 Deflectors (upper position)

FRICITION DISKS REPLACEMENT**FIGURE 51**

The friction clutch protects the machine against overloads and reduces the load at start-up. It includes two friction disks which are under a calibrated pressure. They are not adjustable and require no maintenance. In the case of frequent jams and overheated disks, or if they need to be replaced for any other reasons, the clutch will first need to be taken apart.

To replace a disk:

1. Tighten nuts (item 7) to remove pressure on the disk plates (items 5 & 6)
2. Using a hammer and a punch, unfold the tabs (on item 1). These tabs are holding the spring plates in place (item 2).

3. Remove the spring plates, the hub (item 3) and the two friction disks (item 2).
4. Clean the friction surfaces on the hub and the housing (items 1 and 3).
5. Assemble back in the same order and push in the tabs to hold the spring plates in place.
6. Loosen the nuts.

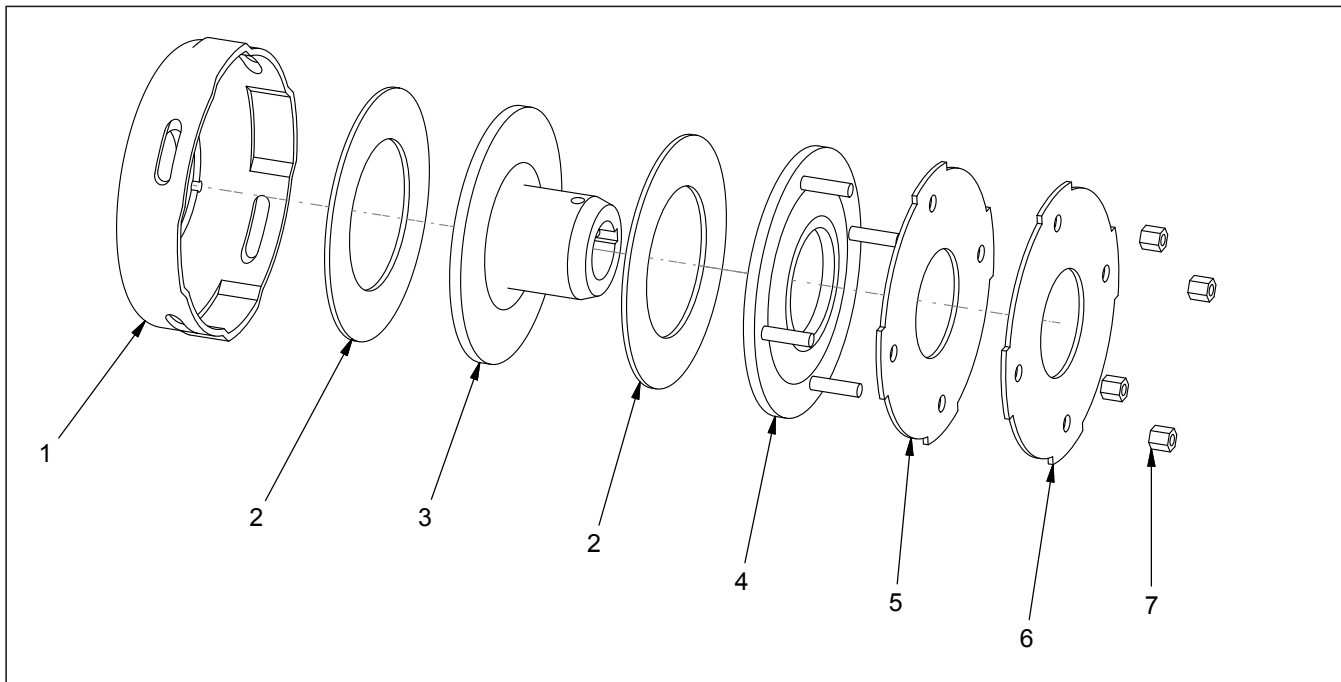

Figure 51 Friction disks replacement

DRIVE BELT REPLACEMENT - FIGURE 52

Follow these instructions to replace the drive belts:

1. Remove the bolted guard.
2. Unhook the spring (item 1 in figure 52).
3. Remove the tightener (item 2 in figure 52) if needed.
4. Mark the alignment of the couplers to keep chain synchronised, then remove chains.
5. Remove both belts and install new ones by sliding them between the coupler sprocket. Move the couplers away from each other if necessary.
6. Readjust the tightener stopper - 1/16" to 1/8" (1.5 to 3 mm) between the stopper (item 3 in figure 49) and the tightener (item 2 in figure 52).
7. Put guard back on.
3. Position drums to obtain 1/8" (3 mm) between the front scraper finger (item 4 in figure 55) and the drum edge (item 5 in figure 55).
4. Move drum to get approximately 1/4" (6 mm) between the rear scraper finger and the drum (figure 55).
5. Slightly tighten the bearing support plate bolts then remove the blocks. Holes in the frame allow for a minor drum adjustment, if needed.
6. Center the drum fingers between the scraper slots by moving the drum bearing. Loosen bolts (item 6, figure 56) to move the bearing,
7. Tighten the bearing bolts.
8. Turn the drum a full rotation to make sure it runs smoothly.

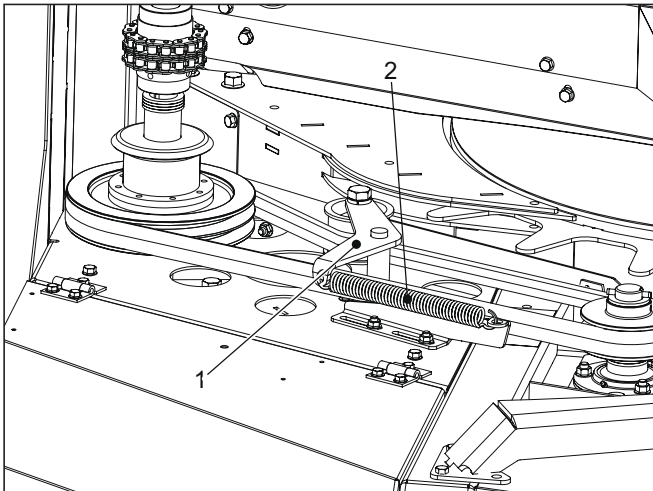

Figure 52 Belt tightener

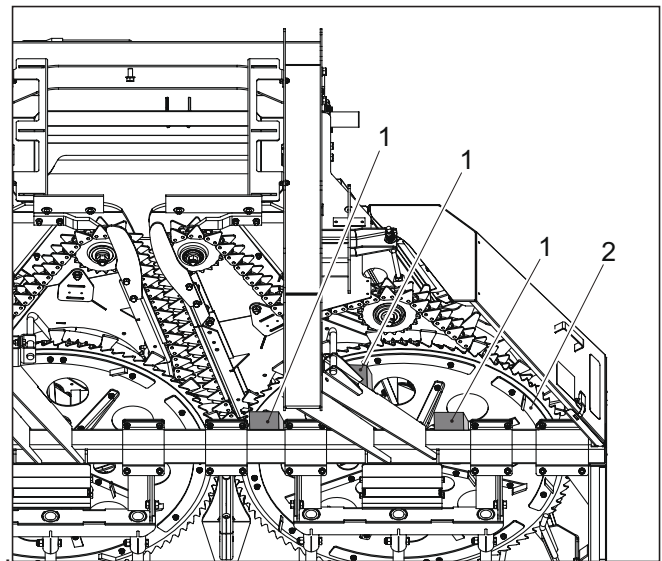

Figure 53

DRUM ADJUSTMENT - FIGURES 53 TO 56

The two drums are factory adjusted and do not need adjustment, except in the case of repair (bearing replacement). An alignment may be necessary to center the drum fingers (item 5 in figure 55) between the scraper plates (item 4 in figure 55).

To adjust:

1. Position the 1 1/2" (38 mm) blocks (items 1, figure 54) between the frame and the cutting disk, aligned with the knife sections (item 2). Position two blocks on the square cross beam and one on the frame's main beam.
2. Position a 1 1/4" (32 mm) block (item 3 in figure 54) between the disk and the lower drum fingers, aligned with the other blocks. The two drums should now be parallel.

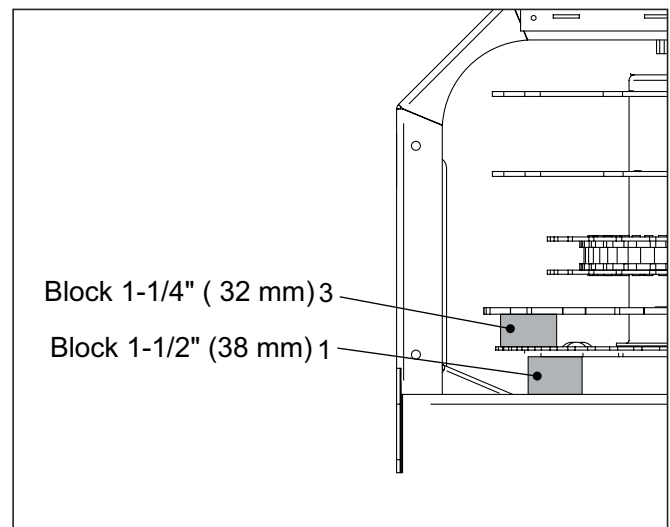

Figure 54 Drum adjustment

ADJUSTMENTS

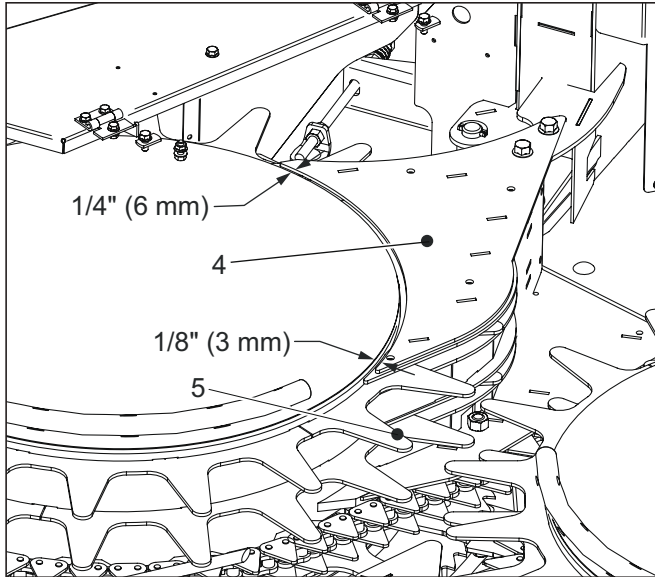

Figure 55 Drum adjustment

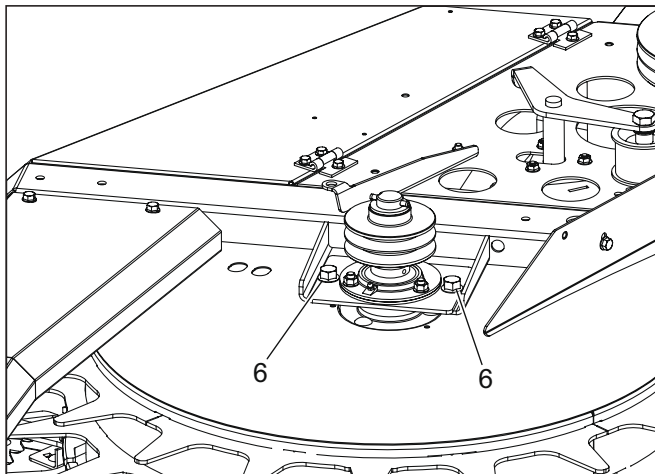

Figure 56 Drum support bearing bolts

SCRAPER ADJUSTMENT - FIGURE 57

It may be necessary to adjust the scrapers after they have been moved or replaced.

1. Remove the drums.
2. Loosen the scraper bolts.
3. Align the chain channel ridge with the frame ridge (figure 57).
4. Position the scraper to obtain 6 1/4" (160 mm) between the cross beam and the bottom of the scraper's lower plate (figure 57).
5. The holes in the frame allow for a minor scraper adjustment.
6. Tighten all bolts back then check alignment and position.
7. Reinstall the drums by following the drum adjustment instructions.

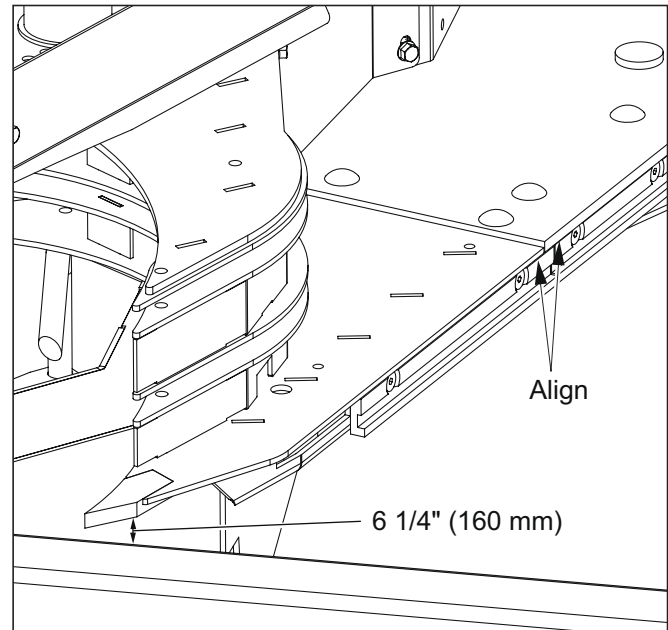

Figure 57 Scraper adjustment

MAINTENANCE SUMMARY

	First hour of operation	Every 8 hours or daily	Every 40 hours or at the end of season
Conveyor chain tension adjustment	X	X	X
Driving chain tension adjustment	X		X
Greasing - Chain tighteners (2 places)		X	
Cleaning and removing accumulated debris		X	X
Chain and tightener rod lubrication		X	
Gear box oil level verification	X		X
Overrunning clutch lubrication	X		X
Greasing - drum bearings (8 places)			X
Belt verification			X
Chain stretch verification			X
Cutting disks bolt verification			X
Knife verification		X	
Deflector knives verification		X	

IMPORTANT: An adequate maintenance and storage is essential to ensure the machine durability. They should never be neglected.

At the end of the season, we would suggest the following procedures:

1. Clean out the rotary attachment of all dirt, earth, material, excess of grease, or any other foreign substance which may absorb water thus causing rust.

NOTE: Never use a power washer to clean conveyor chains, bearings and gears.

2. Completely lubricate the attachment.
3. Run the machine a few minutes then check components. Make sure no bolts are loose or missing, particularly under the disks.
4. Lubricate the conveyor-chains with the recommended oil (part #F61-26340P).
5. Remove belt tension.
6. Clean and oil all components which have been exposed to wear.
7. Paint damaged parts.
8. Order parts that need to be replaced, and repair your attachment before starting a new season.
9. For your own safety, replace all damaged guards and not easily readable decals.
10. Store the attachment in a clean and dry location.

Problem: Excessive amount of corn ears on the ground

Causes: Dry conditions
Corn variety with ears of corn not holding strongly to the plant

Solutions: Raise the deflector tubes higher than the ears of corn
Install the support channel (see figure below) for dry conditions supplied with the adaptor kit.

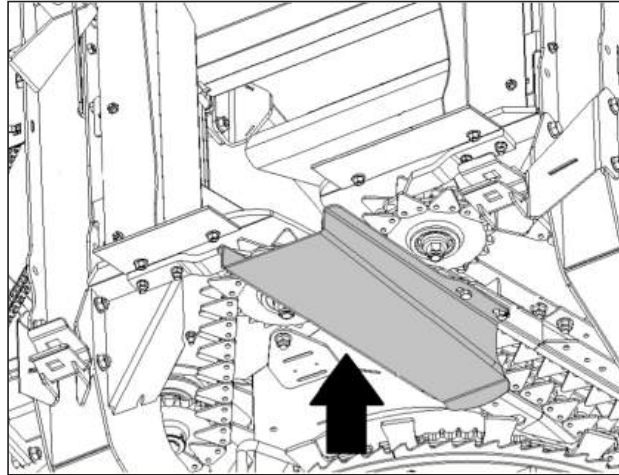

Lower the attachment so that the drums come in contact with the plant, under the ear of the corn.
Increase the forward speed.

Problem: Stem tips left on the ground

Causes: The plants are not held properly between the drum fingers and the base is cut twice.
Low corn population

Solutions: Adjust les deflector tubes parallel to the ground
Increase the forward speed
Avoid aligning the corn rows too close to the outside fingers
Make sure the front fingers are not bent or damaged

Problem: Complete or frequent stop

Causes: Disks or chain is jamming which makes the clutch slip
Clutch disks are worn

Solutions: Clear the disks or the chain
Verify and adjust chain tension
Reduce forward speed in down corn conditions
Replace the disks on the friction clutch

Problem: Disk jamming

Causes: Cleaning components are worn or out of adjustment
Debris are not being thrown by the cutter disks
Large amount of weeds

Solutions: Verify condition of cleaners and debris-plow under the disk. Replace if necessary.
Adjust the cleaning forks (See Adjustment section)

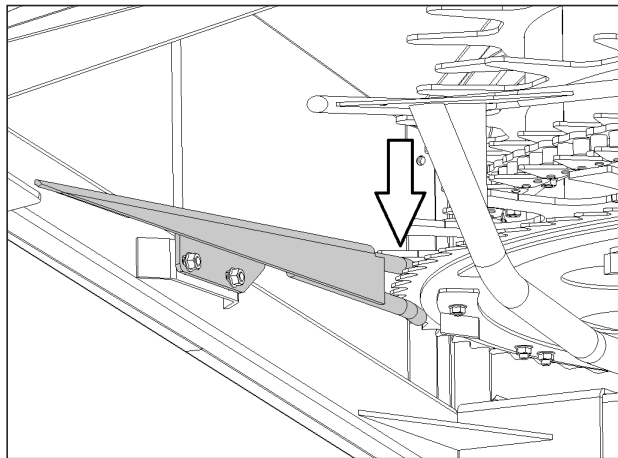

Maintain PTO speed to 1000 rpm minimum
Verify belt condition and spring adjustment

Problem: Jamming or lost of down corn

Causes: Tangled plants on the outside fingers
Jamming between chains

Solutions: Remove the small outside tip to improve the flow of plants
Drive diagonally from laying direction of stalks
Order and install a hydraulic rotary lifter kit (#K26898 – Single right hand side or #K26971 Dual side lifter kit)