

USE AND MAINTENANCE MANUAL

LIGHT FLAIL MOWER GINGER



PREFACE

This manual is an integral part of the machine.

It must always accompany the machine and be kept within reach of the operator.
The enclosures mentioned are an integral part of this manual.

The purpose of this manual.

This manual gives information for the correct and safe use of the machine.
The owner must read this manual carefully before work with the machine.

Responsibility of the owner

The owner is responsible for accidents or damages caused to people or things due to negligence in following the instructions in this manual.

Assistance in using this manual.

Explanations: contact the dealer.

Request for additional copies of the manual: in case of loss or wear and tear, or in case one wants the manual in a different language, the customer should ask the dealer or manufacturer.

Pay attention to the warning signals.



<Danger>: indicates a situation that is potentially dangerous which, if not avoided, will cause death or serious damage.



<Warning>: indicates a situation that is potentially dangerous which, if not avoided, will cause death or serious damage.



<Caution>: indicates a situation that is potentially dangerous which, if not avoided, can cause minor to moderate damage, or it indicates to be careful about an unsafe procedure.

<Important>: indicates instructions that must be followed precisely in order to avoid damage to the product, process or environment.

<Note>: indicates supplementary information.

DESCRIPTION

FUNCTION OF USE

The machine, thanks to the three-point hitch, can perform different functions such as grass cutting, stalk chopping, pruning etc depending on the mounted tools.

The use of a technical construction concept aimed at the pursuit of high performance, reliability and durability improves and optimizes the power/consumption ratio of the tractor due to the rigidity of the machine frame, the shape of the tools, the perfect dynamic balance of the rotor and many other original technical solutions.

PERFORMANCE

The machine is connected to the tractor by a three-point hitch that provides translatory motion and a universal PTO-shaft connected to the tractor's PTO that provides rotary motion to the rotor.

The working width is fixed and determined by the type of machine.

The cutting height is adjustable.

The working area is centered with respect to the longitudinal axis of the tractor.

The rear roller, in addition to performing the function of cutting height adjustment, also compacts the cut material.

PERFORMANCE LIMITS

- ❑ Maximum forward speed: 5 km/h (3 m/h). Speeds higher than indicated may compromise machine integrity, work quality and operator safety.
- ❑ Max power applicable to the gearbox: 9 to 20 Kw 5% to 540 rpm depending on type. Higher powers than indicated can irreparably damage the gearbox, especially if heavy-duty work is performed.

STANDARD FEATURES

- **PTO-shaft.**
- **Free-wheel device in the gearbox.**
- **Rear roller.**
- **Y-blades.**
- **Aluminium gearbox.**

OPTIONS & ACCESSORIES

- **Hammers.**
- **Kit quick hitch.**

TECHNICAL FEATURES

FEATURES BY MODEL

Model	Type	Version	Power		Working width		Weight		Dimensions A x B x H	Tools n.	Rotor revolutions
			Hp	Kw	cm	Inch	kg	lbs	Cm	n°	RPM
GINGER	80	C	12-28	9-20	80	32	104	229	-	24	2410
	96	C	12-28	9-20	96	38	105	231	-	32	2410
	106	C	12-28	9-20	106	42	113	249	-	32	2410
	125	C	12-28	9-20	125	50	114	251	-	40	2410
	80	M	12-28	9-20	80	32	104	229	-	12	2410
	96	M	12-28	9-20	96	38	105	231	-	16	2410
	106	M	12-28	9-20	106	42	113	249	-	16	2410
	125	M	12-28	9-20	125	50	114	251	-	20	2410

Version:

C = Y-blades

M = Hammers

GENERAL PRESCRIPTIONS

- ❑ Work only in daylight.
- ❑ To prevent damage caused by objects thrown by the blades or fragments of the blades themselves, make sure there are no people or animals within at least 50 meters of the machine before starting work.
- ❑ Wear long pants and sturdy shoes.
- ❑ Guards are an integral part of the machine: always work with guards.
- ❑ Pay attention to the ground surface: there should be no stones, sticks, wires, etc...
- ❑ Beware of use on a slope: proceed in the direction of maximum slope and never at an angle.
- ❑ Before leaving the driver's seat, turn off the engine and disconnect the engine-shaft transmission.
- ❑ Immediately check the machine in case foreign bodies are touched.
- ❑ Immediately check the machine in case of unusually strong vibrations.
- ❑ Promptly change defective parts.

❑ **CAUTION - WARNING:**

The gearbox is equipped with a freewheeling device, after disconnecting the PTO the rotor continues to turn for at least 30 seconds, before approaching the cutting organs make sure the rotor is stopped.

❑ **ATTENTION:**

To avoid breakage of the PTO-shaft and gearbox, do not start the machine abruptly.

SAFETY RESTRICTIONS

Children and persons unfamiliar with these instructions should not be allowed to use the machine. Local prescriptions may restrict the use of the machine based on age.

RUNNING IN

The new machine must be run in. When first used, attach the machine to the tractor, connect the PTO shaft, lower the machine six inches off the ground then start the PTO and gradually reach 540 rpm. Run the machine for about 15 minutes. Any hissing in the media area is normal and is due to the settling of the protective guards; it will disappear in a short time. After the first 30 minutes of operation, check the tension of the belts.

SAFETY SIGNS ON THE MACHINE

This section reproduces and explains the safety signs on the machine.



1

2

3

4

5

6

1. Read the operator's manual
2. Disconnect the tractor control panel key before servicing or repairing.
3. Do not remove guards.
4. Keep a distance from the cardan shaft.
5. Keep away; possible throwing of objects.
6. Keep distance from knives.

Safety signs on the machine must remain clearly legible.

In case of damage, the warning labels must be replaced.

If machine parts bearing warning labels are replaced, they must be restored.

Provision of new warning labels and application procedure

To obtain new warning labels, with instructions on their application, contact your dealer.

CARDAN SHAFT LENGTH CHECKING

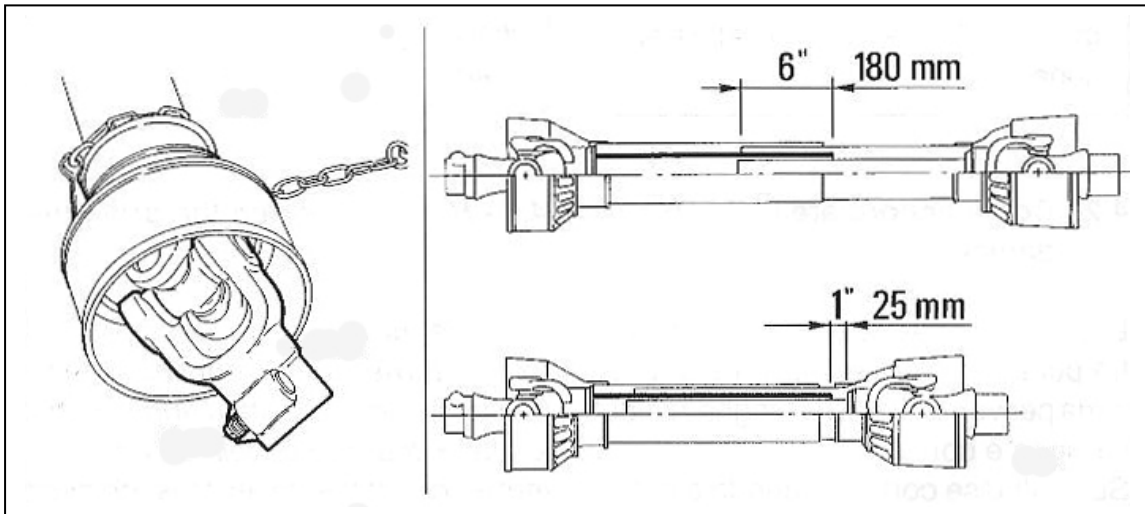

1. After having linked up the machine to the third point, please check it is placed in a horizontal and central position in relation to the tractor using the adjustment devices.
2. Place the PTO shaft between the tractor's PTO and the machine's PTO.
3. Check the length of the PTO shaft.
4. The length of the PTO shaft is correct if in the working position the minimum length of the coupling between the inner tube and the outer tube is not less than 180 mm and if, at the same time, in the condition of minimum extension, the PTO shaft still can make a movement of 25 mm.
5. If the minimum coupling length is less than 180 mm, it means that the PTO shaft is too short and you will need to replace it with a longer one.
6. If in condition of minimum extension the PTO can run less than 25 mm, it is too long and it must be shortened.
7. **WARNING:** shortening a PTO shaft is quite complicated. Always read the instructions contained in the following chapter before starting this delicate procedure not to damage the PTO shaft.

HOW TO SHORTEN THE CARDAN SHAFT

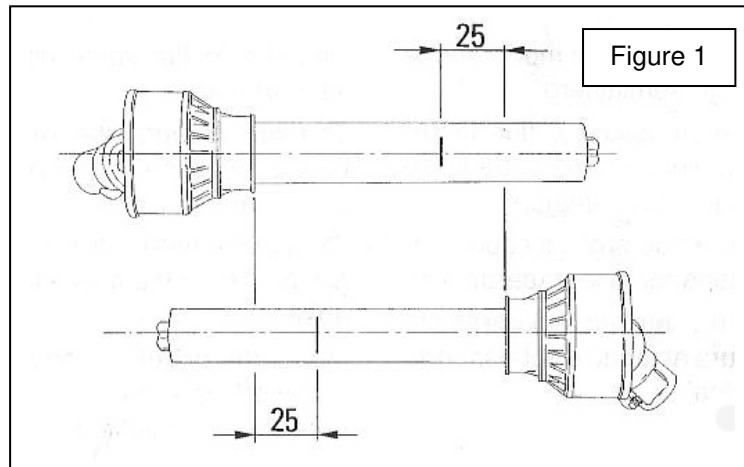

1. Move the machine as close as possible to the tractor, by using a hydraulic lift.
2. Once in this position, stop the hydraulic lift and switch the engine off.
3. Separate the two parts of the PTO shaft.
4. Insert the "female" PTO shaft (that is to say the larger-diameter tube) in the tractor's PTO.
5. Insert the "male" PTO shaft (that is to say the smaller-diameter tube) in the machine's PTO.
6. Place each part of the PTO shaft parallel to the other. Then, use a permanent marker to highlight the cutting point as shown in the figure "1".

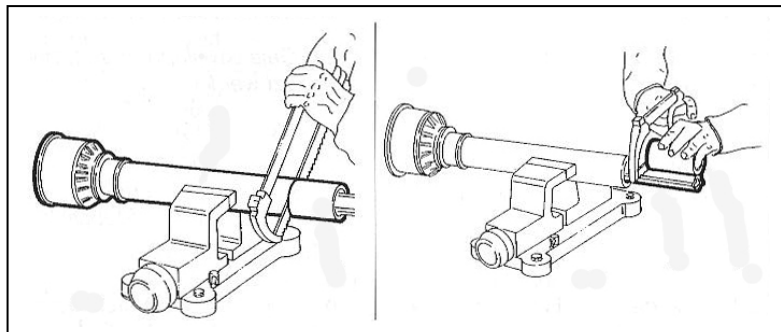

1. Use a bow saw to cut the plastic tube on the marker line that you had already drawn on one of the PTO shaft parts.
2. Align the part of the tube that you have already cut at the bottom of and cut it.
3. Repeat the same operations on the second part of the PTO shaft.
4. Use a file to bevel the extremities of the tubes.
5. Clean and grease the two metallic tubes and insert the first part of the PTO shaft inside the other.
6. Set up the PTO shaft between the tractor and the machine and check its length another time.

1. BEFORE STARTING WORK

(a) Hitch the machine to the tractor by proceeding as follows:

1. Remove the safety snap cotter pins from the two lower attachment pins of the machine.
2. Insert the lifting arms of the tractor into the lower hitch pins of the machine, the safety snap cotter pins.
3. Connect via the tie rod the three-point hitch of the tractor to the three-point hitch of the machine (vertex of the attachment triangle), reinsert the pin and lock with the snap cotter pin.

a) With the machine raised, move to the working area.

b) Connect the tractor's PTO to the machine's PTO shaft.

c) Verify that the gimbal chain is secured to prevent rotation of the gimbal protection sheath.

d) Adjust the cutting height by acting as follows:

1. Lower the machine until the rear roller touches the ground.
2. Lengthen the third-point linkage to increase the cutting height, shorten it to decrease it.
3. After adjusting, make sure you have tightened the lock nut on the tie rod.

2. START WORKING

a) Make sure there is no person within a radius of 50 m all around the machine.

b) Engage the PTO and gradually reach the intended speed of rotation.

c) Lower the machine until the rear roller rests on the ground.

d) Start working.

3. END OF WORK

a) Stop the tractor and wait for at least 30 seconds for the rotor to have time to stop.

b) Lift the machine off the ground.

c) Disconnect the PTO.

d) Disconnect the PTO shaft from the tractor's PTO.

e) Raise the machine completely.

MAINTENANCE INSTRUCTIONS

Tab "A" shows the maintenance with the corresponding due dates to be performed on the machine. Failure to meet the scheduled deadlines will impair the proper operation of the machine and void the warranty.

TAB "A" SCHEDULED MAINTENANCE

	FIRST START	AFTER 10 H.	EVERY 30 H.	EVERY 500 H.	END OF SEASON	START WORKING	END OF WORK
MACHINE	Greasing		Greasing		Cleaning Greasing		Cleaning
GEARBOX	Oil level	Filling up	Oil level	Change oil			
SCREWS		Tightening	Tightening				
TOOLS			Check		Check	Check	Check
BELT		Check tension		Replace			

1. GREASING

As specified in tab "A", grease points "B", "C", "D", "E", "F", "G".

The greasing points are equipped with grease gun TYPE HYDRAULIC FORMAT "A" UNI 7663.

Use only LITHIUM-BASED MULTIFUNCTIONAL GREASE Type NLGI 2 for greasing.

2. OIL LEVEL - ALUMINUM GEARBOX OIL CHANGE

At the intervals specified in sheet "A" check the level or replace the oil in the gearbox.

Use only SAE 90 OIL for topping up.

Gearbox capacity: 0.5 L.

a) To check the oil level in the gearbox, proceed as follows:

1. With the machine level, unscrew plug "A" and check the oil level grazes the edge of the hole.
2. If the level is okay, screw cap "A" back on tightly.
3. If the level is low, top up.
4. When the level is reached, screw cap "A" back on tightly.

b) To replace the oil in the gearbox, proceed as follows:

1. Unscrew cap "A", tilt the machine to one side and wait until all the oil has drained out.
2. Introduce new oil from plug "A".
3. When the level is reached, screw cap "A" back on tightly.

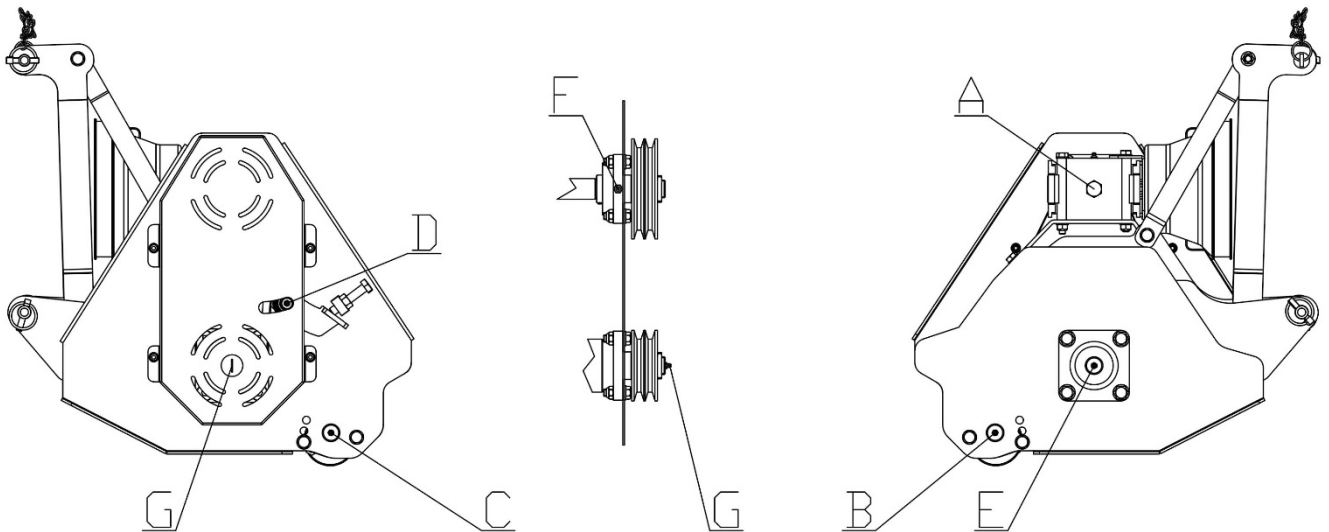

3. TOOLS REPLACEMENT

a) To replace the tools, proceed as follows:

1. Unscrew the nut and slide out the fixing screw "B".
2. Slide out the blades "A" with their bushings or mace "A".
3. Position the new tool.
4. Insert screw "B" and lock the nut.
5. CAUTION: All tools must be of the same type.
6. CAUTION: If the type of tool is changed, the rotor must be rebalanced.

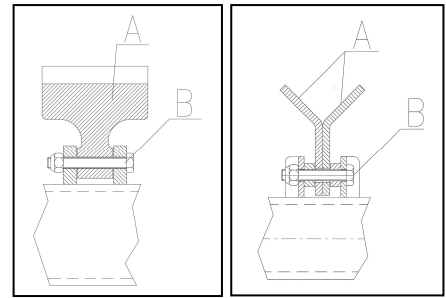

4. ADJUSTMENT AND REPLACEMENT OF TRANSMISSION BELTS

a) To adjust the tension of transmission belts, proceed as follows:

1. Remove the carter "E" by unscrewing the four screws "D".
2. Unscrew lock nut "A", screw screw "B" to tension the belts or unscrew it to loosen them. The belt tension is correct when the belts flex about 1/8" - 1/4" when pushing them on the side opposite of the belt tensioner.
3. After the adjustment is done, screw the lock nut "A" back on and reassemble the carter "E".

b) To replace transmission belts, proceed as follows:

1. Remove the carter "E" by unscrewing the four screws "D".
2. Unscrew the lock nut "A" and completely unscrew the adjusting screw "B".
3. Dismantle the two worn belts "C", to avoid adjustment problems they must both be replaced, mount the new belts.
4. Perform steps "2" and "3" of step "a".
5. CAUTION: After the first 30 minutes of operation, recheck the tension of the belts.

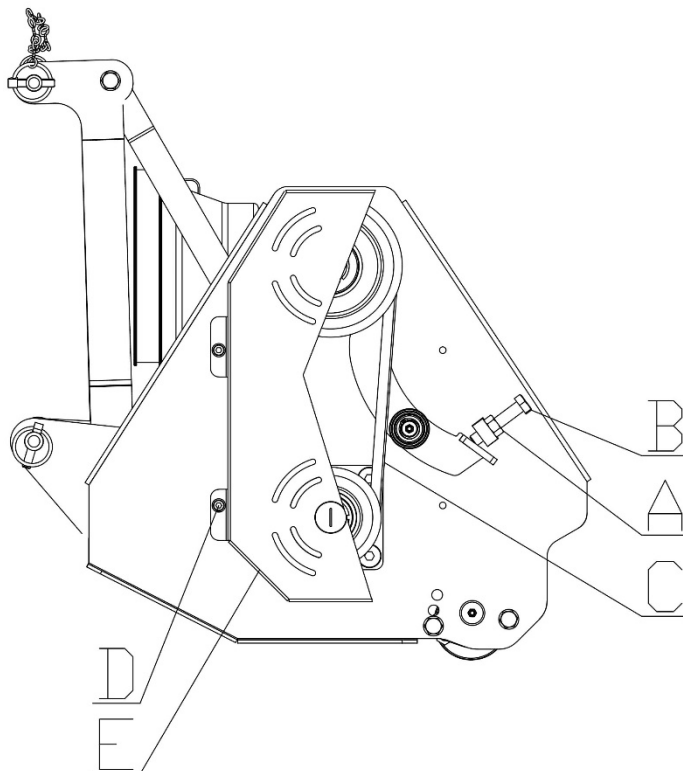

5. QUICK HITCH KIT ASSEMBLING

The machine is shipped with the standard hitch suitable for tractors with category I 3-point hydraulic lift, a "quick hitch kit" is supplied with the machine to make the hitch suitable for tractors equipped with a "Quick Attaching Coupler".

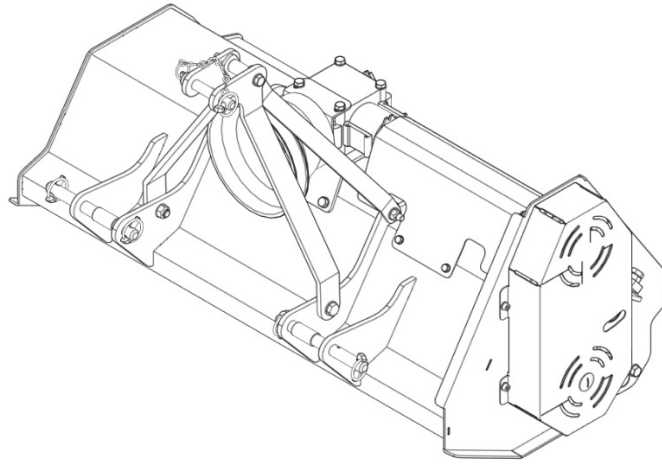

Standard Attachment

To mount the quick hitch kit, proceed as follows:

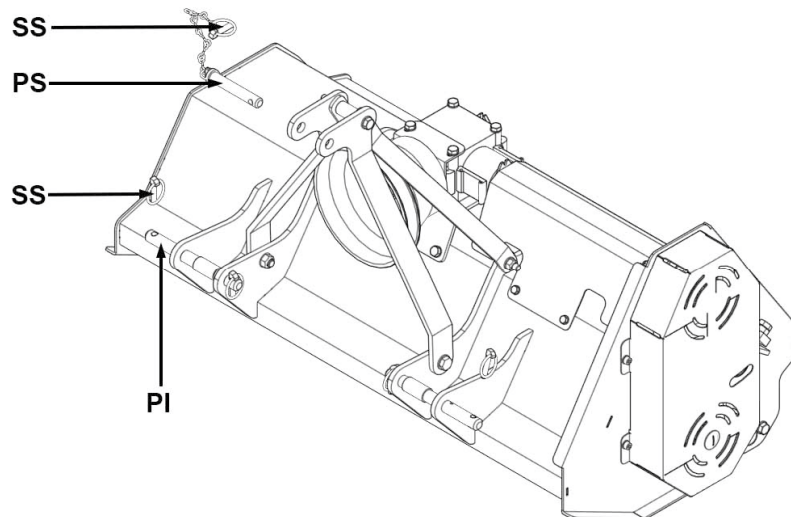

1. Remove the SS safety pin from the lower "PI" pins,
2. Remove the upper pin "PS" from the third point after removing the safety pin "SS".

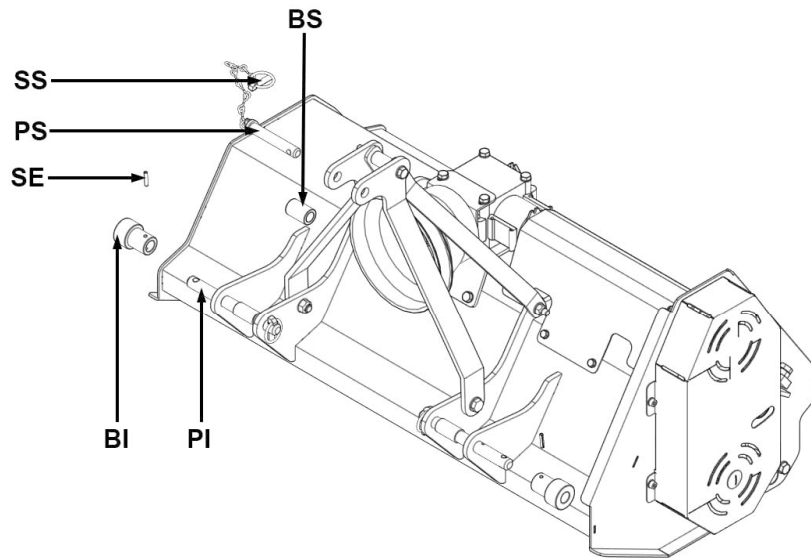

1. Insert the bushing "BI" onto the lower right pin "PI" and then lock it with the spring pin "SE".
2. Repeat step 1 with the left lower pin "PI".
3. Insert the bushing "BS" in the III° point then insert the pin "PS" and lock it with the safety pin "SS".

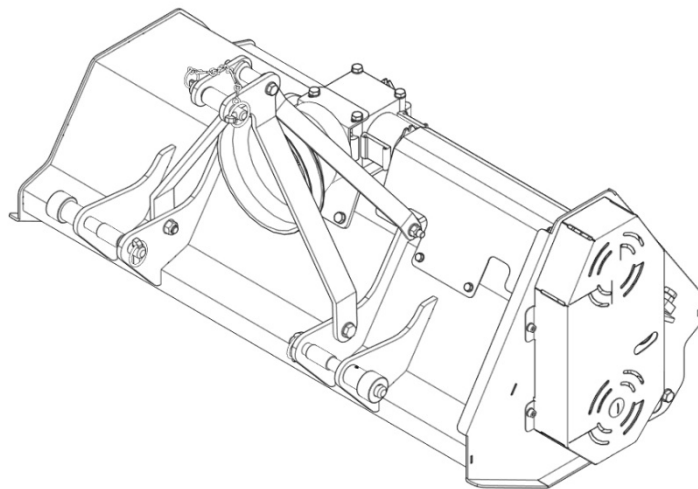

Quick Hitch Attack

TROUBLESHOOTING

PROBLEMS	REASONS AND SOLUTIONS
Abnormal vibration	-Unbalanced rotor - Contact service center. -Loss of one or more tools - Replace them. -Worn bearings - Replace them.
Irregular or unsatisfactory cutting	-Worn tools - Replace them. -Not optimal tool selection - Replace them with other type.

TRANSPORT

Except when working, moving the machine takes place when the machine is standing still and the transmission is disconnected.

<Important>: keep speed low avoiding holes and ground roughness.

<Important>: Before begin the movements always make sure that the safety hooks be in position.

<Note when on the road>, obey existing traffic laws. Exhibit the signal signs on the rear ends. Respect any local laws there may be.

STORAGE

Store the machine in a dry place that isn't dusty.

INFORMATION ON DEMOLITION



At the end of its working life, the machine must be sent to be demolished and that can only be done by an authorized authority, in accordance with the national laws in force for the environment. Therefore it is necessary to get information from the qualified local authorities on the procedure to follow. The machine is mainly composed of: iron materials and paints.

WARRANTY

The machine is covered by the manufacturer warranty for a period of 24 months.

The warranty is not applicable when:

- a) The maintenance work has not been done correctly.
- b) The machine has been used out of its own service.
- c) The machine has been transformed or modified without the manufacturer's written authorization.

INDICE GENERALE

PREFACE	2
DESCRIPTION	3
FUNCTION OF USE.....	3
PERFORMANCE	3
PERFORMANCE LIMITS	3
STANDARD FEATURES.....	3
OPTIONS & ACCESSORIES.....	3
TECHNICAL FEATURES	4
SAFETY INFORMATION	5
GENERAL PRESCRIPTIONS	5
SAFETY RESTRICTIONS	5
RUNNING IN	5
SAFETY SIGNS ON THE MACHINE	6
CARDAN SHAFT LENGTH CHECKING	7
HOW TO SHORTEN THE CARDAN SHAFT	8
INSTRUCTIONS FOR USE	9
1. BEFORE STARTING WORK	9
2. START WORKING.....	9
3. END OF WORK.....	9
MAINTENANCE INSTRUCTIONS	10
TAB "A" SCHEDULED MAINTENANCE.....	10
1. GREASING	11
2. OIL LEVEL - ALUMINUM GEARBOX OIL CHANGE.....	11
3. TOOLS REPLACEMENT	12
4. ADJUSTMENT AND REPLACEMENT OF TRANSMISSION BELTS.....	12
5. QUICK HITCH KIT ASSEMBLING	13
TROUBLESHOOTING	15
TRANSPORT	16
STORAGE	16
INFORMATION ON DEMOLITION	16
WARRANTY	16
WORK AND MAINTENANCE SHEET	17