

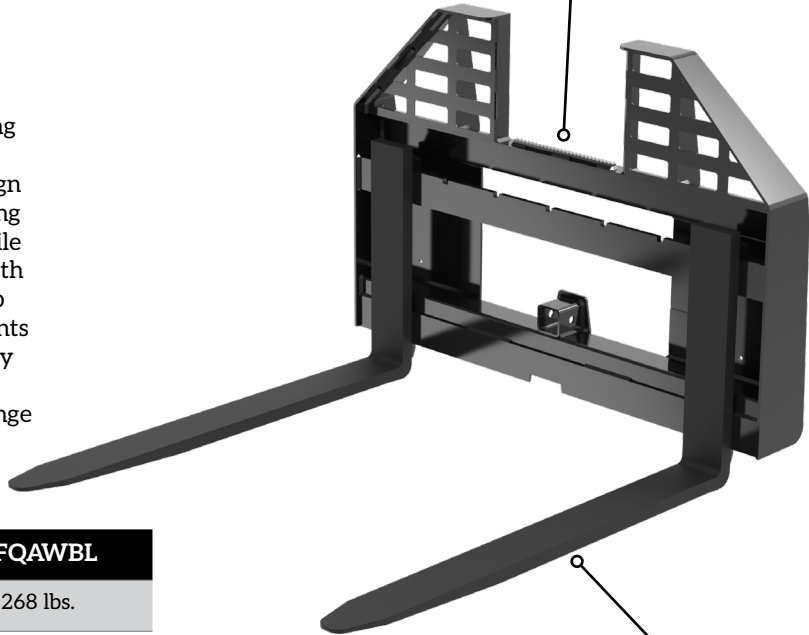

WALK-THRU PALLET FORKS

Introducing our Walk-Thru Pallet Forks, featuring a hassle-free step-through design optimized specifically for skid-steer loaders. The open design also enhances visibility during operation, allowing you to maneuver confidently in tight spaces while maintaining a clear line of sight to your load. With the universal quick-attach system, you can swap between these pallet forks with other attachments in seconds, maximizing your machine's versatility on the job site. Engineered for durability and performance, they're ready to tackle any challenge you throw at them.

Step-Through Design
A must-have for skid-steer operators.



Multi-Position Locking Forks
Remove the forks to utilize the 2" receiver.



MODEL	PFQA12WBL	PFQAWBL
Weight (lb)	238 lbs.	268 lbs.
Lift Capacity (lb)	1200 lbs. at 19" load center	3000 lbs. at 19" load center
Hitch	Universal Quick-Attach	
Height, Overall (in.)	34"	
Width, Overall (in.)	46"	
Length, Overall (in.)	49"	
Fork Length (in.)	42"	