

Haymaking | Fenaïson

WHEEL RAKES RATEAUX SOLEIL



AGRICULTURAL MACHINERY
enorossi

www.enorossi.it

ENG-FRA



Low energy consumption
Faible consommation d'énergie

The wheel rake is the most efficient machine in uneven ground conditions, ensuring the cleanest product possible. It works by towing, therefore not using the PTO power take-off, it significantly reduces costs for the farmer and the environmental impact. This feature, together with the low maintenance cost, makes this type of rake, with the same working width, the most convenient solution for the farmer.

Le râteau andaineur soleil est la machine la plus efficace dans les conditions de sol inégales, garantissant le produit le plus propre possible. Il fonctionne par remorquage, donc n'utilisant pas la prise de force il réduit considérablement les coûts pour l'agriculteur et l'impact environnemental. Cette caractéristique, associée au faible coût d'entretien, fait de ce type de râteau, à largeur de travail égal, la solution la plus pratique pour l'agriculteur.

WHEEL RAKES RATEAUX SOLEIL

Frame in "line" / *Châssis en ligne*

RP

RT

"V" frame with central joint / *Châssis en "V" avec joint central*

CADDY

BATRAKE

MAXIMUS

"V" frame with rear joint / *Châssis en "V" avec joint arrière*

EASY RAKE

EASY RAKE SUPERSTAR

Your ideas, Our products

Enorossi has a wide range of wheel rakes, ideal for any farmer's need.

The rake wheels, with different systems, adapt individually and perfectly to the ground, guaranteeing excellent work especially in difficult field conditions.

The versatility of the wheel rakes make them suitable for harvesting grass, straw, corn stalks, sorghum and sugar cane.

Enorossi propose une large gamme de râteaux soleil, idéaux pour tous les besoins des agriculteurs. Les soelils, avec différents systèmes, s'adaptent individuellement et parfaitement au sol assurant un excellent travail surtout dans des conditions de terrain difficiles. La polyvalence des râteaux soleil les rend adaptés à la récolte de l'herbe, de la paille, des tiges de maïs, du sorgho et de la canne à sucre.

MAIN FEATURES

CARACTÉRISTIQUES PRINCIPALES



The frame

Châssis



Frame inline
Châssis en ligne



"V" frame with central joint
Châssis en "V" avec joint central



"V" frame with rear joint
Châssis en "V" avec joint arrière



Windrow width adjustment

Réglage de la largeur d'andain

Each model of wheel rake has the possibility to adjust the width of the windrow width: single system (formation of one windrow) or double passage in the field (formation of two windrows side by side) for models with in-line frame; hydraulic system in V-frame models with central joint; mechanical system in V-models with rear joint.

Chaque modèle de râseau soleil a la possibilité de régler la largeur de l'andain avec : un système simple (formation d'un andain) ou double passage dans le champ (formation de deux andains côte à côte) pour les modèles avec châssis en ligne ; un système hydraulique dans les modèles à châssis en V avec joint central ; un système mécanique dans les modèles en V avec joint arrière.



Maximum working width (A)
till to 12,10 meters (models EASY
RAKE SUPERSTAR 22 SN ST).

Largeur de travail maximale (A)
jusqu'à 12,10 mètres (modèle
EASY RAKE SUPERSTAR 22 SN ST).

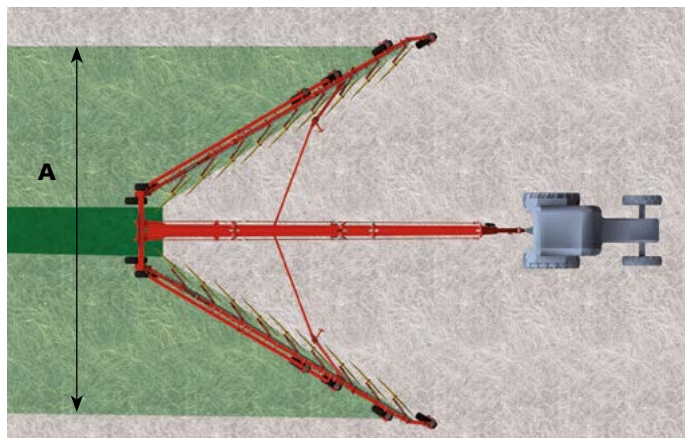



Rake wheels

Les soleils

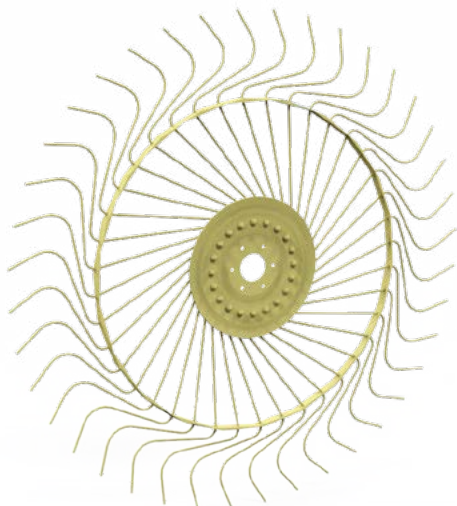

Standard rake wheel
Soleil standard

Standard rake wheel with 145 cm diameter and 6.9 mm diameter teeth for the models RP, RT, CADDY.
Standard rake wheel with 150 cm diameter and 7.5 mm diameter teeth for the models BATRAKE, MAXIMUS, EASY RAKE, EASY RAKE SUPERSTAR.

*Soleil standard avec diamètre de 145 cm et dents avec diamètre de 6,9 mm pour les modèles RP, RT, CADDY.
Soleil standard avec diamètre de 150 cm et dents avec diamètre de 7,5 mm pour les modèles BATRAKE, MAXIMUS, EASY RAKE, EASY RAKE SUPERSTAR.*

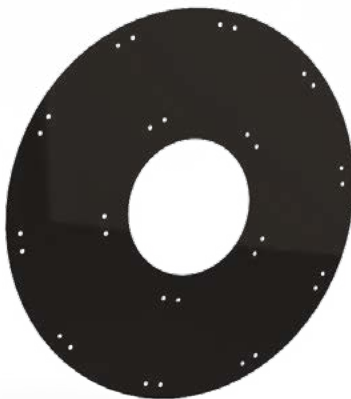

Wind guard
Disque ABS

The Wind guards facilitate the process of unloading the forage from the rake wheels, avoiding it sticking to them and also helps not to disperse the product in windy conditions.

Le disque ABS facilite le processus de déchargement du fourrage des soleils, l'empêchant de s'y coller. Il aide également à ne pas disperser le produit dans des conditions venteuses.



Rubberflex rake wheel
Roues Rubberflex

The Rubberflex wheel has been designed for heavy products and has the particularity of having short teeth and a very robust structure. With Rubberflex wheels it is also possible to increase the working speed. Available from model MAXIMUS, EASY RAKE, EASY RAKE SUPERSTAR.

La roue Rubberflex a été conçue pour les produits lourds et a la particularité d'avoir des dents courtes et une structure très robuste. Avec les roues Rubberflex, il est également possible d'augmenter la vitesse de travail. Disponible pour les modèles MAXIMUS, EASY RAKE et EASY RAKE SUPERSTAR.

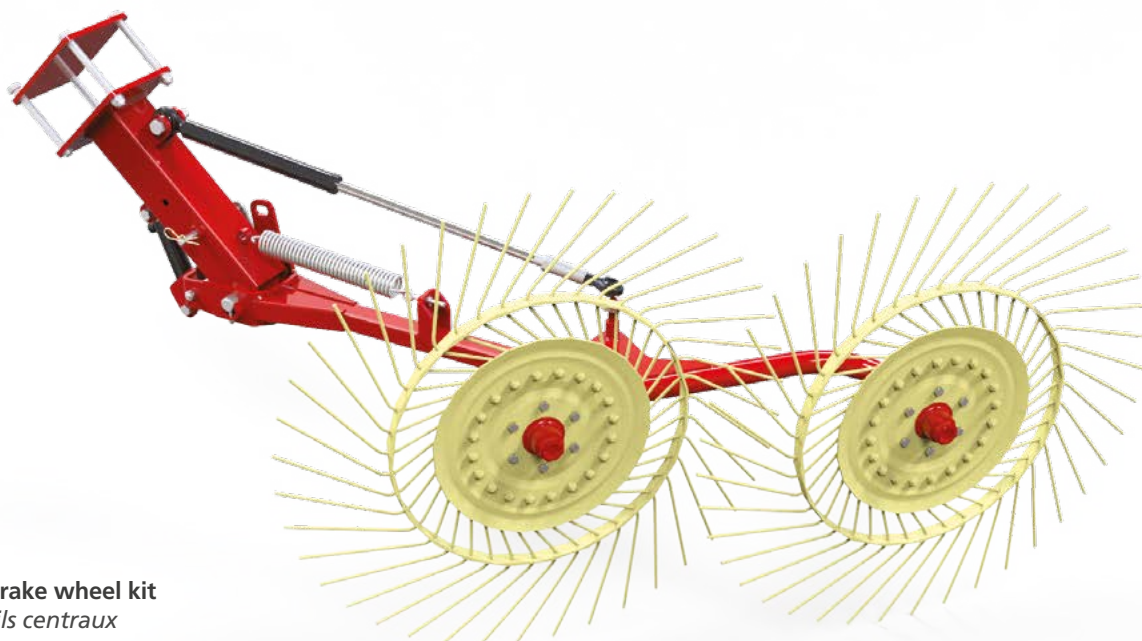

Central rake wheel kit
Kit soleils centraux

Available for the entire range of "V" rakes, they guarantee the turning of the product in correspondence with the windrow allowing better drying of the forage.

Disponibles pour toute la gamme des andaineurs en "V", ils garantissent le retournement du produit en correspondance avec l'andain permettant un meilleur séchage du fourrage.



MAIN FEATURES

CARACTÉRISTIQUES PRINCIPALES



Pressure regulation of the rake wheels on the ground *Régulation de la pression des soleils au sol*

It is possible to adjust the ground pressure of the rake wheels according to the quantity of the product and the quality of the ground.

Il est possible d'ajuster la pression des soleils au sol en fonction de la quantité de produit et de la qualité du sol.

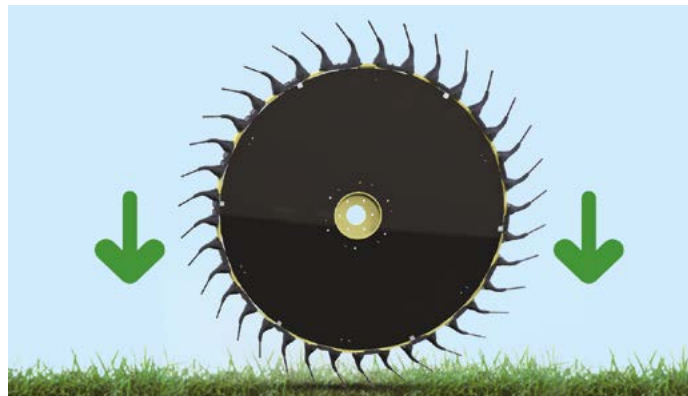

Ground adaptation of the rake wheels *Adaptation des soleils au sol*

The adaptation of the rake wheels to the ground is very important, especially in conditions of disconnected terrain, therefore each model of rake has its own adjustment system.

L'adaptation des soleils au sol est très importante surtout dans des conditions de sol déconnecté, donc chaque modèle de râteau à son propre système de régulation.

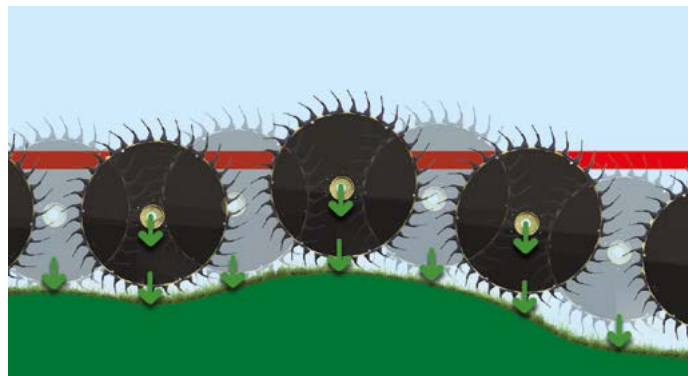

Hydraulic lifting of the rake wheels *Levage hydraulique des soleils*

This system allows to quickly switch from the work position to the transport position in a simple and fast way without getting off the tractor.

Ce système permet de passer rapidement de la position de travail à la position de transport de manière simple et rapide sans descendre du tracteur.



Rake wheel hub lubrication and tapered roller bearing *Lubrification du moyeu de soleil et roulement à rouleaux coniques*

The hub of the rake wheels is grease lubricated, with tapered roller bearings, and sealed.

Le moyeu des soleils est lubrifié à la graisse, avec des roulements à rouleaux coniques, et scellé.

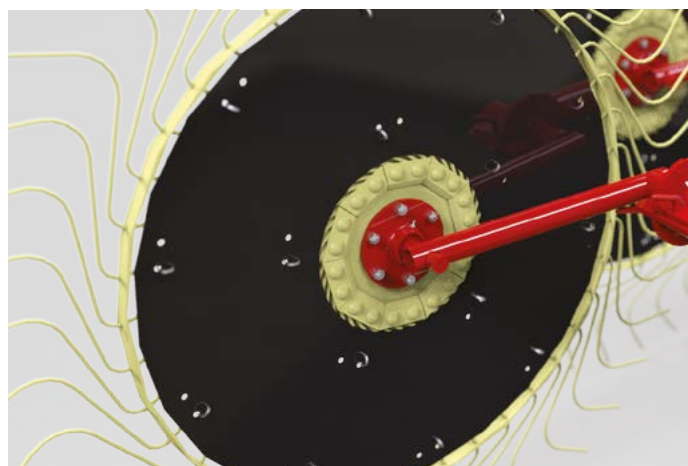



Maneuverability and comfort

Maniabilité et confort



Turn-fast system Système turn-fast

The automatic self-steering system allows the machine to perfectly follow the movements of the tractor both during the work phase and especially during transport.

Le système automatique auto-directionnel permet à la machine de suivre parfaitement les mouvements du tracteur pendant le travail et surtout pendant le transport.

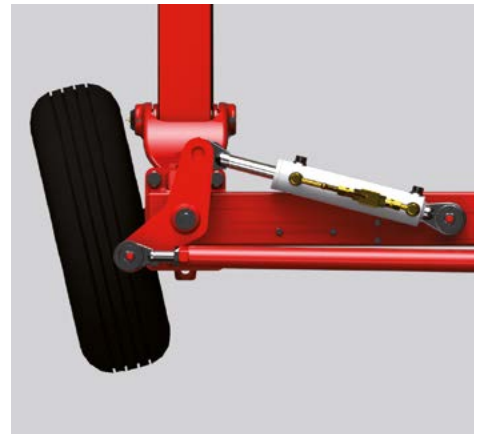

Cushioned pivoting wheel Roue pivotante avec amortisseur

The pivoting wheel with shock absorber allows the rake to adapt to all types of terrain by minimizing the stresses of the structure and increasing the forward speed in the field and on bumpy roads.

La roue pivotante avec amortisseur permet au râteau de s'adapter à tous les types de terrain en minimisant les contraintes de la structure et en augmentant la vitesse d'avancement dans le champ et sur routes accidentées.

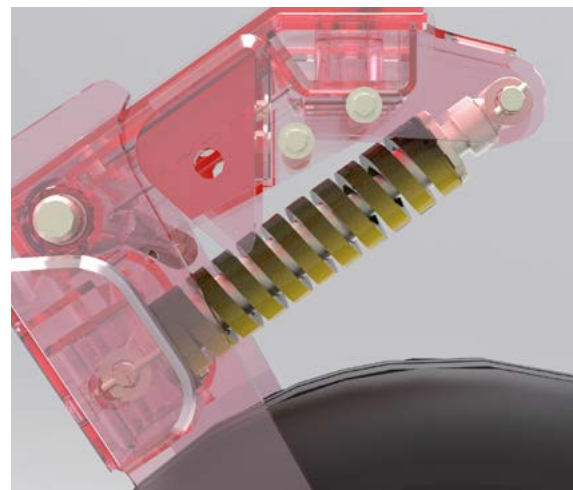

RP

Inline rake

Râteau soleil en ligne

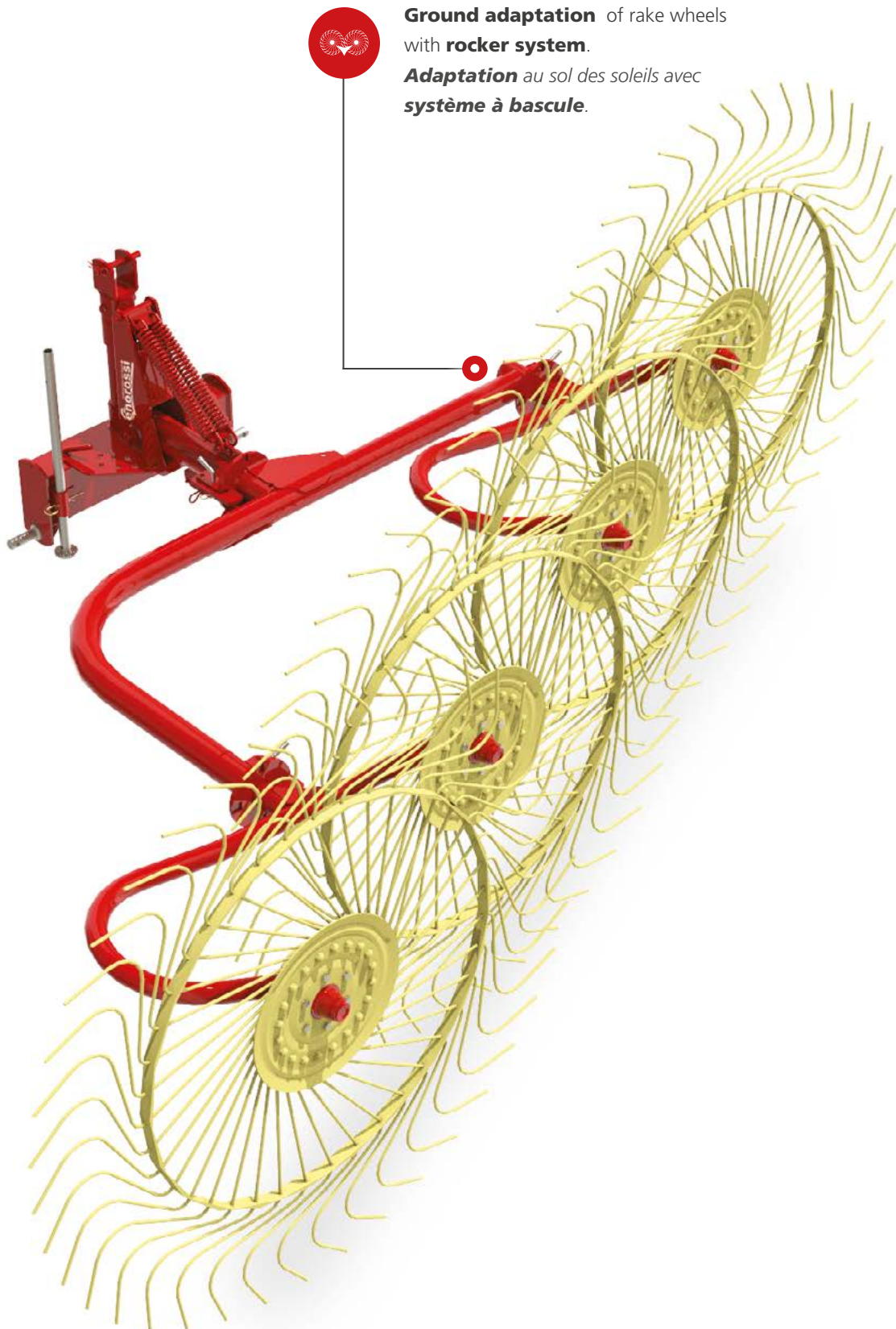

Ground adaptation of rake wheels with **rocker system**.

Adaptation au sol des soleils avec **système à bascule**.

RP rakes are ideal for small farmers. They are very simple and robust machines and require very little maintenance.

Les râteaux soleil RP sont idéaux pour les petits agriculteurs. Ce sont des machines très simples et robustes et nécessitent très peu d'entretien.

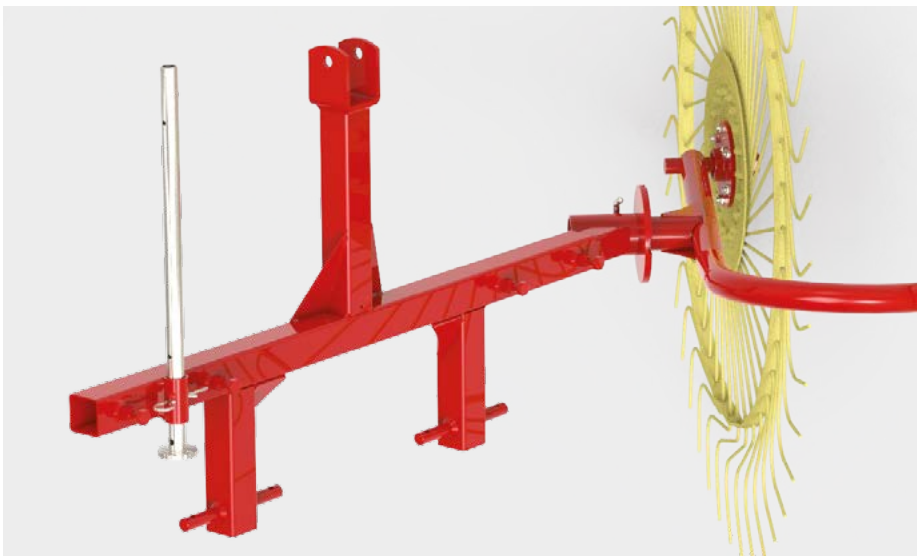
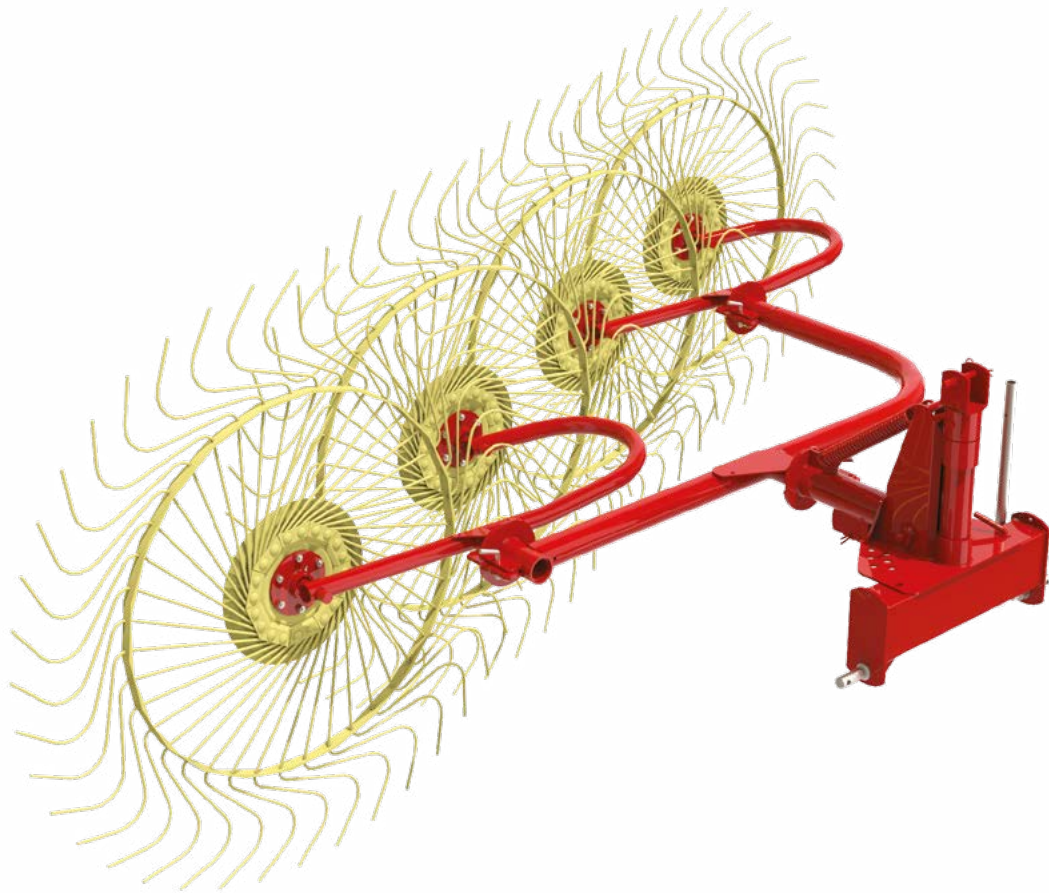

— The RP 2C and RP 3C models are available with CAT I hitch. All the others with CAT II hitch.

Les modèles RP 2C et RP 3C sont disponibles avec attelage CAT I. Tous les autres avec attelage CAT II.

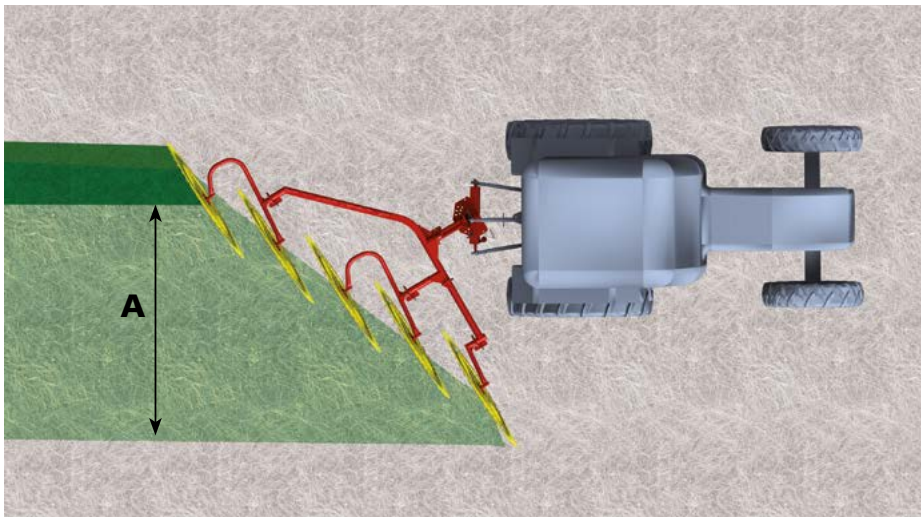

— A = working width from 130 to 440 cm.
A = largeur de travail de 130 à 440 cm.

RT

Inline rake

Râteau soleil en ligne



Quick and easy adjustment of all rake wheels.
Réglage rapide et facile de tous les soleils.

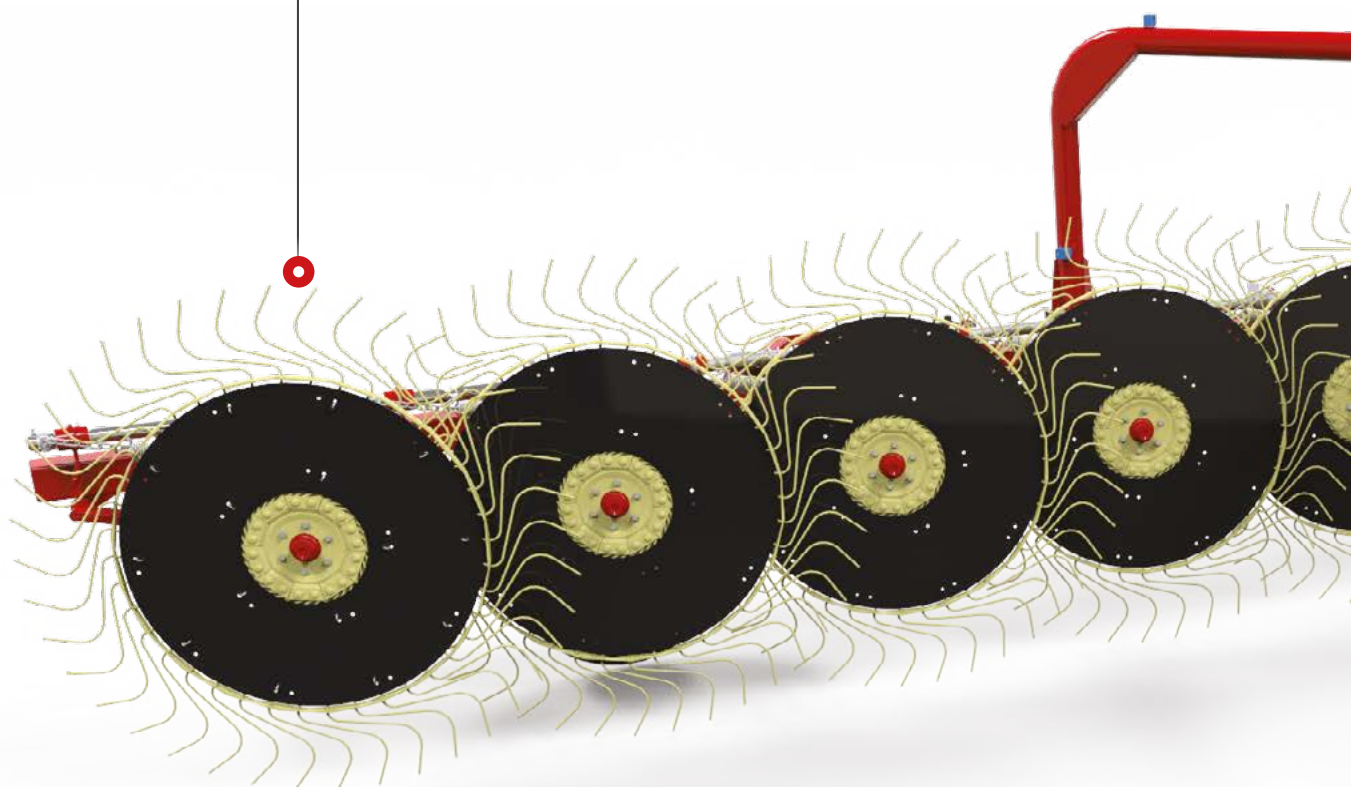



Hydraulic lifting of the rake wheels.
Levage hydraulique des soleils.



Hydraulic working width adjustment.
Réglage hydraulique de la largeur de travail.

RT

Inline rake

Râteau soleil en ligne



The RT wheel rake is designed to work on flat ground. It has the advantage of being able to form either a single windrow (with one pass), or two windrows next to each other (one forward and one in return).

Le râteau soleil RT est conçu pour travailler sur terrain plat. Il a l'avantage de pouvoir former un seul andain (avec un passage), ou deux andains proches l'un de l'autre (aller et retour).

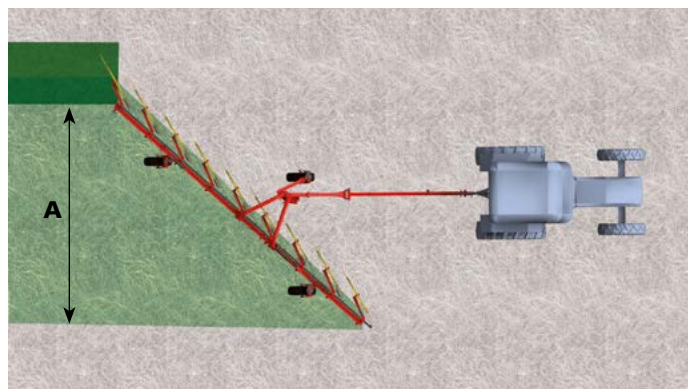

A = working width from 430 to 760 cm.
A = Largeur de travail de 430 à 760 cm.

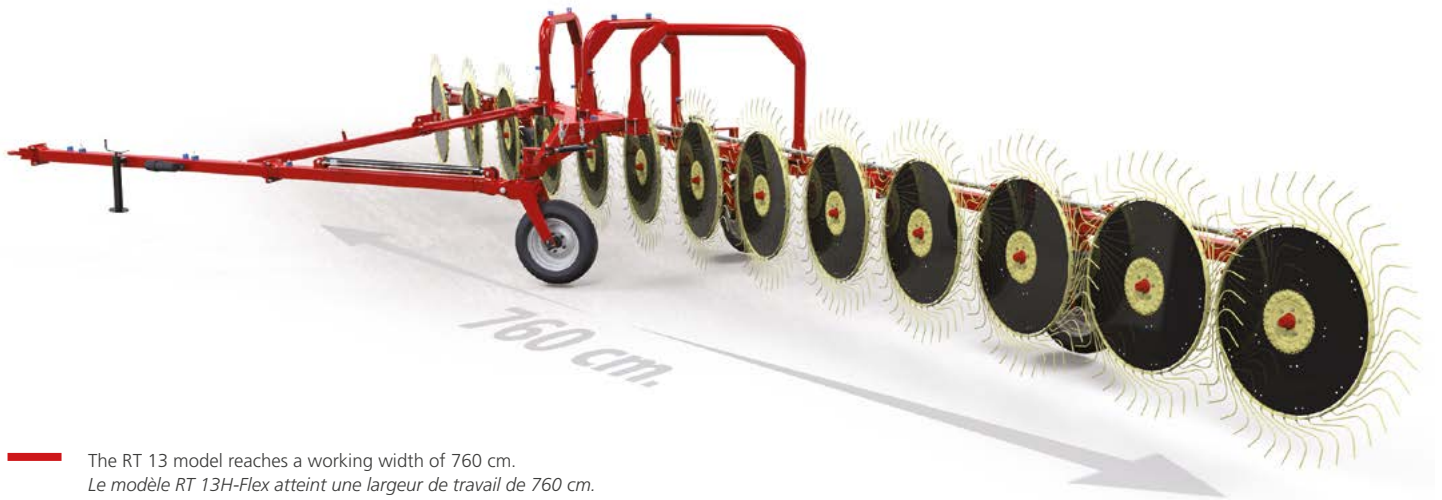

The RT 13 model reaches a working width of 760 cm.
Le modèle RT 13H-Flex atteint une largeur de travail de 760 cm.



Independent spring to adjust the pressure of the rake wheel on the ground.
Ressort indépendant pour régler la pression des soleils au sol.

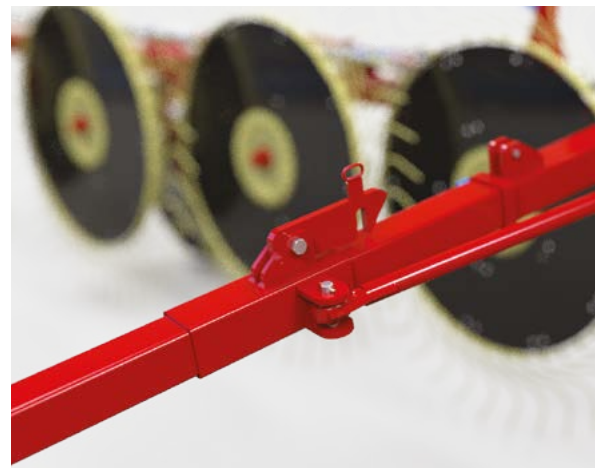



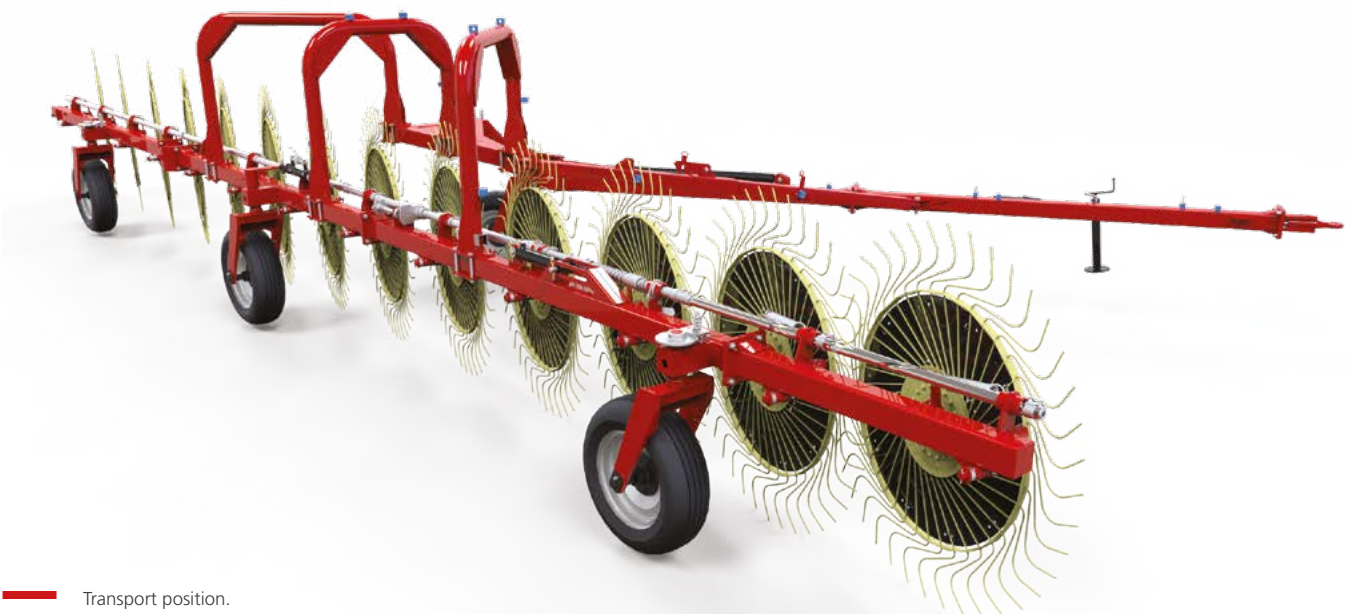





















Mechanical locking of the rake.
Verrouillage mécanique du râseau.



Transport position.
Position de transport.

Technical Data / Données techniques

		RP			
		RP 2C	RP 3C	RP 4	RP 5BS
General / Général	 Working width Largeur de travail	130 cm. 4.3 ft.	195 cm. 6.4 ft.	240-280 cm. 7.9-9.2 ft.	300-350 cm. 9.8-11.5 ft.
	 Working width adjustment Réglage de la largeur de travail	Mechanical / Mécanique			
	 Minimum power Min. puissance	25 HP	25 HP	40 HP	40 HP
	 Machine weight approx Poids de la machine env.	90 kg 198 Lbs.	120 kg 265 Lbs.	178 kg 392 Lbs.	210 kg 463 Lbs.
Wheels / Soleils	 Rake wheels number Nombre soleils	2	3	4	5
	 Rake bearings wheels Roulements des soleils	Tapered roller / Rouleau conique			
	 Rake wheel bearing Diamètre des soleils	145 cm. / 4.7 ft.			
	 Teeth diameter Diamètre des dents	6,9 mm. / 0.27"			
	 Teeth number each wheel Nombre de dents par soleil	40			
	 Wind guard Disques ABS	□	□	□	□
	 Lifting of rake wheels Levage soleils	Third hitch point / 3 points			
	 Rake wheels ground adaptation Adaptation soleils au sol	Double rake wheel on arm <i>Bras à double soleil</i>	Arm with 3 rake wheels <i>Bras à 3 soleils</i>	Double rake wheel on arm / <i>Bras à double soleil</i>	
	 Rake wheels ground pressure Pression soleils au sol	-	-	Double spring on the frame / <i>Double ressort sur le châssis</i>	
	Frame / Châssis	 Articulated rake arm Bras articulé	-	-	-
 Rake wheel frame kit extension for transport Kit d'extension de châssis porte-soleil pour transport		-	-	-	□
Transport / Transport	 Cushioned pivoting wheels Roues pivotantes amorties	-	-	-	-
	 Transport wheels Roues de transport	-	-	-	-
	 Transport width Largeur de transport	230 cm. 7.5 ft.	280 cm. 9.2 ft.	235 cm. 7.7 ft.	320 cm. 10.5 ft.
	 Transport length Longueur de transport	200 cm. 6.6 ft.	200 cm. 6.6 ft.	300 cm. 9.8 ft.	320 cm. / 10.5 ft. (440 cm. / 14.4 ft. with extension / avec rallonge)
	 Street lights and signals Kit feux et signalisation routière	-	-	-	-
	 Hydraulic brake Frein hydraulique	-	-	-	-
	 Spare wheel kit Kit roue de secours	-	-	-	-
	 Hydraulic connections required Connexions hydrauliques nécessaires	-	-	-	-
	 Hitch Attelage	3 points hitched / 3 points			

● Standard / Standard □ Optional / En option - Not available / No disponible

RT		
RT 7	RT 9	RT 13H-Flex
430 cm. 14.1 ft.	560 cm. 18.4 ft.	760 cm. 24.9 ft.
Mechanical (Hydraulic opt.) / <i>Mécanique (opt. Hydraulique)</i>		Hydraulic / <i>Hydraulique</i>
60 HP	60 HP	60 HP
645 kg 1422 Lbs.	735 kg 1620 Lbs.	1250 kg 2756 Lbs.
7	9	13
Tapered roller / <i>Rouleau conique</i>		
145 cm. / 4.7 ft.		
6,9 mm. / 0.27"		
40		
□	□	□
Hydraulic / <i>Hydrauliquement</i>		
Independent arms / <i>Bras indépendantes</i>		
Independent spring on each rake wheel / <i>Ressort indépendant pour chaque soleil</i>		
-	-	Articulated frame <i>Châssis articulé</i>
-	-	-
-	-	-
1Fix+2Piv - 195/65 - R15		
250 cm. 8.2 ft.	250 cm. 8.2 ft.	250 cm. 8.2 ft.
760 cm. 24.9 ft.	950 cm. 31.2 ft.	1190 cm. 39 ft.
□	□	□
-	-	-
□	□	□
1 SE (1 DE opt)	1 SE (1 DE opt)	1 SE (1 DE opt)
Trailed / <i>Traîné</i>		



CADDY

“V” frame with central joint rake

Râteau en “V” avec joint central



Ground adaptation of rake wheels with **rocker system**.

Adaptation au sol des soleils avec système à bascule.

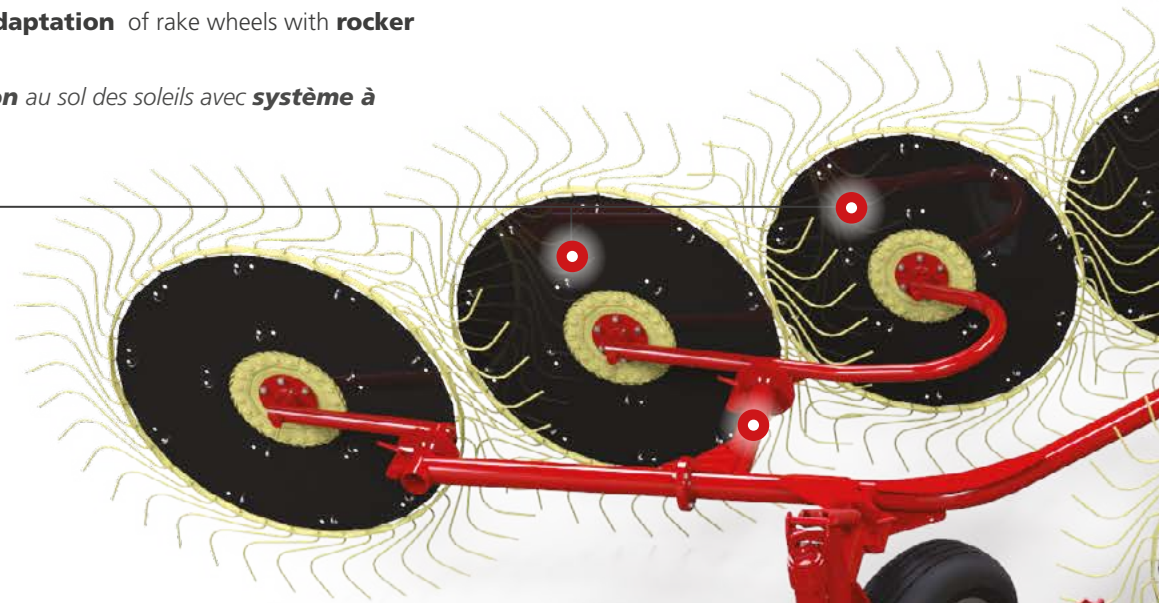

Mechanical working width adjustment.

Réglage manuel de la largeur de travail.



Central rake wheel kit (optional).

Kit soleil central (en option).



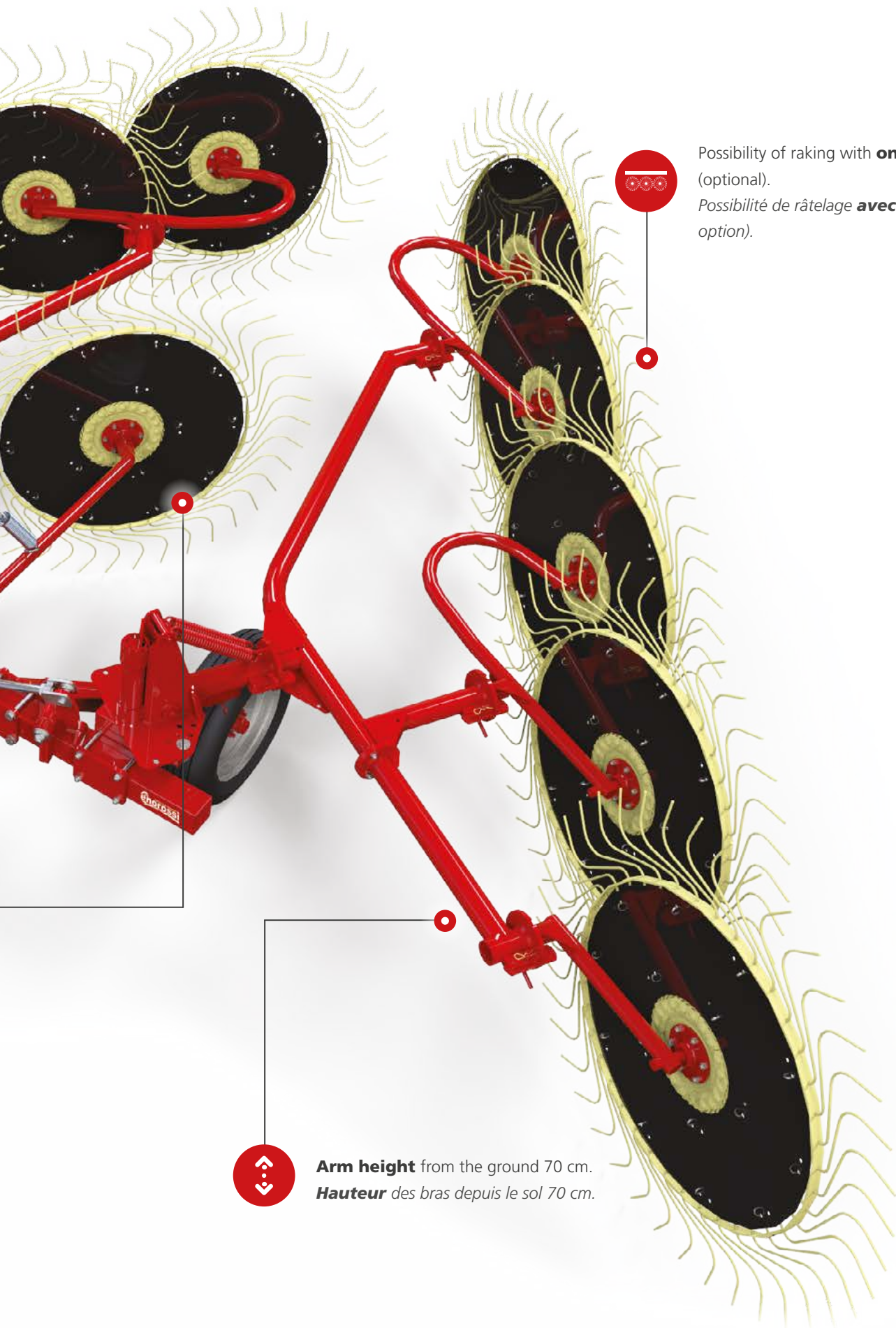

Possibility of raking with **only one arm** (optional).
*Possibilité de râtelage **avec un seul bras** (en option).*



Arm height from the ground 70 cm.
***Hauteur** des bras depuis le sol 70 cm.*

CADDY

“V” frame with central joint rake

Râteau en “V” avec joint central



The CADDY wheel rake is ideal for small extensions. It forms a central windrow whose width is mechanically adjustable. The wide wheelbase makes the machine stable during work and transport.

Le râteau soleil CADDY est idéal pour les petites extensions. Il forme un andain central dont la largeur est réglable mécaniquement. L'empattement large rend la machine stable pendant le travail et le transport.

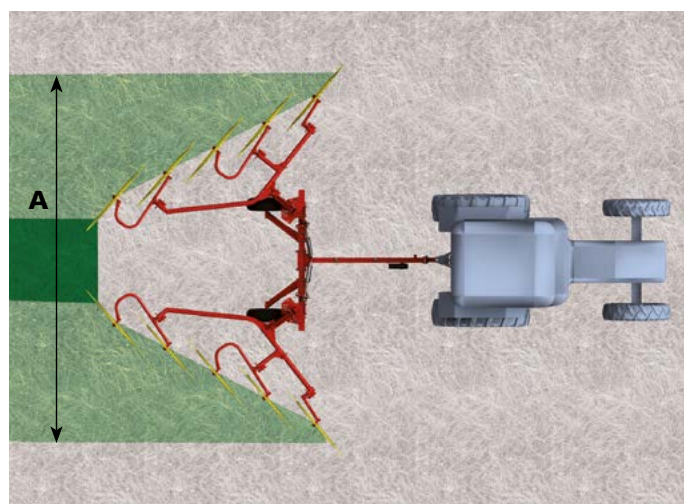

A = Working width from 480 to 740 cm.
A = Largeur de travail de 480 à 740 cm.



Hydraulic lifting of the arms and adjustment of the working width

Levage hydraulique des bras et réglage largeur de travail

The hydraulic lifting system allows you to quickly switch from the work to the transport position in a simple and fast way. The working width is mechanically adjustable.

Le système de levage hydraulique vous permet de passer rapidement de la position de travail à la position de transport de manière simple et rapide. La largeur de travail est réglable mécaniquement.



Shiftable wheels and wide wheelbase

Roues mobiles et empattement large

The shiftable wheels allow the adjustment of the wheelbase by adapting the machine to the various working conditions, increasing adherence to the ground, even on uneven ground.

The wide wheelbase makes the machine stable and safe for road transport.

Les roues mobiles permettent le réglage de l'empattement en adaptant la machine aux différentes conditions de travail, augmentant l'adhérence au sol, même sur terrain accidenté.

L'empattement large rend la machine stable et sûre pour le transport routier.

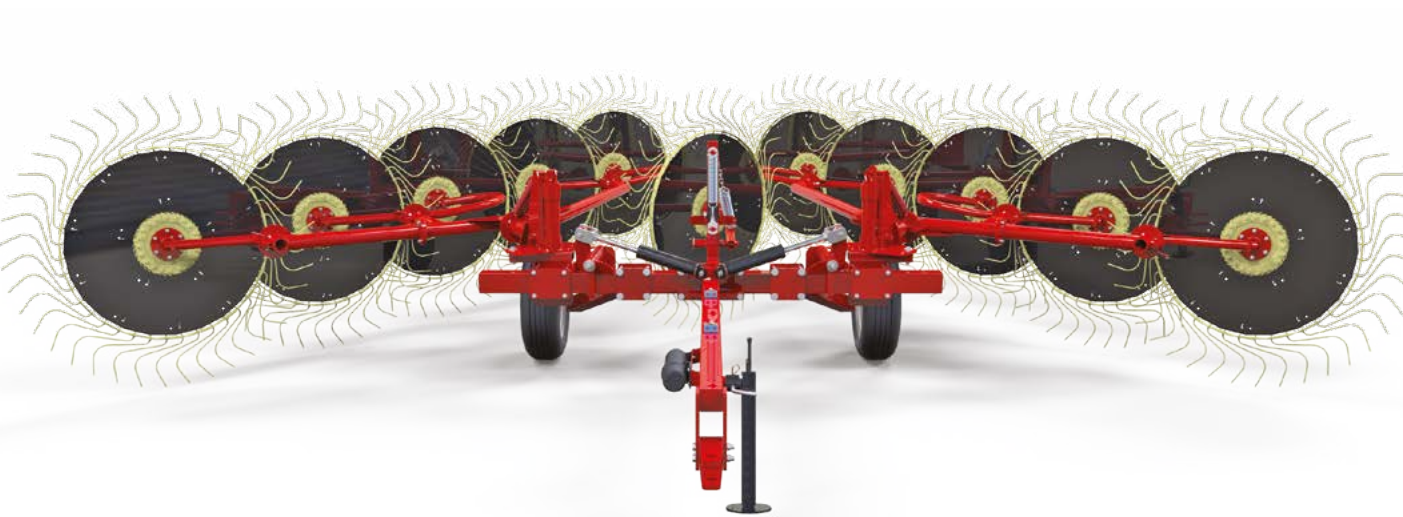

BATRAKE

“V” frame with central joint rake

Râteau en “V” avec joint central



Central rake wheel kit (optional).
Kit soleil central (en option).

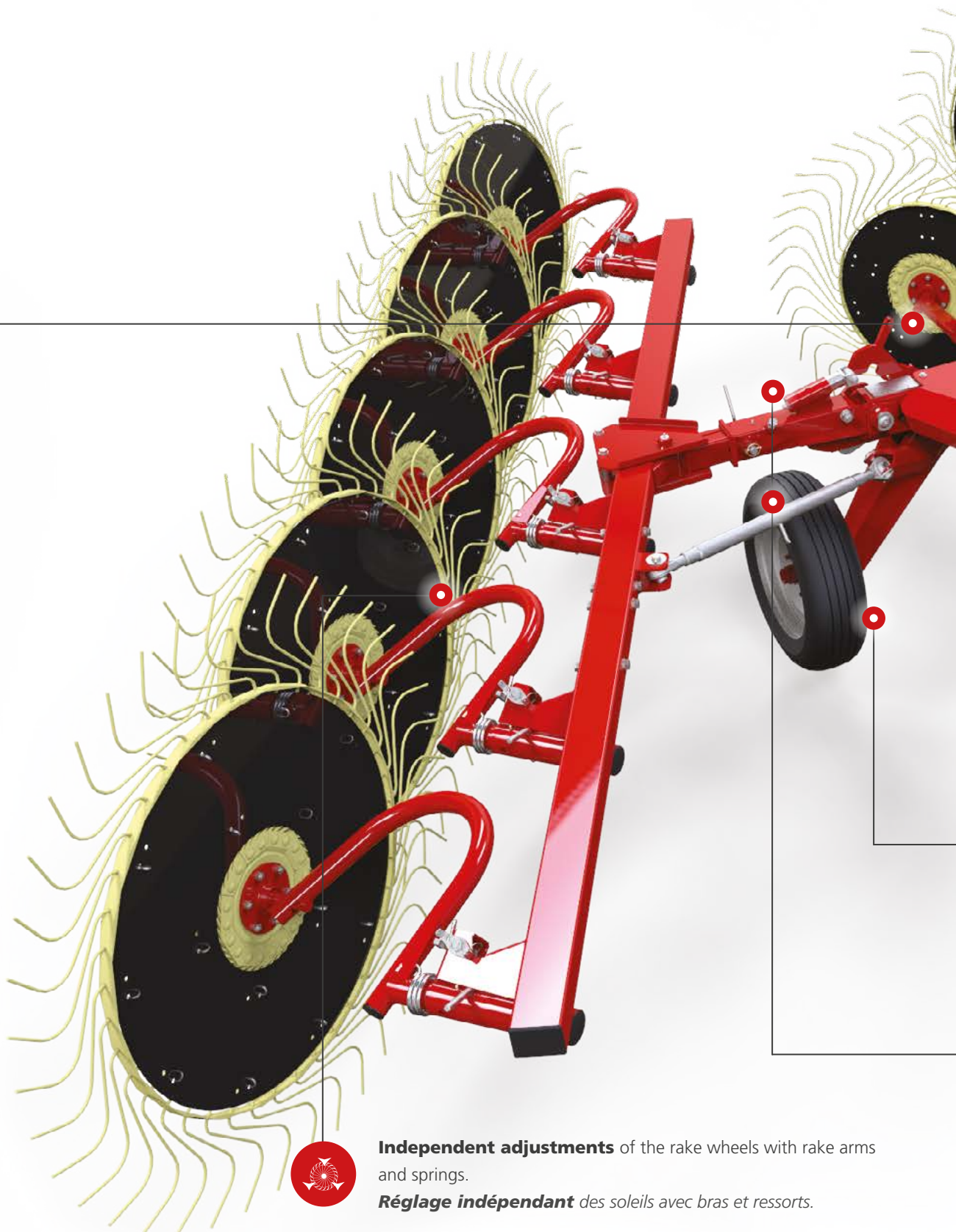

Independent adjustments of the rake wheels with rake arms and springs.

Réglage indépendant des soleils avec bras et ressorts.



Possibility of raking with **only one arm**.
*Possibilité de râtelage **avec un seul bras** (en option).*



Arm height from the ground 85 cm.
***Hauteur des bras** depuis le sol 85 cm.*



Tandem axle (optional).
***Essieu tandem** (en option).*



Mechanical working width adjustment
(Hydraulic optional).
***Réglage mécanique** de la largeur de travail
(réglage hydraulique en option).*

BATRAKE

“V” frame with central joint rake

Râteau en “V” avec joint central



The BATRAKE wheel rake is ideal for medium to small areas with an average amount of product to collect.

Le râteau soleil BATRAKE est idéal pour les petites et moyennes surfaces avec une quantité moyenne de produit à collecter.

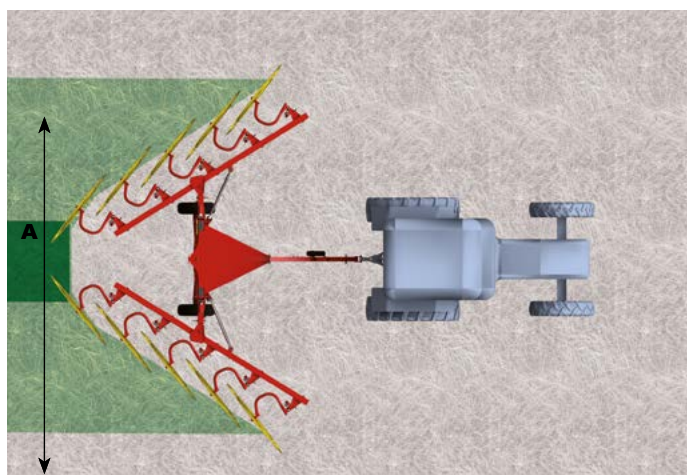

— A = Working width from 500 to 740 cm.
A = Largeur de travail de 500 à 740 cm.

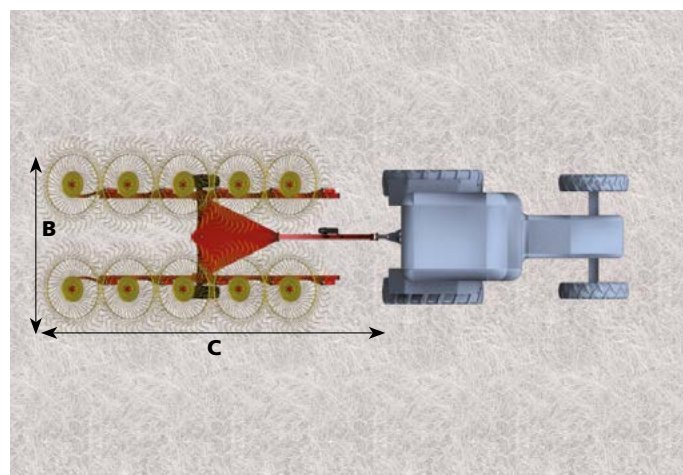

— B = Transport length 275 cm.
C = Transport length from 250 to 665 cm.
B = Largeur de transport 275 cm.
C = Longueur de transport de 250 à 665 cm.



Telescopic frame
Châssis télescopique

The windrow width adjustment is easily obtained through the mechanically operated telescopic frame.

Le réglage de la largeur d'andain s'effectue facilement grâce au châssis télescopique à commande mécanique.



Independent rake arms and wheels with spring pressure adjustment to the ground
Bras de soleils indépendant avec réglage de la pression du ressort au sol

Each rake arm is equipped with an adjustable torsion spring that allows you to vary the pressure on the ground for excellent collection and windrow formation maintaining a uniformity of work in the field.

Chaque bras porte-soleil est équipé d'un ressort de torsion réglable qui vous permet de faire varier la pression au sol pour une excellente récolte et formation d'andains, tout en maintenant l'uniformité du travail dans le champ.



MAXIMUS

“V” frame with central joint rake

Râteau en “V” avec joint central

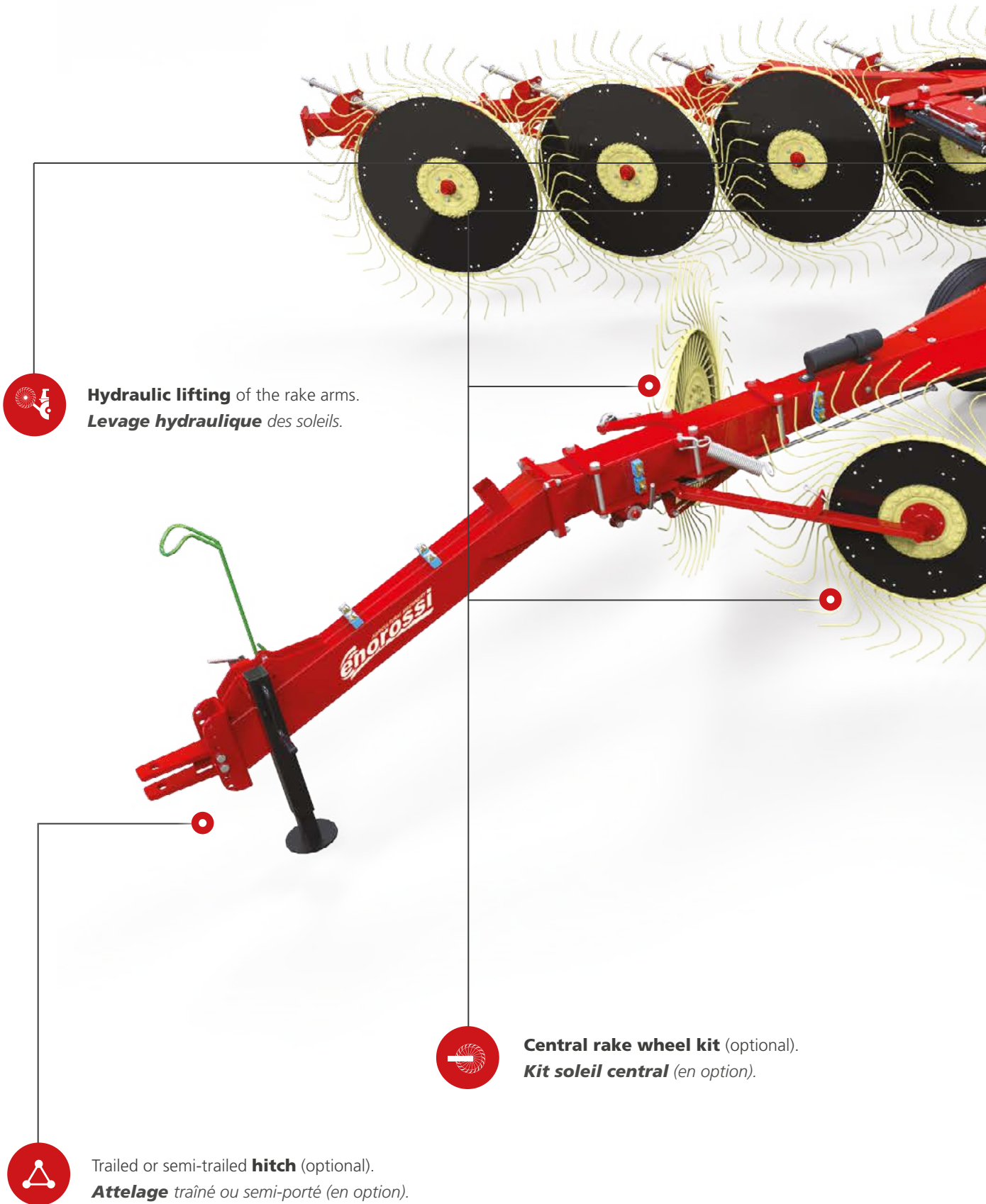

Hydraulic lifting of the rake arms.
Levage hydraulique des soleils.



Central rake wheel kit (optional).
Kit soleil central (en option).



Trailed or semi-trailed **hitch** (optional).
Attelage traîné ou semi-porté (en option).

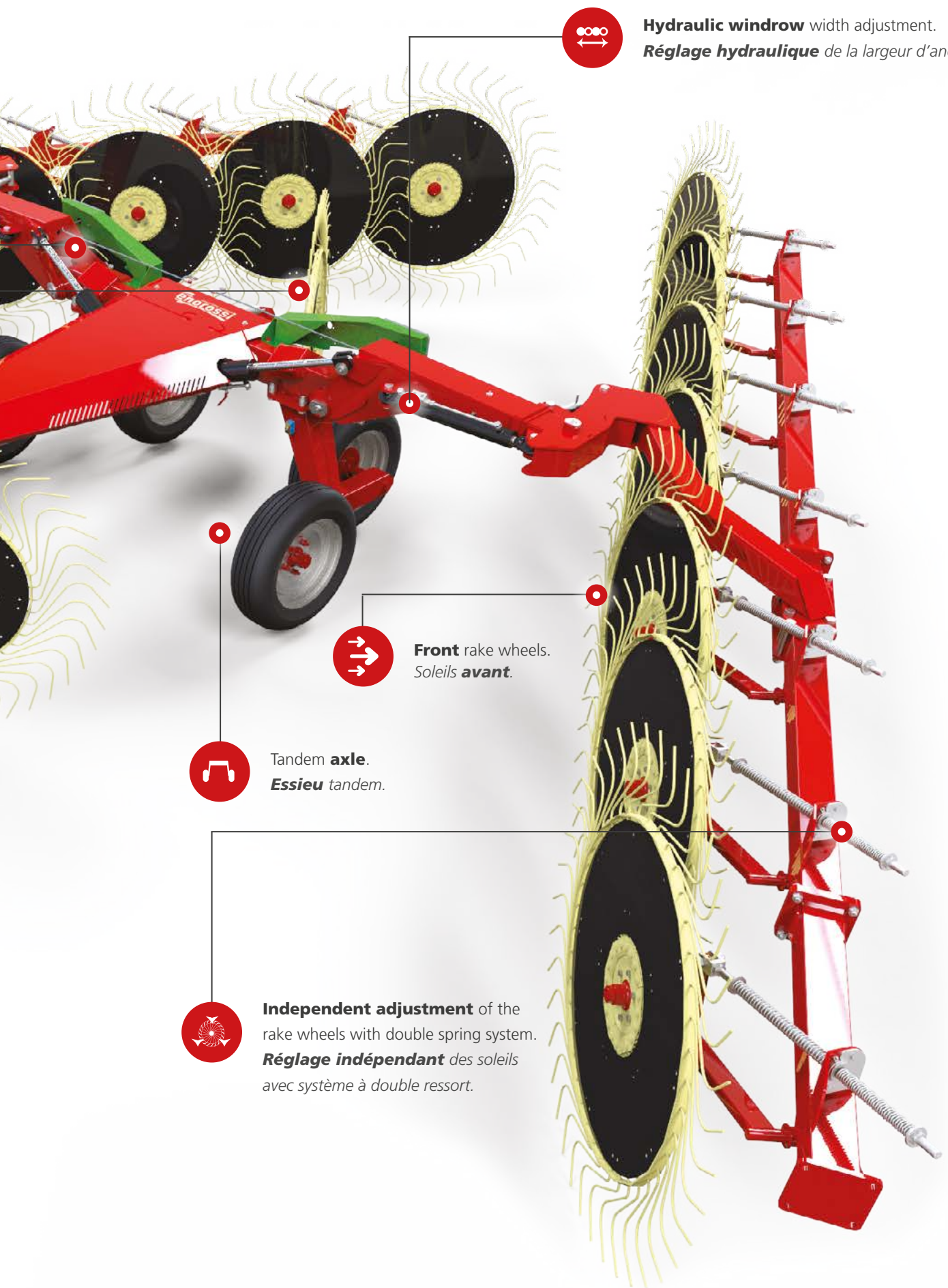

Hydraulic windrow width adjustment.
Réglage hydraulique de la largeur d'andain.



Front rake wheels.
Soleils avant.



Tandem axle.
Essieu tandem.



Independent adjustment of the rake wheels with double spring system.
Réglage indépendant des soleils avec système à double ressort.

MAXIMUS

“V” frame with central joint rake

Rastrillo en V con articulación central



The MAXIMUS wheel rake is a professional machine ideal for medium extensions. The advantage of the front rake wheels compared to the frame make it suitable for work in heavy crop conditions.

Le râtelier soleil MAXIMUS est une machine professionnelle idéale pour les moyennes extensions. L'avantage des soleils avant sur le châssis le rend adapté au travail dans des conditions de récolte intensive.

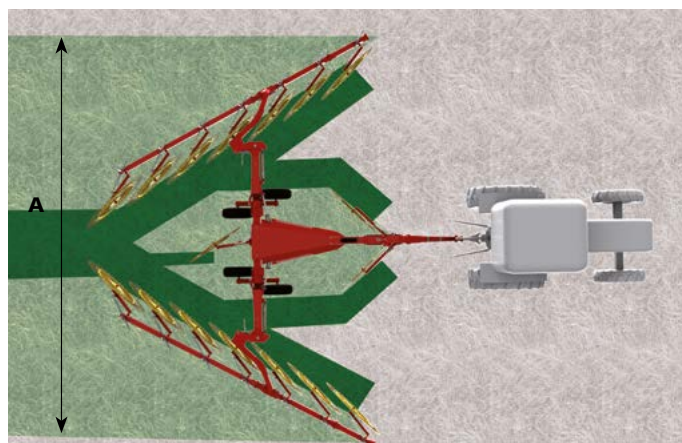

A = Working width from 660 to 920 cm.
A = Largeur de travail de 660 à 920 cm.



Front rake wheels
Soleils avant

The rake wheels, in front of the frame, guarantee a greater collection resistance suitable for any product quality.

Les soleils, devant le châssis, garantissent une plus grande résistance à la récolte adaptée à toute qualité de produit.

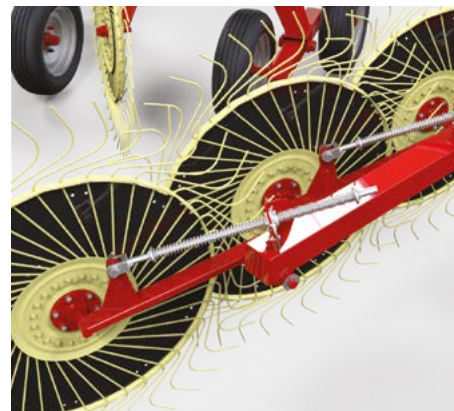
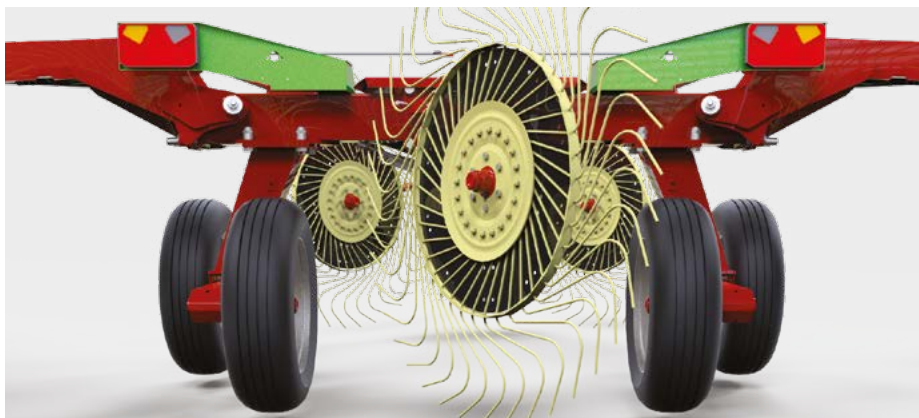

Tandem axle and central rake wheel kit
Essieu tandem et kit soleils centraux

The tandem wheels allow a perfect adaptation to the ground. The central rake wheels kit (optional), consisting of 3 rake wheels, guarantees perfect product turning over the entire windrow.

Les roues tandem permettent une parfaite adaptation au sol. Le kit soleils centraux (en option), composé de 3 soleils, garantit un parfait retournement du produit sur l'ensemble de l'andain.



































— Double spring pressure adjustment and ground adaptation of the rake wheels.

Réglage de la pression à double ressort et adaptation des soleils au sol.



— Transport position.
Position de transport.

Technical Data / Données techniques

		CADDY		
		CADDY 8	CADDY 10	CADDY 12
General / Général	 Working width Minimum / Maximum Largeur de travail min. /max.	480-540 cm. 15.7-17.7 ft.	580-640 cm. 19-21 ft.	680-740 cm. 22.3-24.3 ft.
	 Working width adjustment Réglage de la largeur de travail	Mechanical / Mécanique		
	 Windrow width adjustment Min. /Max. Largeur d'andain min. /max.	50-200 cm. / 1.6-6.6 ft.		
	 Windrow width adjustment Réglage de la largeur d'andain	Mechanical / Mécanique		
	 Minimum power Min. puissance	40 HP	50 HP	50 HP
	 Machine weight approx. Poids de la machine env.	600 Kg 1322 Lbs.	660 Kg 1455 Lbs.	730 Kg 1609 Lbs.
Wheels / Soleils	 Rake wheels number Nombre soleils	8	10	12
	 Rake wheels bearing Roulements des soleils	Tapered roller / Rouleau conique		
	 Rake wheel diameter Diamètre des soleils	145 cm. / 4.7 ft.		
	 Teeth diameter Diamètre des dents	6,9 mm. / 0.27"		
	 Teeth number each wheel Nombre de dents par soleil	40 (18 each Rubberflex / 18 chaque Rubberflex)		
	 Central rake wheel Soleil central	opt. n.1, 145 cm. / 4.7 ft. Hydraulic / Hydraulique		
	 Wind guards Disque ABS	□	□	□
	 Rubberflex rake wheels Roues Rubberflex	-	-	-
	 Rake wheels lifting Levage soleils	Hydraulic / Hydraulique		
	 Rake wheels ground adaptation Adaptation soleils au sol	Double wheel on arm / Bras à double soleil		
	 Rake wheels ground pressure Pression soleils au sol	Double spring on frame / Double ressort sur le châssis		
Frame / Châssis	 Articulated rake arm Bras articulé	-	-	-
	 Height of rake wheel frame from the ground Hauteur du châssis des soleils depuis le sol	70 cm. / 2.3 ft.		
	 Single arm raking Ratissage à un bras	□	□	□
Transport / Transport	 Pivoting wheels on arms Roues pivotantes sur les bras	-	-	-
	 Cushioned pivoting wheels Roues pivotantes amorties	-	-	-
	 Nr. Of transport wheels Nr. des roues de transport	2	2	2
	 Transport wheels Roues de transport	n.2, 195/65 R15 shiftable / mobiles		
	 Axles Essieu	Single / Individuel		
	 Transport width Largeur de transport	250 cm. / 8.2 ft.		
	 Transport length Longueur de transport	480 cm. 15.7 ft.	540 cm. 17.7 ft.	570 cm. 18.7 ft.
	 Street lights and signals Kit feux et signalisation routière	□	□	□
	 Hydraulic brake Frein hydraulique	-	-	-
	 Spare wheel kit Kit roue de secours	-	-	-
Hitch / Attelage	 Hydraulic connections required Connexions hydrauliques nécessaires	1DE	1DE	1DE
	 Hitch Attelage	Trailed / Trainé		
	 Self-steering system Système auto directionnel	-	-	-
	 Oscillating crossbar for lifter Traverse oscillante pour élévateur	□	□	□

• Standard / Standard □ Optional / En option - Not available / No disponible

BATRAKE			MAXIMUS		
BAT 8	BAT 10	BAT 12	MAX 12	MAX 14	MAX 16
500-560 cm. 16.4-18.4 ft.	560-660 cm. 18.4-21.7 ft.	600-740 cm. 19.7-24.3 ft.	660-740 cm. 21.6-24.3 ft.	750-830 cm. 24.6-27.2 ft.	840-920 cm. 27.6-30.2 ft.
Mechanical (Hydraulic opt.) / Mécanique (opt. Hydraulique)			Hydraulic / Hydraulique		
50-200 cm. / 1.6-6.6 ft.			50-200 cm. / 1.6-6.6 ft.		
Mechanical (Hydraulic opt.) / Mécanique (opt. Hydraulique)			Hydraulic / Hydraulique		
40 HP	50 HP	50 HP	60 HP	60 HP	60 HP
680 Kg 1500 Lbs.	780 Kg 1620 Lbs.	890 Kg 1960 Lbs.	1390 Kg 3064 Lbs.	1500 Kg 3307 Lbs.	1700 Kg 3748 Lbs.
8	10	12	12	14	16
Tapered roller / Rouleau conique			Tapered roller / Rouleau conique		
150 cm. / 4.9 ft.			150 cm. / 4.9 ft.		
7,5 mm. / 0.295"			7,5 mm. / 0.295"		
40 (18 each Rubberflex / 18 chaque Rubberflex)			40 (18 each Rubberflex / 18 chaque Rubberflex)		
opt. n.1-3, 128 cm. / 4.1 ft. Hydraulic / Hydraulique			opt. n.3, 128 cm. / 4.1 ft. Hydraulic / Hydraulique		
□	□	□	□	□	□
-	-	-	□	□	□
Hydraulic / Hydraulique			Hydraulic / Hydraulique		
Independent arms / Bras indépendantes			Independent arms / Bras indépendantes		
Spring on frame and on each rake arm / Ressort sur le châssis et sur chaque bras			Double spring on each rake arm / Double ressort sur chaque bras		
-	-	-	-	-	-
85 cm. / 2.8 ft.			Rear frame / Châssis arrière		
•	•	•	•	•	•
-	-	-	-	2 opt 18,5/8,5 R8	2 x 18,5/8,5 R8
-	-	-	-	-	-
2	2	2	4	4	4
n.2, 195/65 R15			n.4, 195/65 R15		
Single (tandem optional) / Individuel (tandem en option) (n.2, 195/65 R15 + n.2 18,5/8,5 R8)			Tandem / Tandem		
250 cm. / 8.2 ft.			255 cm. / 8.4 ft.		
570 cm. 18.7 ft.	570 cm. 18.7 ft.	650 cm. 21.3 ft.	740 cm. 24.3 ft.	740 cm. 24.3 ft.	830 cm. 27.2 ft.
□	□	□	□	□	□
-	-	-	-	-	-
-	-	-	•	•	•
1 SE +1DE opt.	1 SE +1DE opt.	1 SE +1DE opt.	2DE	2DE	2DE
Trailed / Traîné			Trailed / Traîné		
-	-	-	-	-	-
□	□	□	□	□	□

EASY RAKE

“V” frame with rear joint rake

Râteau en “V” avec joint arrière



Self-steering system. Steering angle 90°. Only in ST models.

Système auto directionnel. Angle de braquage 90°. Seulement sur les modèles ST.



Rake wheels rubberflex (optional).
Soleils Rubberflex (en option).



Central wheels kit (optional).
Kit soleil central (en option).



Semi-mounted self-steering (ER ST) or trailed (ER) hitch.

Attelage semi-porté auto directionnel (ER ST) ou traîné (ER).

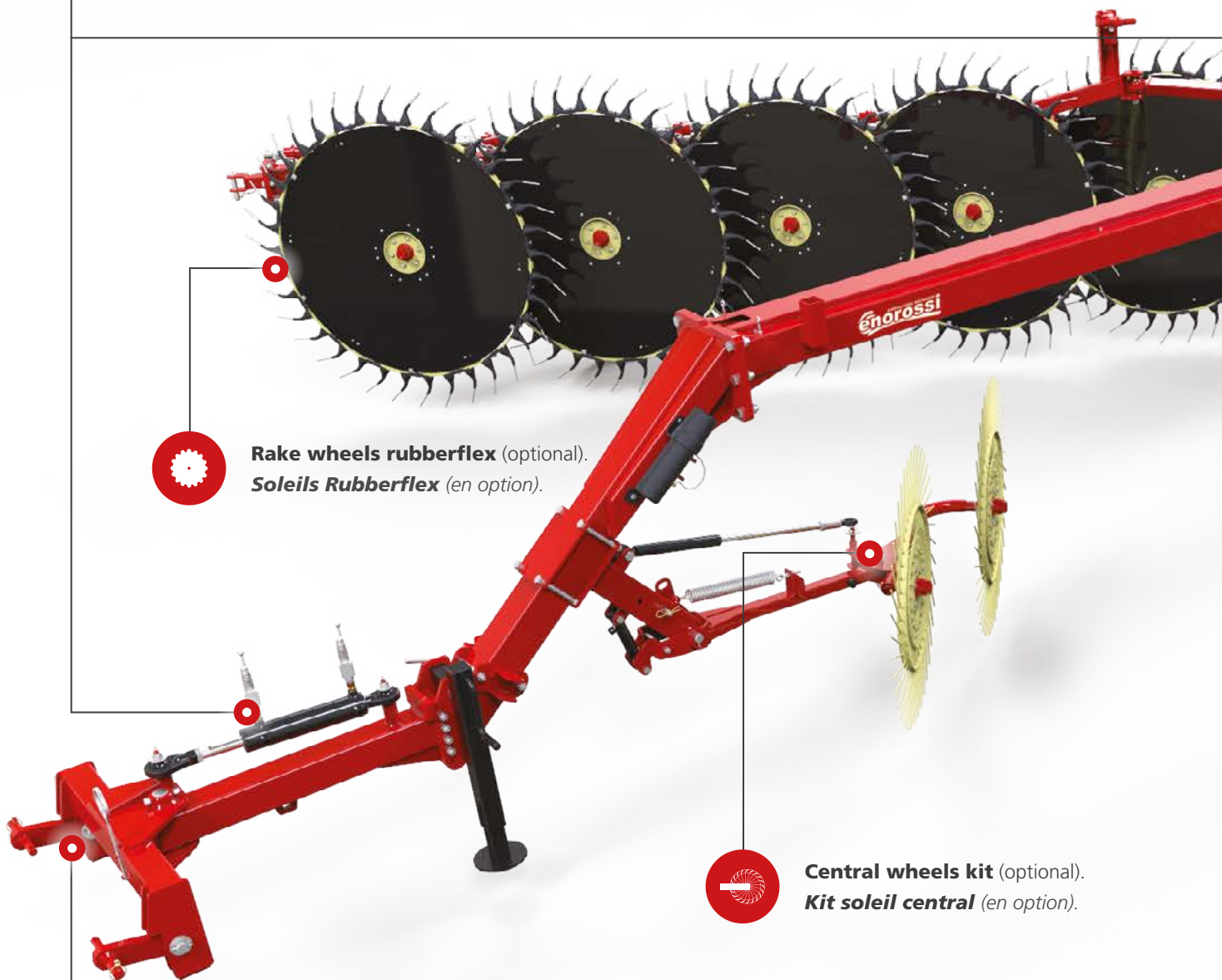

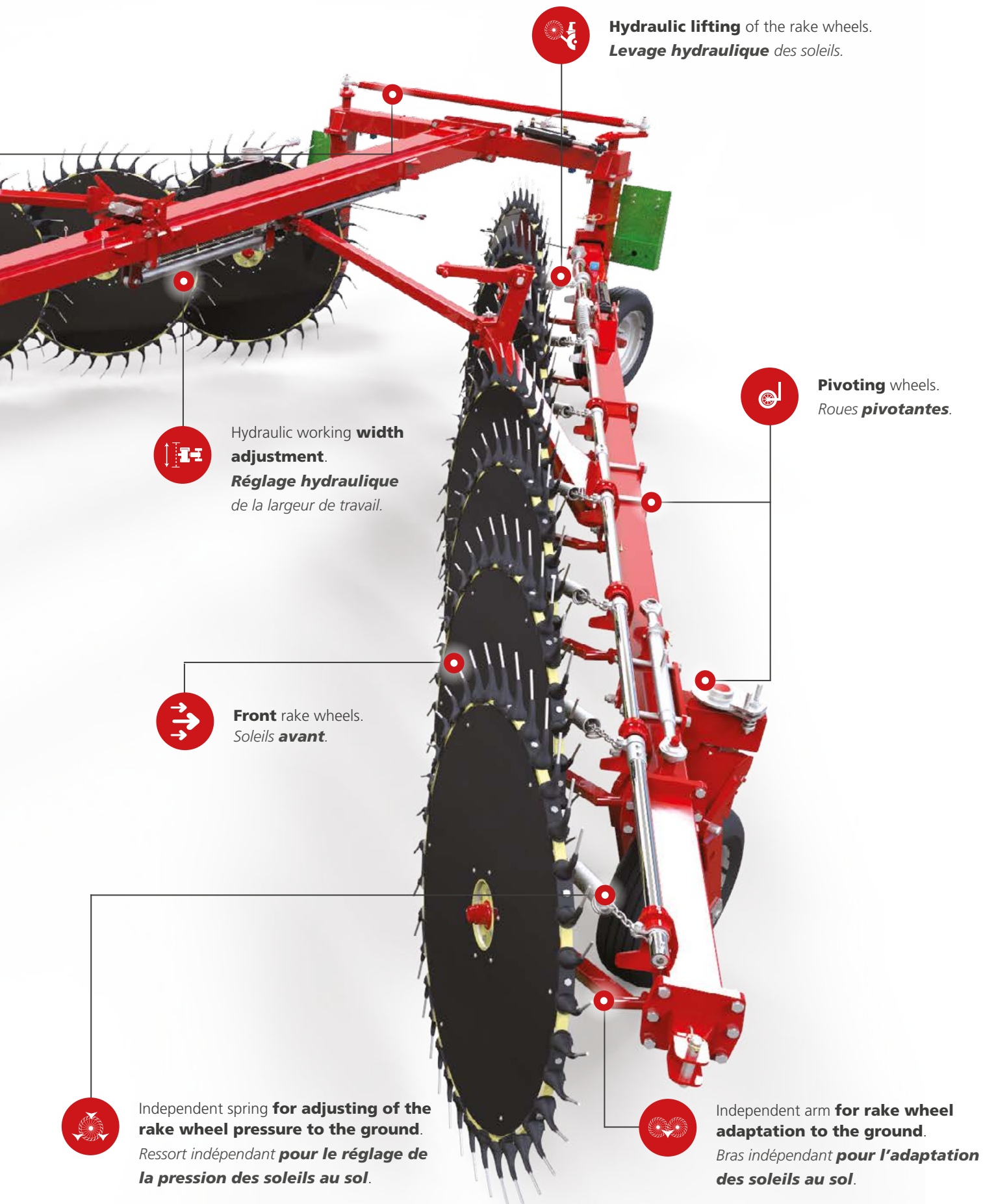

Hydraulic lifting of the rake wheels.
Levage hydraulique des soleils.



Hydraulic working width adjustment.
Réglage hydraulique de la largeur de travail.



Pivoting wheels.
Roues pivotantes.



Front rake wheels.
Soleils avant.



Independent spring for adjusting of the rake wheel pressure to the ground.
Ressort indépendant pour le réglage de la pression des soleils au sol.



Independent arm for rake wheel adaptation to the ground.
Bras indépendant pour l'adaptation des soleils au sol.

EASY RAKE

“V” frame with rear joint rake

Râteau en “V” avec joint arrière



The Easy Rake is a professional machine, designed for medium-large areas. It adapts to all types of soil and forage conditions. It is available in the trailed (ER) and semi-mounted self-steering (ER ST) version.

The windrow width adjustment is mechanical with 3 positions.

Le râteau soleil Easy Rake est une machine professionnelle, conçue pour les moyennes et grandes surfaces. Il s'adapte à tous types de terrains et conditions de fourrage. Il est disponible dans la version traînée (ER) et semi-portée auto-directionnel (ER ST).

Le réglage de la largeur d'andain est mécanique à 3 positions.

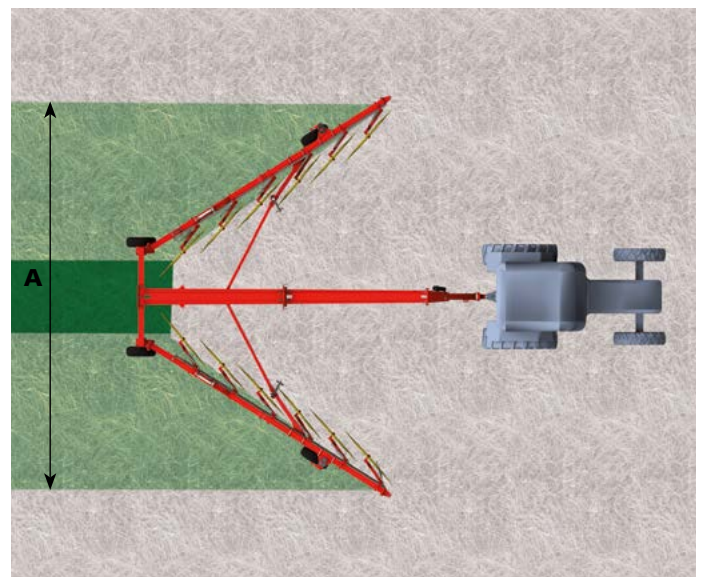

A = Easy Rake working width from 630 to 830 cm.
A = Largeur de travail Easy Rake de 630 à 830 cm.

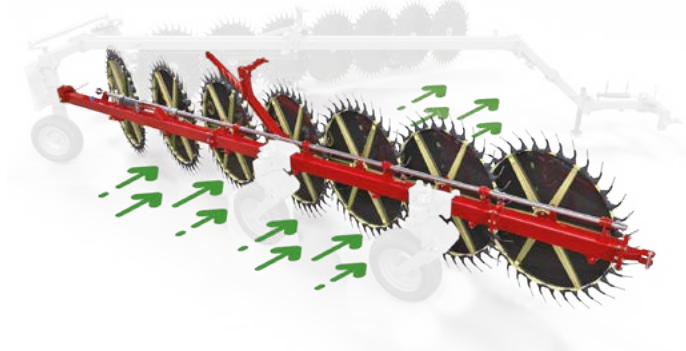

Front rake wheels
Soleils avant

The rake wheels, in front of the frame, guarantee a greater collection resistance suitable for any product quality.

Les soleils, devant le châssis, garantissent une plus grande résistance à la récolte adaptée à toute qualité de produit.



"ST" self-steering system
Système auto directionnel "ST"

The "ST" self-steering system allows a steering angle of 90°, therefore greater maneuverability in the field and easy transport on the road.

Le système auto directionnel "ST" permet un angle de braquage de 90°, donc une plus grande maniabilité sur le terrain et un transport facile dans la route.



Pivoting wheels
Roues pivotantes

Pivoting wheels with anti-pivoting brake during transport.

Roues pivotantes avec frein anti-pivotement pendant le transport.



— Transport position.
Position de transport.

EASY RAKE SUPERSTAR

“V” frame with rear joint rake

Râteau en “V” avec joint arrière

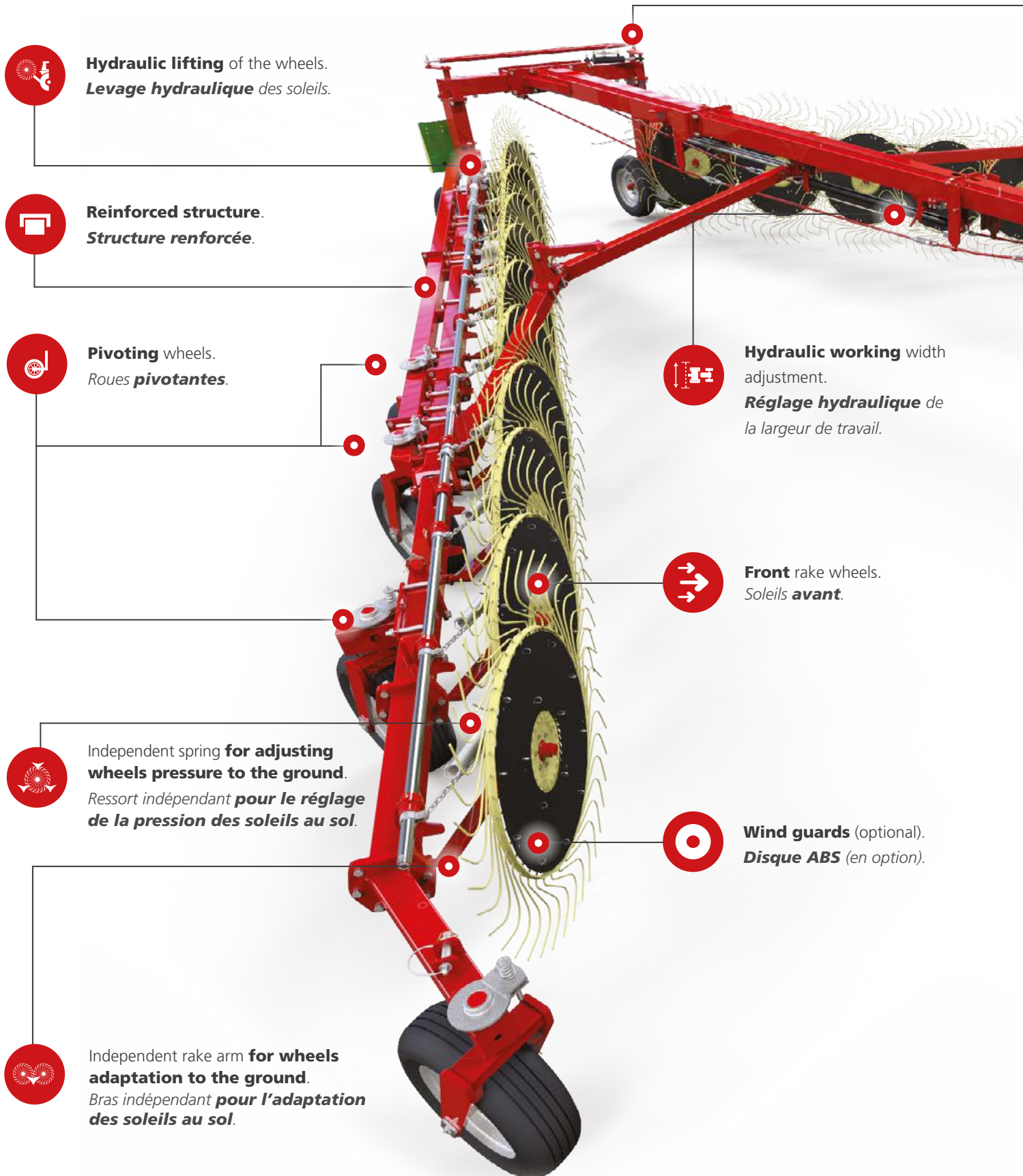

Hydraulic lifting of the wheels.
Levage hydraulique des soleils.



Reinforced structure.
Structure renforcée.



Pivoting wheels.
Roues pivotantes.



Hydraulic working width adjustment.
Réglage hydraulique de la largeur de travail.



Front rake wheels.
Soleils avant.



Independent spring **for adjusting wheels pressure to the ground.**
Ressort indépendant pour le réglage de la pression des soleils au sol.



Wind guards (optional).
Disque ABS (en option).



Independent rake arm **for wheels adaptation to the ground.**
Bras indépendant pour l'adaptation des soleils au sol.



"ST" self-steering system. Steering angle 90°.
Système auto directionnel "ST". Angle de braquage 90°.



Articulated frame for better adaptation to the ground (except ERS 16).
Châssis articulé (sauf ERS 16) pour meilleure adaptation au sol.



Central wheels kit (optional).
Kit soleil central (en option).



Semi-mounted self-steering (ERS-ST) or trailed (ER) hitch.
Attelage semi-porté auto directionnel (ERS-ST) ou traîné (ERS).

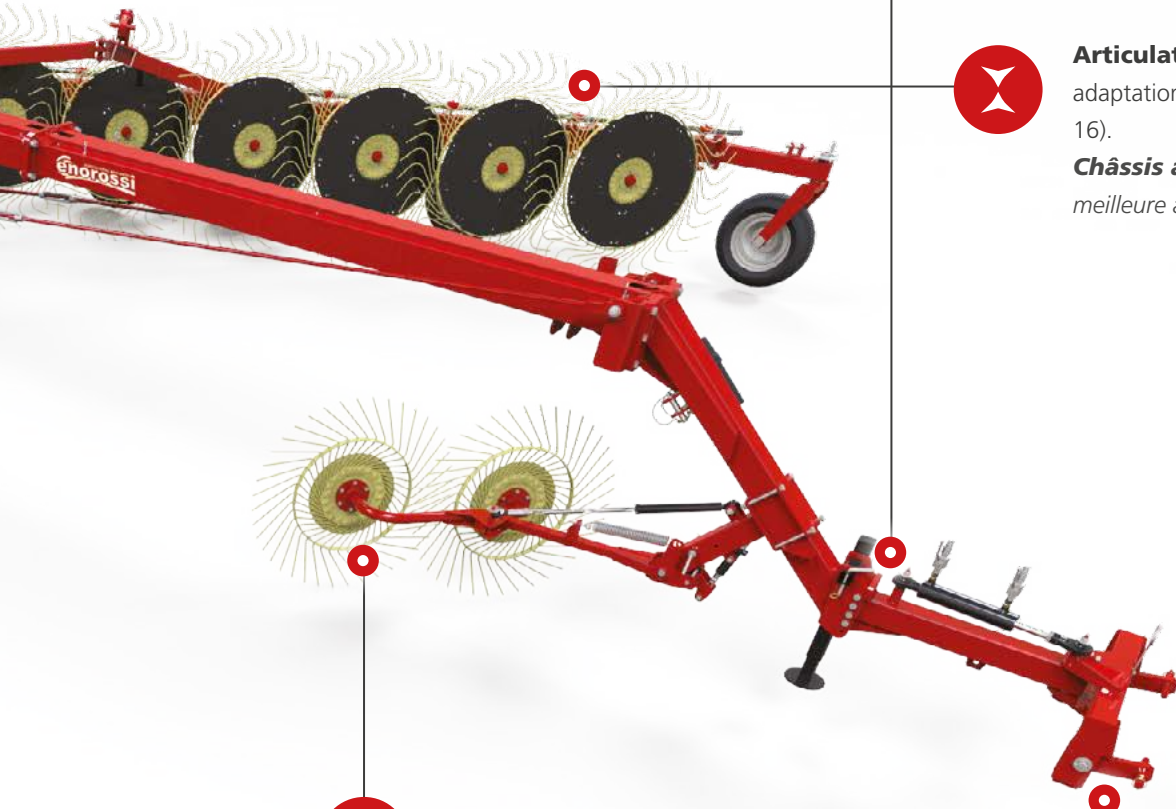

EASY RAKE SUPERSTAR

“V” frame with rear joint rake

Râteau en “V” avec joint arrière



The Easy Rake Superstar is a machine designed to work in large areas. It adapts to all types of soil and forage conditions. All models, with the exception of the ERS 16, have an articulated frame which allows the machine to better adapt to the ground.

The windrow width adjustment is mechanical with 4 positions.

Le râteau soleil Easy Rake Superstar est une machine conçue pour travailler dans de grandes surfaces. Il s'adapte à tous les types de terrain et conditions de fourrage. Tous les modèles, à l'exception de l'ERS 16, ont un châssis articulé qui permet à la machine de s'adapter mieux au sol. Le réglage de la largeur d'andain est mécanique à 4 positions.

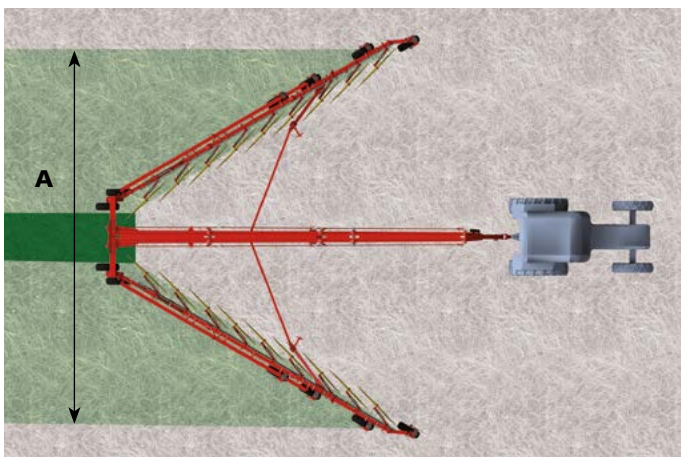

A = Easy Rake Superstar working width from 940 to 1210 cm.
A = Largeur de travail Easy Rake Superstar de 940 à 1210 cm.

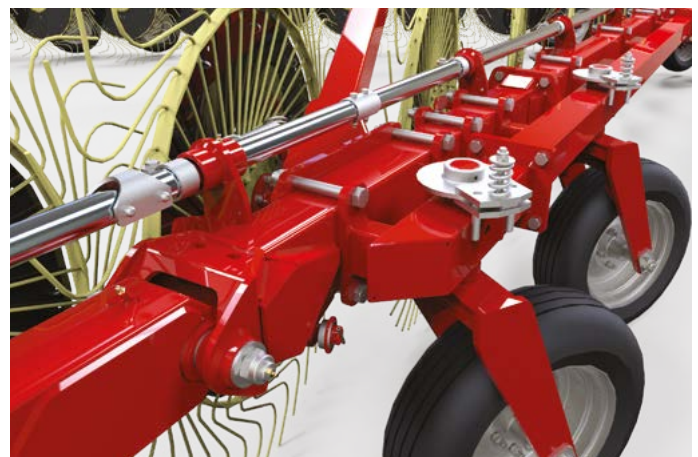

Reinforced structure on the models ERS 18, 20 and 22. The double tubular guarantees an excellent strength and flexibility to the frame.
Structure renforcée modèles ERS 18, 20 et 22. Le double tubulaire garantit au châssis une excellente résistance et flexibilité.

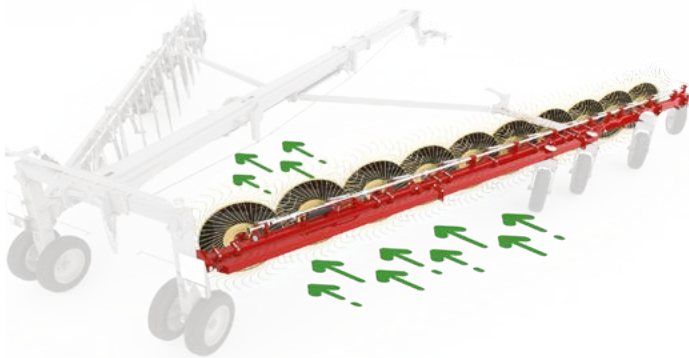

Front rake wheels
Soleils avant

The rake wheels, in front of the frame, guarantee a greater collection resistance suitable for any product quality.

Les soleils, devant le châssis, garantissent une plus grande résistance à la récolte adaptée à toute qualité de produit.



"ST" self-steering system
Système auto directionnel "ST"

The "ST" self-steering system allows a steering angle of 90°, therefore greater maneuverability in the field and easy transport on the road.

El sistema de autodirección "ST" permite un ángulo de giro de 90° garantizando una mayor maniobrabilidad en el campo y facilitando el transporte en la carretera.





































Pivoting wheels
Roues pivotantes

Pivoting wheels with anti-pivot brake during transport.

Roues pivotantes avec frein anti-pivotement pendant le transport.



Technical Data / Données techniques

		EASY RAKE					
		ER 10	ER 12	ER 14	ER 10 ST	ER 12 ST	ER 14 ST
General / Général	 Working width Minimum / Maximum Largeur de travail min. /max.	630 cm. 20.7 ft.	740 cm. 24.3 ft.	830 cm. 27.2 ft.	630 cm. 20.7 ft.	740 cm. 24.3 ft.	830 cm. 27.2 ft.
	 Working width adjustment Réglage de la largeur de travail	Hydraulic / Hydraulique					
	 Windrow width adjustment Min. /Max. Largeur d'andain min. /max.	90-120 cm. / 3-4 ft.					
	 Windrow width adjustment Réglage de la largeur d'andain	Mechanical 3-positions / Mécanique 3 positions					
	 Minimum power Min. puissance	60 HP	70 HP	80 HP	60 HP	70 HP	80 HP
	 Machine weight approx. Poids de la machine env.	1300 Kg 2866 Lbs.	1380 kg 3042 Lbs.	1680 kg 3703 Lbs.	1350 kg 2976 Lbs.	1430 kg 3150 Lbs.	1730 kg 3814 Lbs.
Wheels / Soles	 Rake wheels number Nombre soleils	10	12	14	10	12	14
	 Rake wheels bearing Roulements des soleils	Tapered roller / Rouleau conique					
	 Rake wheel diameter Diamètre des soleils	150 cm. / 4.9 ft.					
	 Teeth diameter Diamètre des dents	7,5 mm / 0,295"					
	 Teeth number each wheel Nombre de dents par soleil	40 (18 each Rubberflex / 18 chaque Rubberflex)					
	 Central rake wheel Soleil central	opt. n. 2, 95 cm / 3.1 ft. , HYD					
	 Wind guards Disque ABS	□	□	□	□	□	□
	 Rubberflex rake wheels Roues Rubberflex	□	□	□	□	□	□
	 Rake wheels lifting Levage soleils	Hydraulic / Hydraulique					
	 Rake wheels ground adaptation Adaptation soleils au sol	Independent arms / Bras indépendantes					
	 Rake wheels ground pressure Pression soleils au sol	Independent spring on each rake wheel / Ressort indépendant sur chaque soleil					
	Frame / Bastidor	 Articulated rake arm Bras articulé	-	-	-	-	-
 Height of rake wheel frame from the ground Hauteur du châssis des soleils depuis le sol		Rear frame / Châssis arrière					
 Single arm raking Ratissage à un bras		•	•	•	•	•	•
Transport / Transporte	 Pivoting wheels on frames Roues pivotantes sur les châssis	2+2 opt. 195/65 R15	2+2 opt. 195/65 R15	4 195/65 R15	2+2 opt. 195/65 R15	2+2 opt. 195/65 R15	2+2 opt. 195/65 R15
	 Cushioned pivoting wheels Roues pivotantes amorties	□	□	□	□	□	□
	 Nr. Of transport wheels Nr. des roues de transport	4	4	6	4	4	4
	 Transport wheels Roues de transport	n.4 195/65 R15	n.4+2 opt. 195/65 R15	n.6, 195/65 R15	n.4 195/65 R15	n.4+2 opt. 195/65 R15	n.4+2 opt. 195/65 R15
	 Axles Essieu	Single / Individuel					
	 Transport width Largeur de transport	255 cm. 8.4 ft.					
	 Transport length Longueur de transport	680 cm. 22.3 ft.	765 cm. 25.1 ft.	945 cm. 31 ft	680 cm. 22.3 ft	765 cm. 25.1 ft	945 cm. 31 ft
	 Street lights and signals Kit feux et signalisation routière	□	□	□	□	□	□
	 Hydraulic brake Frein hydraulique	-	-	-	-	-	-
	 Spare wheel kit Kit roue de secours	□	□	□	□	□	□
Hitch / Enganche	 Hydraulic connections required Connexions hydrauliques nécessaires	1SE + 1 DE					
	 Hitch Attelage	Trailed / Arrastrado			Semi-mounted / Semi-porté		
	 Self-steering system Système auto directionnel	-	-	-	•	•	•
	 Oscillating crossbar for lifter Traverse oscillante pour élévateur	-	-	-	•	•	•

• Standard / Standard □ Optional / En option - Not available / No disponible

EASY RAKE SUPERSTAR

ERS 16	ERS 18	ERS 20	ERS 22
940 cm. 30.8 ft.	1030 cm. 33.8 ft.	1120 cm. 36.7 ft.	1210 cm. 39.7 ft.
Hydraulic / <i>Hydraulique</i>			
100-140 cm. / 3.3-4.6 ft.			
Mechanical 4-positions / <i>Mécanique 4 positions</i>			
100 HP	100 HP	100 HP	100 HP
2400 kg 5291 Lbs.	3200 kg 7055 Lbs.	3400 kg 7495 Lbs.	3650 kg 8050 Lbs.
16	18	20	22
Tapered roller / <i>Rouleau conique</i>			
150 cm. / 4.9 ft.			
7,5 mm / 0,295"			
40 (18 each Rubberflex / 18 chaque Rubberflex)			
opt. n. 2, 95 cm / 3.1 ft. , HYD			
□	□	□	□
□	□	□	□
Hydraulic / <i>Hydraulique</i>			
Independent arms / <i>Bras indépendantes</i>			
Independent spring on each rake wheel / <i>Ressort indépendant sur chaque soleil</i>			
-	•	•	•
Rear frame / <i>Châssis arrière</i>			
•	•	•	•
4 195/65 R15	8 195/65 R15	8 195/65 R15	8 195/65 R15
□	□	□	□
8	12	12	12
n.8 opt. 195/65 R15	n.12 195/65 R15	n.12 195/65 R15	n.12 195/65 R15
Single / <i>Individuel</i>			
300 cm. 9.8 ft.			
1030 cm. 33.8 ft	1120 cm. 36.7 ft	1210 cm. 39.7 ft	1310 cm. 43 ft
□	□	□	□
□	□	□	□
□	□	□	□
1SE + 1 DE			
Semi-mounted / <i>Semi-porté</i>			
•	•	•	•
•	•	•	•



Our Range / Notre Gamme



HAYMAKING FENAISON



Mowers
Facheuses

Hay Tedders
Girofaneurs



Rotary Rakes
Giro-andaineurs

Hay Rakes
Rateaux soleil



Bale Wrappers
Enrubanneuses de balles



Rotary Tillers
Fraises Rotatives



Disc Cultivators
Cultivateurs à Disques



Fertilizers
Epandeurs d'engrais



Slurry Tankers
Tonnes à Lisier



FARM AGRICULTURE



Front Loaders
Chargeurs Frontaux



Backhoes
Pelles-Rétro



Rear Scraper Blades
Lames Niveleuse



IMPLEMENTS OUTILS

AGRICULTURAL MACHINERY
enorossi

Your Enorossi Dealer / Votre revendeur Enorossi



Via Cortonese, 36 - 06019 Calzolaro di Umbertide (PG) - ITALY
☎ +39 075 930 22 22 - 📠 +39 075 930 23 28

info@enorossi.it - www.enorossi.it