

STUMP
Grinders

Model R25HD

DOMINATOR

REIST
INDUSTRIES

MANUFACTURED IN CANADA



CONSTRUCTED FOR EFFICIENCY.

Reist Industries has been developing professional grade tools since the company was established in 1947. Each of our products has been thoughtfully engineered to provide industry leaders with tools they need to remain competitive in their markets. We believe that there is always room for improvement and we never stop innovating.

Our Dominator stump grinders bring a unique look to the market. We've ditched the traditional round rotor in favor of increasing performance with a more efficient design. The uniquely shaped rotor is **flange mounted** to the drive line allowing for easy removal when required for maintenance. Through optimized cutting tooth placement and shedding of unnecessary rotor material, Dominator Stump Grinders feature fast spin up and higher tip speeds. This design principle is central to both our PTO and hydraulic grinder models and allows them to power through the toughest stumps effortlessly.

Dominator grinders are available in two chassis configurations. The direct mount models are hinged at the top and are designed to travel in a linear motion inline with the power unit as it passes the grinder over the stump. Our swing arm models have a central pivot and the grinder is swung across the stump, Direct drive models rely on the stability of the power unit and are better suited for smaller diameter stumps, whereas the swing units have stabilizing feet integrated into their mounts and handle wider stumps with ease.

CARBIDE TEETH



Dominator stump grinders use Wearsharp® teeth. The round design of the tooth and a triangular base allows it to be indexed 3 times for extended life.

CIRCULAR PATH OF ROTOR/OFFSET DOUBLE TEETH

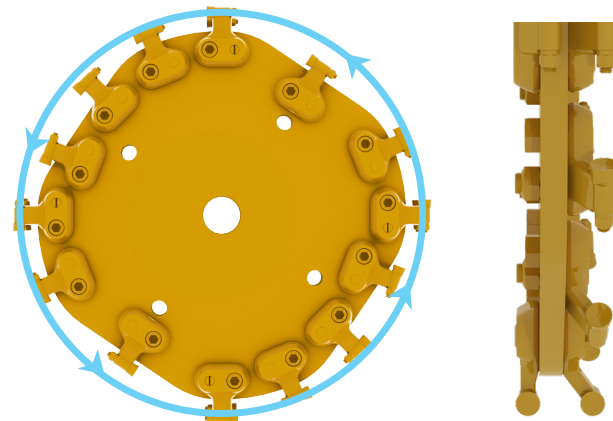

Optimization of teeth placement and the shedding of unnecessary rotor material, Dominator Stump Grinders feature faster spin up speeds and higher tip speeds.

RECOMENDED APPLICATIONS

A perfect fit for any power unit, Dominator grinders are available in a variety of configurations making them as home on the PTO of your tractors 3PH as they are leading the charge from the hydraulics on both your mini and full size skid loaders.

Models	Small Acreage	Rental Shops	Landscaping/Arborist	Ideal Stump Sizes
Direct Drive (PTO)				
R25PD				12"
R25PSS				12"
R25PSV				24"
Hydraulic Drive				
R18HD				9"
R25HD				12"
R25HS				24"

SWING DISTANCE

Dominator swing-type stump grinders enhance operator efficiency with their extended reach, making them well-suited for large-diameter stumps. Their design minimizes the need for frequent repositioning, making them an excellent choice for minimizing turf damage.



PTO DRIVE MODELS **R25PSS & R25PSV**

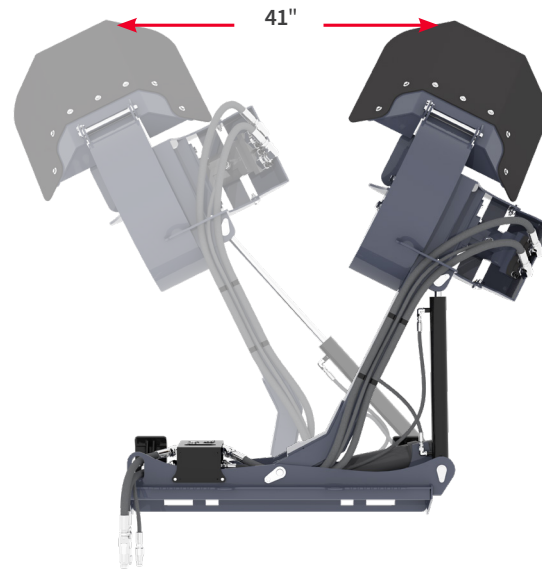

HYDRAULIC MODEL **R25HS**



Model R25PD

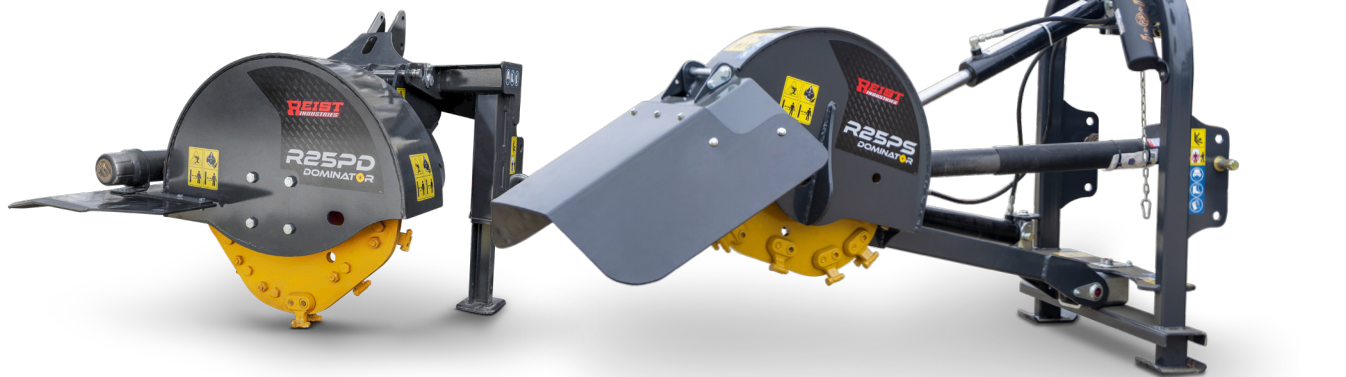

Model R25PD

Model R25PSV

R25PD PTO Direct Drive

The **R25PD** Dominator is a PTO direct drive stump grinder with a 25" rotor. An offset pin allows the unit to pivot off axis under its own weight providing a natural sweep motion as the tractor incrementally moves forward.

The **R25PD** easily mounts to any Cat I 3PH hitch and is quick hitch compatible. Park stands keep the unit in the upright position ensuring easy hookup.

R25PSS/R25PSV PTO Swing Type

R25PS swing arm models, utilize a 25" rotor optimized to cut in one direction. Equipped with an adjustable flow control, the return speed of the arm can be adjusted to suit any operating condition or operators experience level.

The **R25PSS** requires two remotes, one to adjust the height of the arm and one to swing it along its 55 degree arc. For tractors with only one remote, the **R25PSV** adds a valve on an ergonomically adjustable arm to control the hydraulic functions.

Compatible with Cat I & II 3PH's, Dominator stump grinders are also compatible with Quick Hitches. The frame incorporates two pads which provide firm footing on uneven ground eliminating deflection of the frame.

STUMP GRINDERS

PTO Models

Direct Drive Models	R25PD	R25PSS	R25PSV
Recommended PTO HP	20-45 HP	25-80 HP	25-80 HP
PTO (input speed)	540 RPM	540 RPM	540 RPM
Rotor Size	25"	25"	25"
Rotor Thickness	3/4"		
Tooth Construction	CARBIDE BOLT INTO POCKET (Indexable 3x)		
Number of teeth	18	18	18
Cutting Wheel Speed	540 RPM	1,026 RPM	1,026 RPM
Cutting Height (above grade)	10"	20"	20"
Cutting Height (below grade)	7"	6"	6"
Cutting Depth (per pass)	2.25"	2.25"	2.25"
Cutting Width (per pass)	22"	22"	22"
Swing Distance	0	45"	45"
Protection	SLIP CLUTCH		
Hitch	CAT I	CAT I & II	CAT I & II
Quick Hitch Compatible	YES	YES	YES
Hydraulic Remotes Required	0	2	1
Hydraulic Valve	N/A	N/A	YES
Weight (shipping)	460 LBS.	950 LBS.	950 LBS.
Length (shipping)	30"	42"	42"
Width (shipping)	38"	72"	72"

HYDRAULIC VALVE (R25PSV)

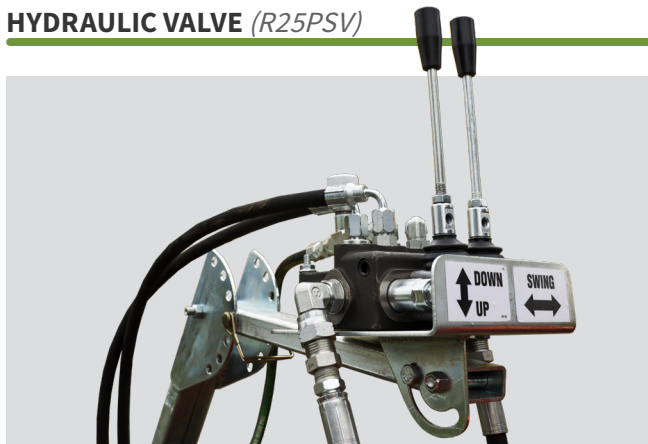

The addition of an optional valve on an ergonomically adjustable arm, provides both lift and swing functions for tractors with one hydraulic remote.

HDPE DEFLECTOR (ALL MODELS)



Made with high density polyethylene, the deflector stands up to abuse regardless of the air temperature all while containing debris from the stump.

GEAR BOX (R25PSS & R25PSV)



Three Point Hitch swing type grinders utilize 1:1.9 ratio gear box accelerating the flange mounted rotor to 1,026 RPMs.

CUTTING DEPTH GAUGE (SWING MODEL)



An easy to read gauge helps operators determine the cutting depth.



Model R25HS



Model R18HD

R18HD

Hydraulic Direct/Compact

The **R18HD** brings high performance stump grinding to compact power units. With an 18" grinding rotor measuring 1/2" thick.

Available with 2 motor options to match your hydraulic requirements the **R18HD** can be packaged with one of 3 available mounts making it ideal for today's mini and universal skid steers.



Model R25HD

R25HD

Hydraulic Direct

Increase your capability of your skid steer with the Dominator **R25HD**. This hydraulic direct drive stump grinder features a 25" rotor measuring 3/4" thick.



Model R25HS

R25HS

Hydraulic Swing Type

Get into the swing of things with the Dominator **R25HS**. This swing type grinder has 41" of travel.

The adjustable stabilizing feet ensure that the unit is stable during swing movement. This unit also features a 25" rotor measuring 3/4" thick.



When equipped with the 90CC Bent Axis Piston Motor, the **R25HD** and **R25HS** can handle 27-38 GPM to give you that extra grinding power.

STUMP GRINDERS

Hydraulic Drive Models

Hydraulic Drive Models	R18HD	R25HD	R25HS
Rotor Size	18"	25"	25"
Rotor Thickness	1/2"	3/4"	3/4"
Tooth Construction	CARBIDE BOLT INTO POCKET (Indexable 3x)		
Number of teeth	10	18	18
Bi-Directional Wheel	N/A	N/A	OPTIONAL
Cutting Wheel Speed	1450-2180 RPM	1135-1590 RPM	1135-1590 RPM
Cutting Depth (below grade)	4.5"	7"	7"
Cutting Depth Max. (per pass)	2.25"	2.25"	2.25"
Swing Arc	-	-	41"
Hydraulic Remotes Required	1	1	1
Case Drain Req.	YES	YES	YES
Weight (shipping)	240 LBS.	480-500 LBS.	670 LBS.
Length (shipping)	37"	41"	83"
Width (shipping)	36"	47"	47"



HYDRAULIC CONFIGURATIONS

For optimal performance hydraulic grinders should be matched to the GPM output of the power unit.

Hydraulic Models	Rotor dia	Style	Hitch Type	Flow Controlled *	Motor	GPM
R18HD						
R18HDMB1015G	18"	DIRECT	MINI BOBCAT	NO	26CC GEAR MOTOR	10 TO 15
R18HDMS1015G	18"	DIRECT	MINI SKID STEER	NO	26CC GEAR MOTOR	10 TO 15
R18HDSK1520G	18"	DIRECT	UNIVERSAL SKID STEER	YES	39CC GEAR MOTOR	15 TO 20
R25HD						
R25HDSK1620G	25"	DIRECT	UNIVERSAL SKID STEER	YES	50CC GEAR MOTOR	16 TO 20
R25HDSK2026G	25"	DIRECT	UNIVERSAL SKID STEER	YES	63CC GEAR MOTOR	20 TO 26
R25HDSK2738P	25"	DIRECT	UNIVERSAL SKID STEER	NO	90CC BENT AXIS PISTON MOTOR	27 TO 38
R25HS						
R25HSSK1620G	25"	SWING	UNIVERSAL SKID STEER	YES	50CC GEAR MOTOR	16 TO 20
R25HSSK2026G	25"	SWING	UNIVERSAL SKID STEER	YES	63CC GEAR MOTOR	20 TO 26
R25HSSK2738P	25"	SWING	UNIVERSAL SKID STEER	NO	90CC BENT AXIS PISTON MOTOR	27 TO 38
Wiring Harness	CONSULT PRICE BOOK FOR WIRING HARNESSES STARTING WITH EWKD****					

* Refers to the units speed protection. Can't over speed unit.

STUMP GRINDER

Options



DEBRIS SCREEN

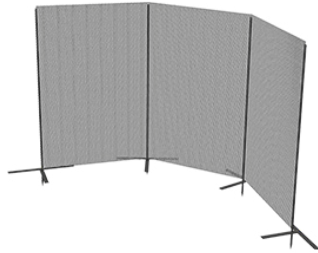

- 10' wide by 5' tall
- Includes 4 posts with integrated ground spikes
- Contain stump grinder debris

HITCH EXTENSIONS



- Increases distance between tractor and stump grinder
- For use with R25PD only

BI-DIRECTIONAL CUTTING

Hydraulic swing type model grinders can be configured to cut in both directions when outfitted with an optional bi-directional cutting tooth layout.

OPTIONAL HOSE PROTECTOR SHIELDS (HYDRAULIC MODELS)

- Increases protection to hose and motor assembly



R18HD



R25HD

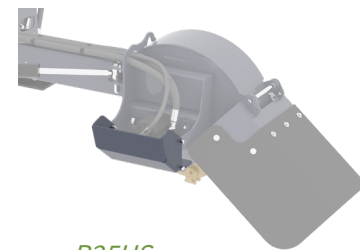

R25HS

Reist Industries
100 Union Street
Elmira, Ontario, Canada
N3B 3L7

Phone: 519-669-1501
Fax: 519-669-3021
Toll Free: 1-877-467-3478
www.reistindustries.com