

DION

-Ag Inc.

SCORPION

300



Operator's Manual

FORAGE HARVESTER

Manual no. F6921E027E

V1.0

FOREWORD

We thank you for your confidence towards DION-Ag Inc. agricultural equipment. We have prepared this manual with care and attention and have designed it as an essential tool that will allow you to use and maintain your machine adequately and safely. By following the instructions that it contains, you will obtain optimal performance and durability of the harvester for years to come.

Carefully read this manual in order to familiarize yourself with the adjustment procedures and operation, before attempting to use the machine. Keep in mind this machine has been designed and tested to perform in most conditions. However, its performance is tightly linked to the maintenance it receives.

Any equipment requires a minimum amount of service and repair to be kept in good working condition. We have attempted to cover most of the required adjustments for the different possible field conditions. However, some unique cases might require special adjustments. Contact your dealership for any support or information. They will assist you with the purchase of replacement parts and will be able to provide qualified technicians to repair, maintain and adjust your machine.

This manual has been prepared with the latest available information at the time of publishing. The company reserves the right to make any changes without prior notice.

SAFETY

The Safety section of your Operator's manual is intended to point out some of the basic safety situations which may be encountered during normal operation and maintenance of your Forage Harvester, and to suggest possible ways of dealing with these situations. This section is NOT a replacement for other safety practices featured in other sections of this manual.

The safety of the operator is one of the main concerns in designing and developing a new Forage Harvester. Designers build in as many safety features as possible. However, every year accidents may occur which could have been avoided by a few seconds thought and a more careful approach to handling farm machinery and implements.

Read and implement the safety instructions detailed within and share them with other operators.

WARRANTY INFORMATION

You will find the warranty information for this machine at the beginning of this manual. **The warranty information shall be filled out and signed by all parties and the appropriate copies sent to the 3 parties as indicated at the bottom of each page.** Failure to submit this information to DION-Ag Inc. may affect the warranty duration.

IMPORTANT: THIS MANUAL MUST REMAIN WITH THE MACHINE IF SOLD.

DION-AG INC. LIMITED WARRANTY

TERMS AND CONDITIONS

Covered by Warranty – Under the warranty, DION-Ag Inc. guarantees its new machinery and/or equipment to be free of defects, both in workmanship and material, for a period of one (1) year from the time of delivery by the dealer to the owner. DION-Ag Inc. will repair or replace, at its discretion and without charge for service parts or labour, any defective part of the equipment on condition that the machinery and/or equipment has been operated in accordance with the instructions contained in the DION-Ag Inc. Operator's Manual provided the warranty form is submitted to DION-Ag Inc., in full, as mentioned in the afore Warranty Information section.

Not covered by Warranty – This warranty does not cover: (1) service parts and labour needed to maintain the unit; and (2) the replacement of parts due to normal wear and tear. The owner is responsible for these items. Some examples of maintenance and normal wear parts are: oil, lubricants & other fluids, belts, knives, clutch and clutch discs, roller chain, paddles, etc. DION-Ag Inc. is not responsible for depreciation or damage caused by normal wear, lack of reasonable and proper maintenance, failure to follow operating instructions, misuse, lack of proper protection during storage, vandalism, the elements, collision or accident. (3) Using the forage harvester with a header from another manufacturer will void warranty on all driveline components. Any other damage caused to the harvester by this header will not be covered.

Securing Warranty Service – To secure warranty service, the owner must report the machinery and/or equipment defect to an authorized dealer and request warranty service within the applicable warranty term.

Owner's Obligation – It is the responsibility of the Owner to transport the equipment to the service shop of an authorized DION-Ag Inc. Dealer or to reimburse the dealer for any travel or transportation expense involved in fulfilling this warranty. This warranty does NOT cover rental of replacement equipment during the repair period, loss of profits, or other commercial loss, and any or all incidental or consequential damages, overtime labour charges and/or freight charges for replacement parts.

Limitations of This Warranty – No agent, employee or representative of DION-Ag Inc. has the authority to amend, or modify, in any manner whatsoever, the terms of the present warranty. The express warranties herein contained exclude all other express, implied or statutory warranties. THIS WARRANTY IS IN LIEU OF ALL OTHER WARRANTIES INCLUDING THE WARRANTIES OF MERCHANTABILITY AND/OR FITNESS FOR ANY PARTICULAR PURPOSE.

Right to Inspect – DION-Ag Inc. and its authorized agents reserve the right to inspect the owner's DION-Ag Inc. product to determine if a defect in material or workmanship exists prior the commencement of any covered repairs. It is the owner's responsibility to ensure availability and/or delivery of the product to DION-Ag Inc. for the purpose of inspection.

Right to Make Design Changes – DION-Ag Inc. reserves the right to make changes in the design and other changes in its products at any time and from time to time without notice and without incurring any obligation of its part to modify, improve or add to products previously ordered from DION-Ag Inc. And sold or shipped by DION-Ag Inc.

Liability – DION-Ag Inc. shall not be liable, if, during the use of the machinery and/or attachment, the security guards have been removed, modified, or have not been properly maintained.

Metal Detector Warranty – Due to its limitations, the metal detector cannot and should not be considered as an infallible system. THE WARRANTY DOES NOT COVER INCIDENTAL OR INDIRECT DAMAGES.

The Warranty shall not apply if the instructions mentioned in this manual have not been followed completely and correctly. Nor will the warranty apply if the owner or any third party modifies the machine without DION-Ag Inc.'s knowledge and/or authorization. Every owner, when buying a DION-Ag Inc. machine, agrees and undertakes to use and operate the machinery and its component parts safely, and in accordance with all applicable laws, and in accordance with the Operator's Manual. Furthermore, the owner agrees and accepts to indemnify and hold harmless DION-Ag Inc. for all losses and damages to any person or property resulting from the owner's non-compliance with the terms and conditions of this warranty. Each owner further agrees to bring the warranty to the attention of any subsequent owner, and to obtain agreement therein as a condition of resale or transfer.

January 1st 2019

TABLE OF CONTENTS

FOREWORD	3
SAFETY	3
WARRANTY INFORMATION	3
DION-AG INC. LIMITED WARRANTY	4
SPECIFICATIONS	9
DIMENSIONS.....	9
WEIGHT	9
TRANSMISSIONS	9
CUTTER HEAD	9
TIRES AND WHEELS.....	10
FEATURES	10
SERIAL NUMBER LOCATION	11
SAFETY RULES	12
A WORD TO THE OPERATOR	12
CODES AND SYMBOLS.....	12
FOLLOW A SAFETY PROGRAM.....	12
GENERAL SAFETY RULES	13
PTO OPERATION	13
PREPARATION AND OPERATION	14
MANDATORY STOPPING PROCEDURE	14
INSPECTION, MAINTENANCE AND ADJUSTMENTS	15
TRANSPORT AND STORAGE	15
GUARDS AND SHIELDS	16
SAFETY SIGN LOCATION	17
SETUP	22
BOLT TORQUE SPECIFICATIONS	22
MANUAL JACK.....	23
12V POWER CONNECTION	23
CONTROL BOX INSTALLATION.....	24
HYDRAULIC CONNECTION	24
CONNECTING THE HARVESTER TO THE TRACTOR	25
DRAW BAR EXTENSION	27
CONFIGURING FOR CORN HARVEST SETUP	29
CONFIGURING THE HARVESTER FOR WINDROW (HAY) HARVESTING	36
SETTING THE LENGTH OF CUT.....	43
PROCEDURE TO MODIFY THE LENGTH OF CUT	44
SPOUT EXTENSION REMOVAL.....	45
HEADER INSTALLATION.....	47
HEADER SUSPENSION	50
HEADER HEIGHT ADJUSTMENT	51
STARTING UP AND BREAK-IN	51
KNIVES AND SHEAR BAR	51
SHEAR BAR DESIGN	52
KNIFE SHARPENING	53
DAILY SHEAR BAR ADJUSTMENT	54
CONTROL BOX FUNCTIONS.....	55
METAL DETECTOR GENERAL INFORMATION	56
DAILY CHECKS ON THE METAL DETECTOR.....	57
METAL DETECTOR SENSITIVITY AJUSTEMENT.....	58
DISABLING THE METAL DETECTOR.....	59
DRIVE FAILURE DETECTOR	60
DISABLING THE DRIVE FAILURE DETECTOR	61

LIQUID INCORPORATION SYSTEM.....	62
<i>PRESSURE ADJUSTEMENT</i>	62
<i>FLOW CALIBRATION PROCEDURE</i>	63
TRANSPORT LIGHTS	64
SET TRACK WIDTH.....	65
GROUND CLEARANCE	65
OPERATION PRACTICAL ADVICE.....	66
<i>HARVESTER DRAW BAR POSITION</i>	66
STOPPING THE MACHINE.....	66
FIELD WORK	66
F-N-R TRANSMISSION SHIFTING	68
<i>WITHOUT METAL DETECTOR, OR DEACTIVATED</i>	68
<i>WITH METAL DETECTOR</i>	68
INITIALIZING THE METAL DETECTOR.....	69
STARTING UP	69
STOPPING THE HARVESTER.....	69
METAL DETECTION PROCEDURE.....	70
PROCESSOR ROLL PRESSURE AND SPACING	70
PROCESSOR ROLL CLEARANCE ADJUSTMENT PROCEDURE	71
HEADER OR FEED ROLL OVERLOAD.....	71
SHEAR BOLT FAILURE	72
FRICTION CLUTCH (OPTIONAL)	73
CLEANING THE PROCESSOR ROLLS	73
TRANSPORT	74
HYDRAULIC CIRCUITS.....	76
POWER TAKE OFF (PTO).....	76
DRIVE CHAINS	76
LUBRICATION CHART	77
GEARBOXES LUBRICATION.....	77
PROCESSOR ROLL LUBRICATION	84
SMOOTH FEED ROLL SCRAPER ADJUSTMENT	87
KNIFE ADJUSTMENT.....	88
KNIFE REPLACEMENT.....	89
SHEAR BAR REPLACEMENT	90
SHEAR BAR INITIAL ADJUSTMENT.....	92
SHEAR BAR CLAMPING ADJUSTMENT.....	93
CUTTERHEAD LINER REPLACEMENT	95
PROCESSOR LINER ADJUSTMENT.....	96
PROCESSOR MINIMUM GAP ADJUSTMENT	98
ACCELERATOR LINER REPLACEMENT	99
ACCELERATOR ADJUSTMENT.....	100
ACCELERATOR PADDLE REPLACEMENT AND BALANCING	101
SPOUT ROTATION MOTOR AND GEAR ADJUSTMENT	102
SPOUT CYLINDER TRAVEL SENSOR ADJUSTMENT	103
SPOUT LINER REPLACEMENT	104
FEED ROLL SPRING TENSION	105
HARVESTING UNDER SPECIAL CONDITIONS.....	105
FEED ROLLS CHAIN TENSION	106
TRANSMISSION BELT TENSION	107
ACCELERATOR BELT TENSION	108
PROCESSOR BELTS TENSION	108
HEADER LIFT CYLINDER ADJUSTMENT	109
STONE CARRIAGE ADJUSTMENT	110
SHARPENING STONE REPLACEMENT	111
SHARPENER FRAME ADJUSTMENT	111
F-N-R TRANSMISSION SHIFTER ARM ADJUSTMENT	112

F-N-R TRANSMISSION SENSOR ADJUSTMENT.....	113
FEED ROLL STOPPING MECHANISM ADJUSTMENT	114
SPEED SENSOR ADJUSTMENT	115
ELECTRONIC CONTROL UNIT & CONNECTOR CLEANLINESS.....	116
WELDING ON THE HARVESTER.....	116
STORAGE PROCEDURE.....	117
DIAGNOSTICS & TROUBLESHOOTING	119
CONTROLLER ALARMS AND LOGIC	119
TRANSMISSION SHIFTER LOGIC	120
CONTROL BOX, TRANSMISSION AND METAL DETECTOR	121
EJECTION	124
FEEDING.....	125
LIQUID INCORPORATION SYSTEM.....	125
CUTTING	126
PROCESSOR ROLLS.....	126
DRIVE	127
ELECTRO-HYDRAULIC FUNCTIONS.....	128
CHECKLIST	138

SPECIFICATIONS

Specification and design are subject to change without notice and responsibility from the manufacturer.

DIMENSIONS

OVERALL width (narrow axle position)

- With tires 31x13.50 - 15 TerraRib.....3.30 m (142")
- With tires 31x15.50 - 15 TerraTrac.....3.50 m (150")

LENGTH (Spout in transport position)6.22 m (244")

HEIGHT min / max – (Wheels in standard position)

- Standard spout – lowered/lifted.....2,79 m / 3.44 m (110"/140")
- 'Stinger' spout – lowered/lifted.....2,79 m / 5.38 m (110"/212")

WEIGHT

Standard equipment – tandem axle, Metal detector, short spout2860 kg (6300 lb)

- Processor rolls.....+300 kg (660 lb)
- 'Stinger' spout.....+110 kg (230 lb)

TRANSMISSIONS

ANGLE DRIVE CONFIGURATIONS

- 1000/800: 1000 rpm PTO - 815 rpm at the cutter head - 90 to 180 hp
- 1000/1000: 1000 rpm PTO - 1033 rpm at the cutter head - 160 to 300 hp

OIL CAPACITY

- 8 litres – Synthetic 80W140

MAIN GEARBOX FEATURES

- Reverse, Neutral, Forward position (R-N-F)
- Electro-hydraulic shifter
- Torque limiter
- 2 length of cut ranges (LOC pulley - factory installed)
- 3 length of cut (cut sprockets)

OIL CAPACITY

- 4 litres – Synthetic 80W140

CUTTER HEAD

- Width:.....610mm (24")
- Diameter:.....560mm (22")
- Rotation speed:.....810, 815 or 1033 rpm

SPECIFICATIONS

TIRES AND WHEELS

SINGLES

- 31, 13.5-15 TerraRib
- 31 x 15.5 TerraTrac

TANDEM

- 31, 13.5-15 TerraRib
- 31 x 15.5 TerraTrac

FEATURES

STANDARD

- Angle drive 1000/1000
- Cutter head with 8 tungsten carbide knives
- Built-in grinder
- One-side sharpening and shear bar adjustment (Performed on the ground)
- Fully electro-hydraulic functions
- Three length of cut sprockets 17T, 26T, 34T
- Height adjustable spout with 310° rotation
- Feed roll grain pan
- Adjustable drawbar Cat. II to IV

OPTIONAL

- Angle drive 1000/800
- 12 knife cutter head (12 knife cutter head (LOC from 4 to 24 mm possible)
- Spout extensions
 - Vertical extension 600 mm (24")
 - Horizontal extension 1.50 m (60")
 - 'Stinger' Extension 4.0m (157") – Includes LED spout light and wireless camera
- Single or tandem axles
- Quick trailer disconnect
- Metal detector and emergency stop via ultra-fast logic control
- Liquid incorporation system
 - Single or double supplementary tanks
- Corn processor rolls
- Drawbar extension
- Two length of cut ranges « LOC L » and « LOC H »

SPECIFICATIONS

SERIAL NUMBER LOCATION

For your convenience, write down the full model and serial number of your machine in this manual, as shown on the name plate illustrated below. Always mention both the model and the serial number when ordering parts or regarding any other correspondence with your machine.

Write down your number here:

MODEL NO.: _____ SERIAL NUMBER: _____

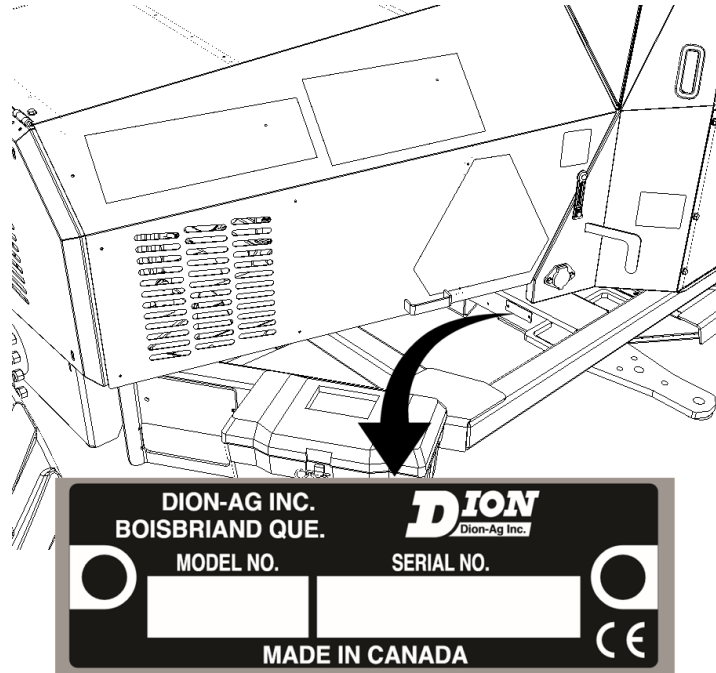

Figure 1 Serial number

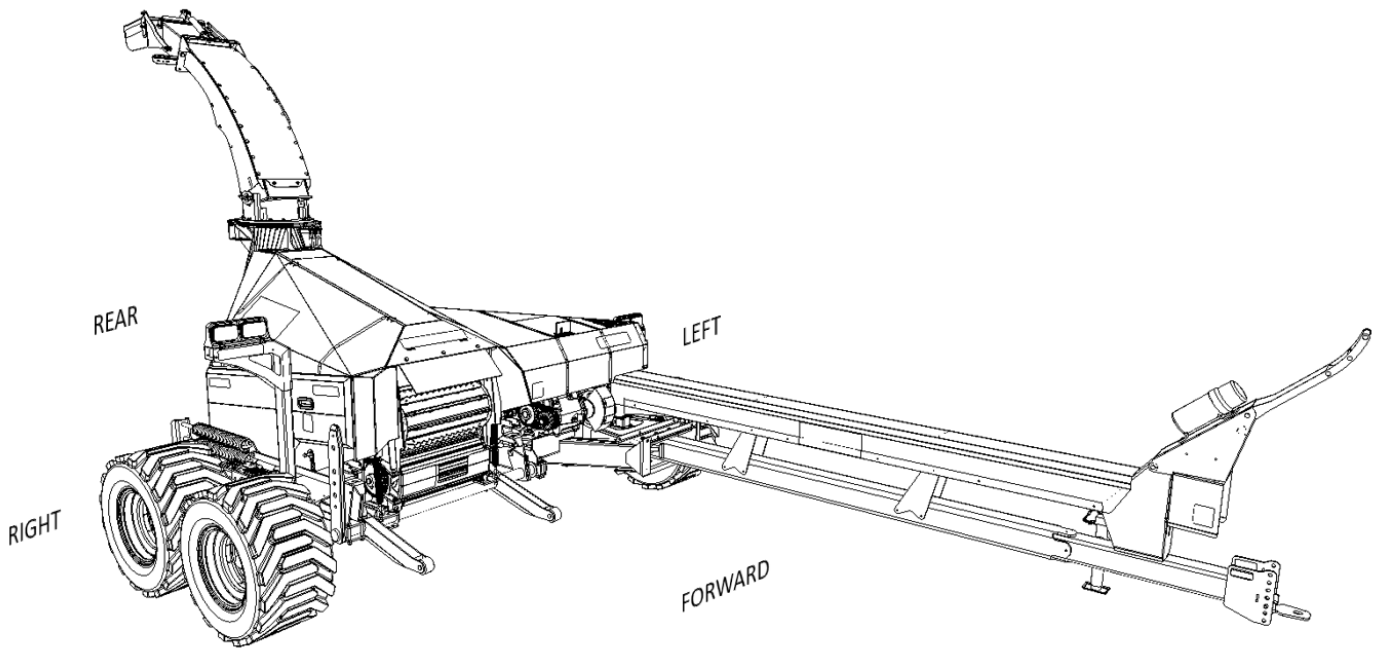

Figure 2 Machine orientation

SAFETY RULES

A WORD TO THE OPERATOR

It is the responsibility of the OWNER to read and fully understand the safety section in this manual before operating your tractor. You must follow these safety instructions that will assist you step by step throughout your workday.

After reading this section, you will note that illustrations have been used to highlight certain situations. Each illustration is numbered and the same number appears in the text in parenthesis.

Remember that YOU are the key to safety. Good safety practices not only protect you, but also the people around you. Study the features in this manual and make them a working part of your safety program.

Think SAFETY! Work SAFELY!

CODES AND SYMBOLS

The symbol below calls attention to instructions concerning your personal safety. It is found throughout the manual as well as on the machine to point out specific hazards and ways to avoid these hazards. Always follow the instructions to minimize the risk of personal injury or death.

SAFETY SYMBOL



DANGER, WARNING AND CAUTION

Whenever you see the words and symbols shown below or used in this manual and on decals, you MUST take note of their instructions as they relate to personal safety.



DANGER: This symbol together with the word DANGER indicates an imminently hazardous situation that, if not avoided, will result in DEATH OR VERY SERIOUS INJURY.



WARNING: This symbol together with the word WARNING indicates a potentially hazardous situation that, if not avoided, could result in DEATH OR SERIOUS INJURY.



CAUTION: This symbol together with the word CAUTION is used to indicate a potentially hazardous situation that, if not avoided, may result in MINOR INJURY.

IMPORTANT: The word **IMPORTANT** is used to identify special instructions or procedure which, if not strictly observed, could result in damage to, or destruction of the machine, process or its surroundings.

NOTE: The word **NOTE** is used to indicate points of particular interest for a more efficient and convenient service and operation of the machine.

FOLLOW A SAFETY PROGRAM

For safe operation of a Forage Harvester, you must be a qualified and authorized operator. To be qualified, you must read and understand the written instructions supplied in this Operator's Manual, have training, and know the safety rules and regulations for the job.

Some regulations specify that no one under the age of 16 years, for example, may operate power machinery. This includes tractors. It is your responsibility to know what these regulations are, and obey them, in the operating area or situation.

These will include, but are not limited to, the following instructions for proper operation.

SAFETY RULES

GENERAL SAFETY RULES



CAUTION: In some of the illustrations used in this Operator's Manual, panels or guards may have been removed for clarity. Never operate the machine without these components in place.



CAUTION: An operator should not be under the influence of alcohol or drugs which can alter alertness or coordination. An operator on a prescription or "over the counter" drug needs to obtain the advice of a qualified person before operating a machine.



CAUTION: DO NOT remove or obscure Danger, Warning, Caution or Instruction Decals that are not legible or are missing. Replacement decals are available from your Dealer in the event of loss or damage. The actual location of these Safety Decals is illustrated on page SAFETY SIGN LOCATION, See SAFETY SIGN LOCATION.

- Wear appropriate clothing, safety boots or shoes.
- Keep children away from the machine at all time.
- Do not operate the machine when visibility is bad, or during night, in poor lighting.
- Do not allow anyone to ride on the machine at any time.
- The tractor ignition key must be removed every time the operator leaves the tractor.
- Keep hands and body out of hitch area when attaching towing vehicle.
- Carefully read the safety decals on the machine. If any are damaged, replace them immediately.

PTO OPERATION

- Before starting the tractor engine, make sure that the PTO driveline locking device is properly engaged onto both the tractor and equipment drive shafts. Secure the safety chain to the tractor frame.
- Never proceed to start the machine before making sure all driveline, machine and tractor shields are properly installed in place.
- Never wear loose clothing and keep people, especially children away from the driveline.
- The PTO driveline shields should turn freely, be well connected and be maintained in good condition.
- Do not connect a tractor with a PTO speed of 1000 RPM on a machine equipped with a 540 RPM drive.
- Do not connect a tractor with a PTO speed of 540 RPM on a machine equipped with a 1000 RPM drive.
- Keep a good distance away from a rotating driveline (approximately the distance greater to your height).
- Never step across any PTO driveline.
- Never use the PTO driveline as a step.

SAFETY RULES

PREPARATION AND OPERATION

- Before starting the tractor engine, make sure all guards, shields, and doors are in place and properly secured and check the machine thoroughly for possible loose parts or bolts. Make any necessary adjustments.
- Use a lift system with a minimum lifting capacity of 3000 lbs (1350 kg) to install a header on the forage harvester. Refer to the header specifications.
- Never operate a Forage Harvester without first having installed a header.
- If a feeding or throwing mechanism should become jammed, never attempt to unblock it or remove any material when the machine is in motion or while the tractor engine is running.
- Make sure all rotating parts are stopped and the tractor engine is turned OFF before cleaning the machine throat.
- Never stand underneath the forage harvester deflector or forage path when the machine is running. Keep the discharge spout toward the forage box.

MANDATORY STOPPING PROCEDURE

No matter what type of machine is being used, it is extremely hazardous to perform any kind of maintenance work while the machine is running. It could lead to serious injuries or even death. Before cleaning, adjusting or greasing the machine, the following procedure should be followed to stop the Forage Harvester:

1. Place the transmission in neutral.
2. Disengage the PTO from the tractor.
3. Switch off the forage harvester control box.
4. Switch off the oil flow (distribution valve).
5. Switch off the tractor engine.
6. Apply the tractor's safety brake.
7. Wait until all rotating parts have completely stopped.
8. Disconnect the PTO input shaft from the tractor's PTO.
9. Block all wheels.



DANGER: Rotating driveline contact may cause serious injury or death.

SAFETY RULES

INSPECTION, MAINTENANCE AND ADJUSTMENTS



WARNING: Hydraulic fluid under pressure can penetrate the skin or eyes and cause serious personal injury, blindness or death. Fluid leaks, under pressure, may not be visible. Use a piece of cardboard or wood to find leaks. DO NOT use your bare hand. Wear gloves and safety goggles for eye protection.



CAUTION: Hydraulic lines and components can become very hot in operation and cause burns. Wear gloves and safety goggles for eye protection.

- Never proceed to start the machine before making sure all driveline, machine and tractor shields are well installed and in place.
- Never lubricate or clean any part while the machine or tractor engine is running.
- Never attempt to check or adjust chains while the machine is running.
- Disengage the PTO and shut off engine before leaving the operator's seat for refueling, lubricating or adjusting the machine.
- When performing a metal detection test, stop the PTO, wait until all moving parts are stopped, then disconnect the PTO from the tractor.
- Securely block the wheels from moving before working on or under the machine.
- If necessary, to work under or close to moving parts that may crush or hit you, block their movement to make the working environment safe.
- Make sure that all wheel bolts are properly torqued.
- When knives are being readjusted, a piece of wood should be used to immobilize the cutting head.
- Always pick-up tools after performing any adjustment.

TRANSPORT AND STORAGE

- Maximum traveling speed of a forage harvester should not exceed 32 km/h (20 mph).
- Never pull a loaded wagon behind the harvester on the road.
- Always use a draw pin of sufficient capacity, with a safety clip, to connect the harvester to the tractor and the trailer to the harvester, for every trip on the road or in the field.
- Attach a safety chain of at least 20,000 lbs (9071 Kg) capacity for transportation.
- Always deactivate the hydraulic circuit of the harvester and turn off the control box before traveling on public roads.
- Ensure the spout is in lock position before traveling on the road.
- When driving on a public road, or on hilly land, make sure the 'Hitch Disconnect' red safety cap is covering the switch and install the locking pin in the stop pawl of the quick-disconnect hitch to prevent unlocking. This locking pin should also be used for the manual quick-disconnect hitch.
- Never disconnect a trailer on hilly land.
- Make sure to meet local regulations for excessive width on public roads.
- When storing or parking the harvester, always lower the header down to the ground.

SAFETY RULES

GUARDS AND SHIELDS

The Forage Harvester is equipped with guards and shields wherever accidents can occur. These guards and shields do not affect the performance of the machine. Refer to Figure 3 to identify these guards and their location to make sure they remain in place for a safe operation.

1. PTO shaft, cables and hose shield.
2. Transmission shaft guard.
3. Feed roll transmission pulley guard.
4. Main guard covering the power transmission components.
5. Left « Butterfly guard » covering the processing element drive.
6. Right « Butterfly guard » covering the processing and sharpening elements.
7. Side guard covering the feed rolls and processor roll drive elements.

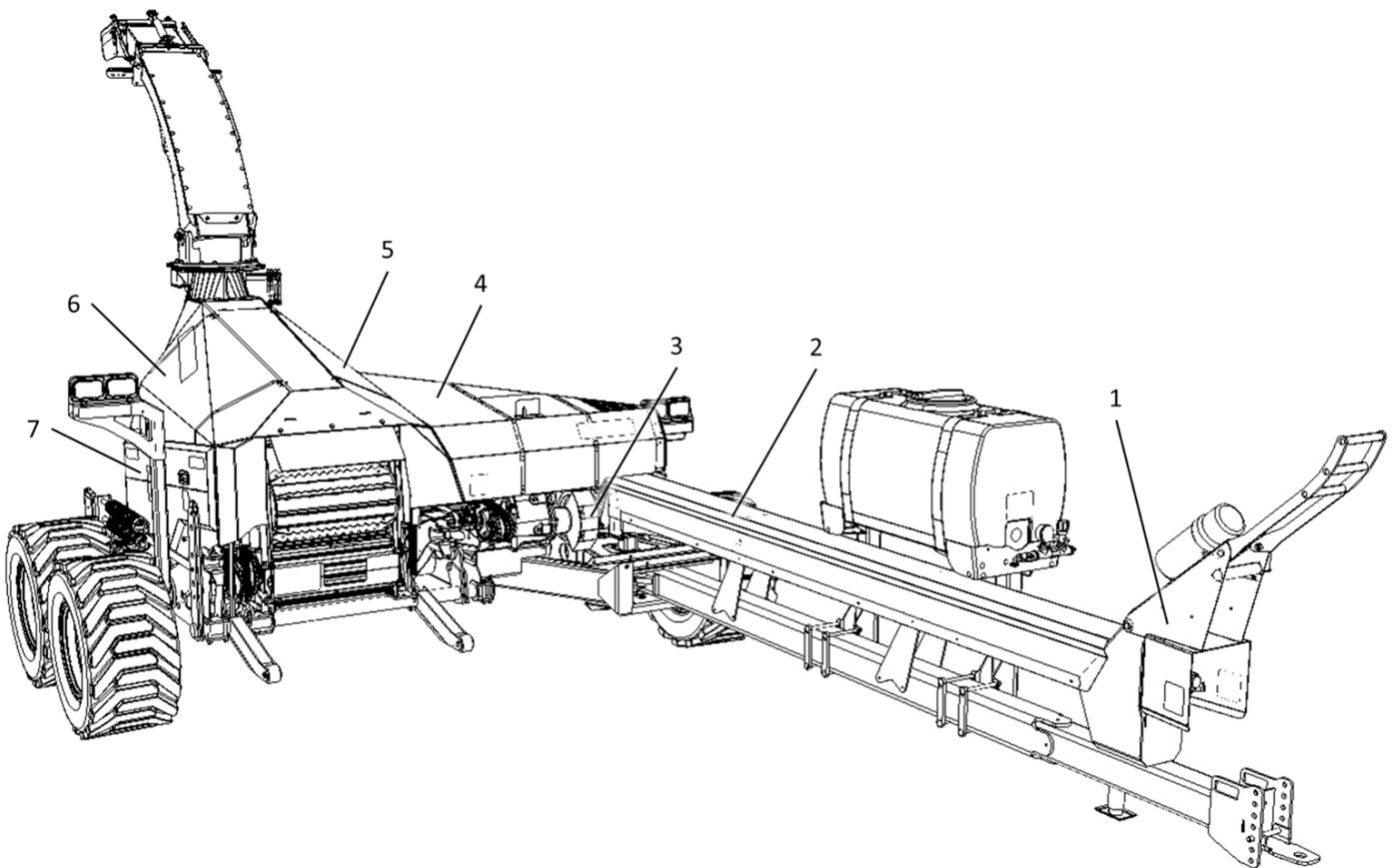

Figure 3 Location of the main guards



WARNING: All factory installed guards and shields should be in place and maintained in good condition.

SAFETY RULES

SAFETY SIGN LOCATION

Several decals located around the hazard areas indicate the potential dangers.

IMPORTANT: Decals must be kept clean to allow for visibility at all times.

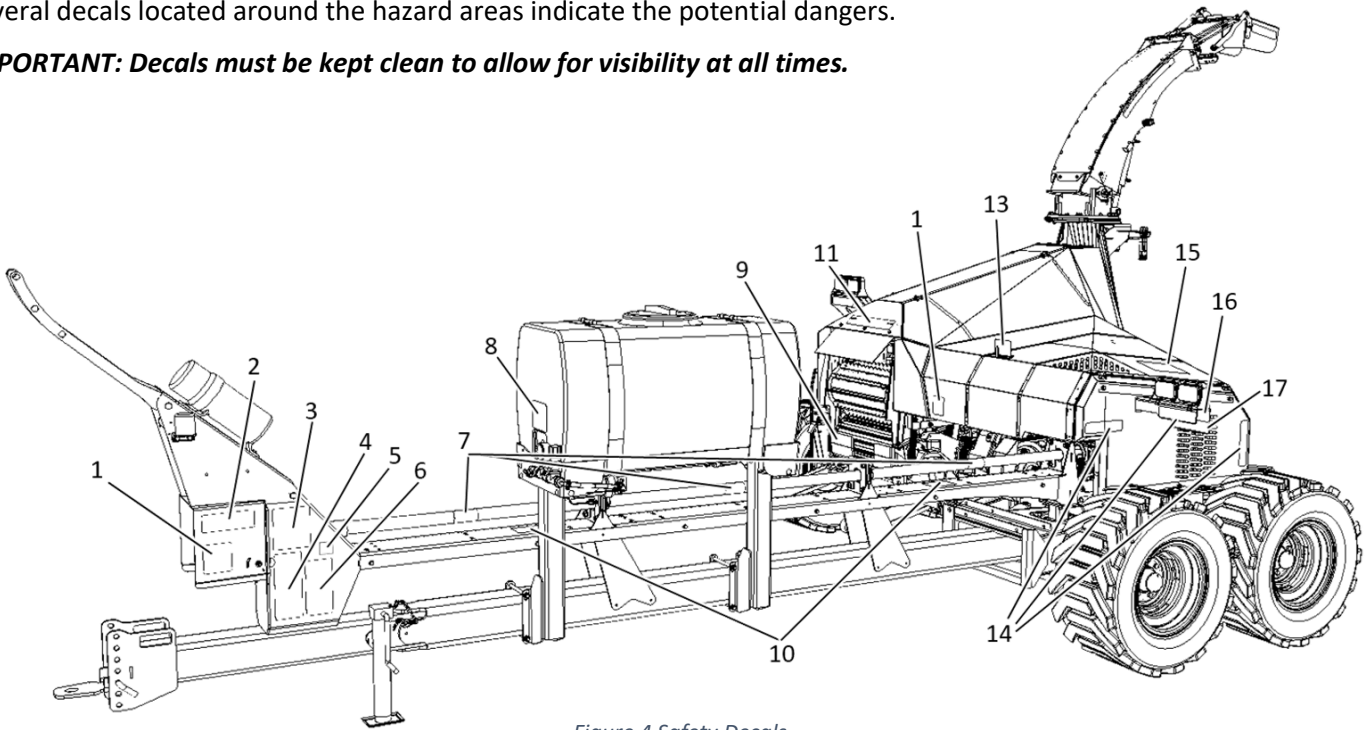

Figure 4 Safety Decals

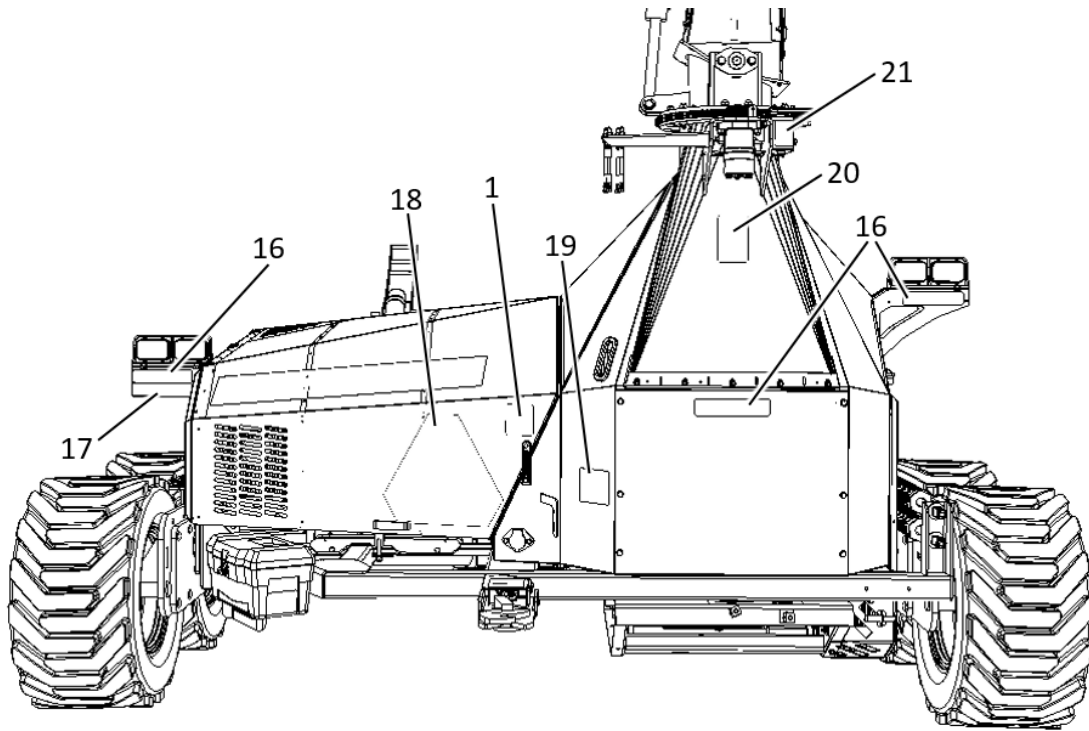

Figure 5 Safety Decals

SAFETY RULES

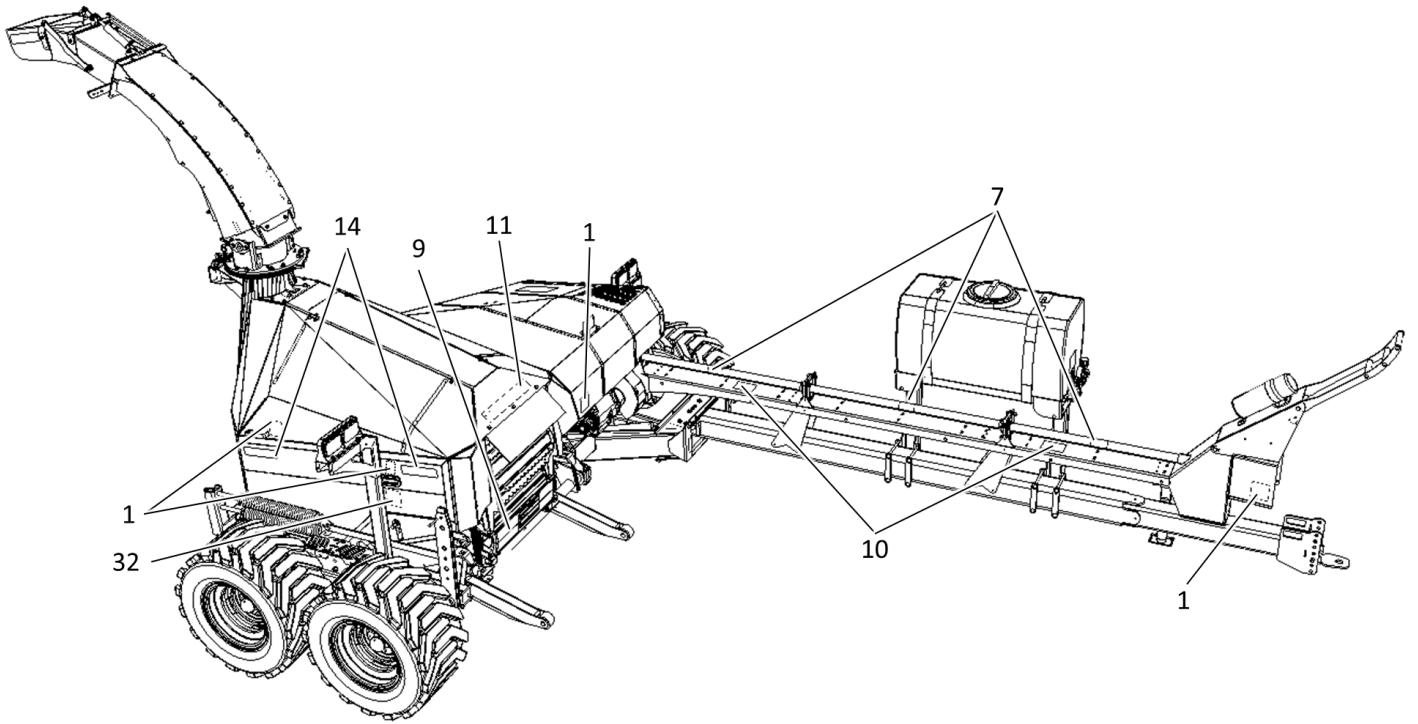

Figure 6 Safety Decals

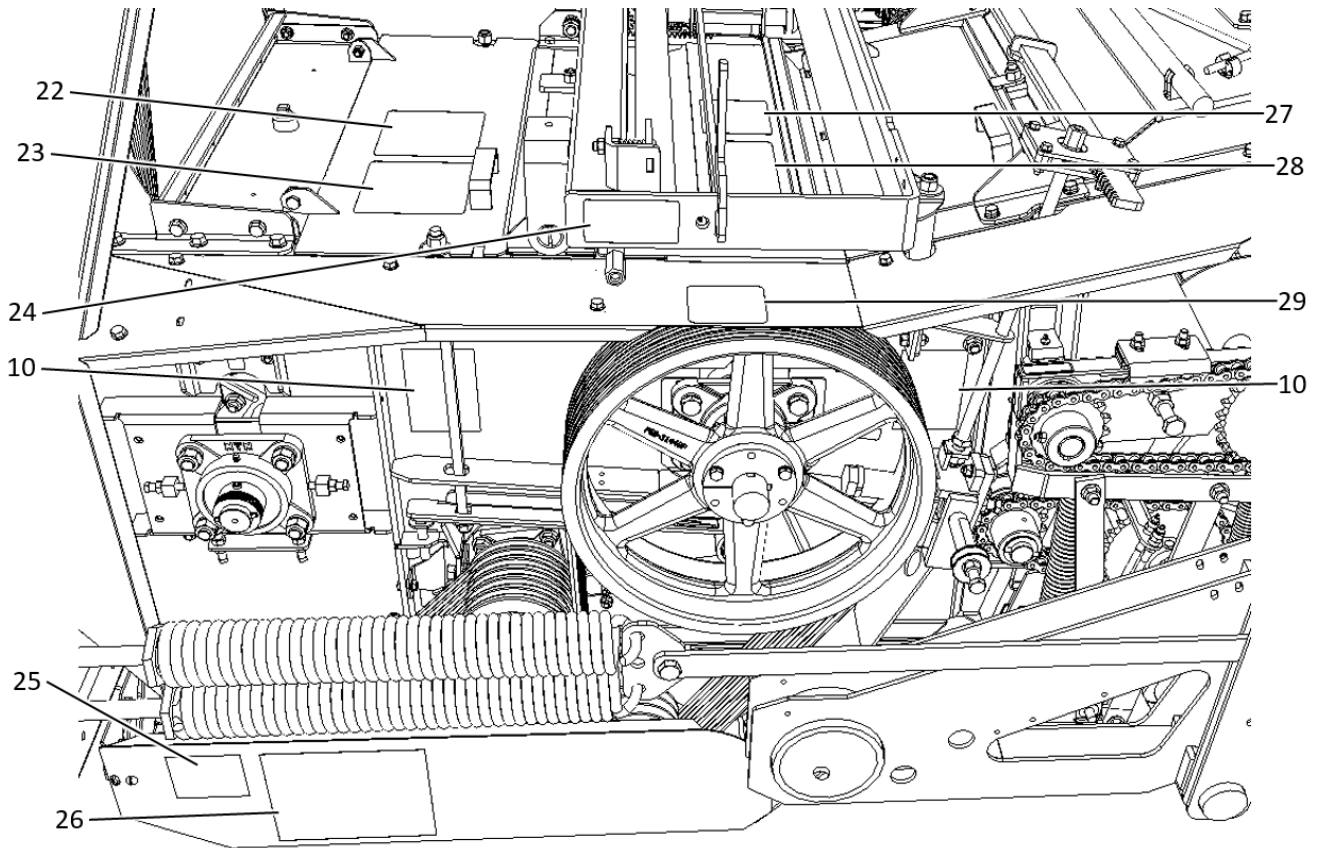

Figure 7 Safety Decals

SAFETY RULES

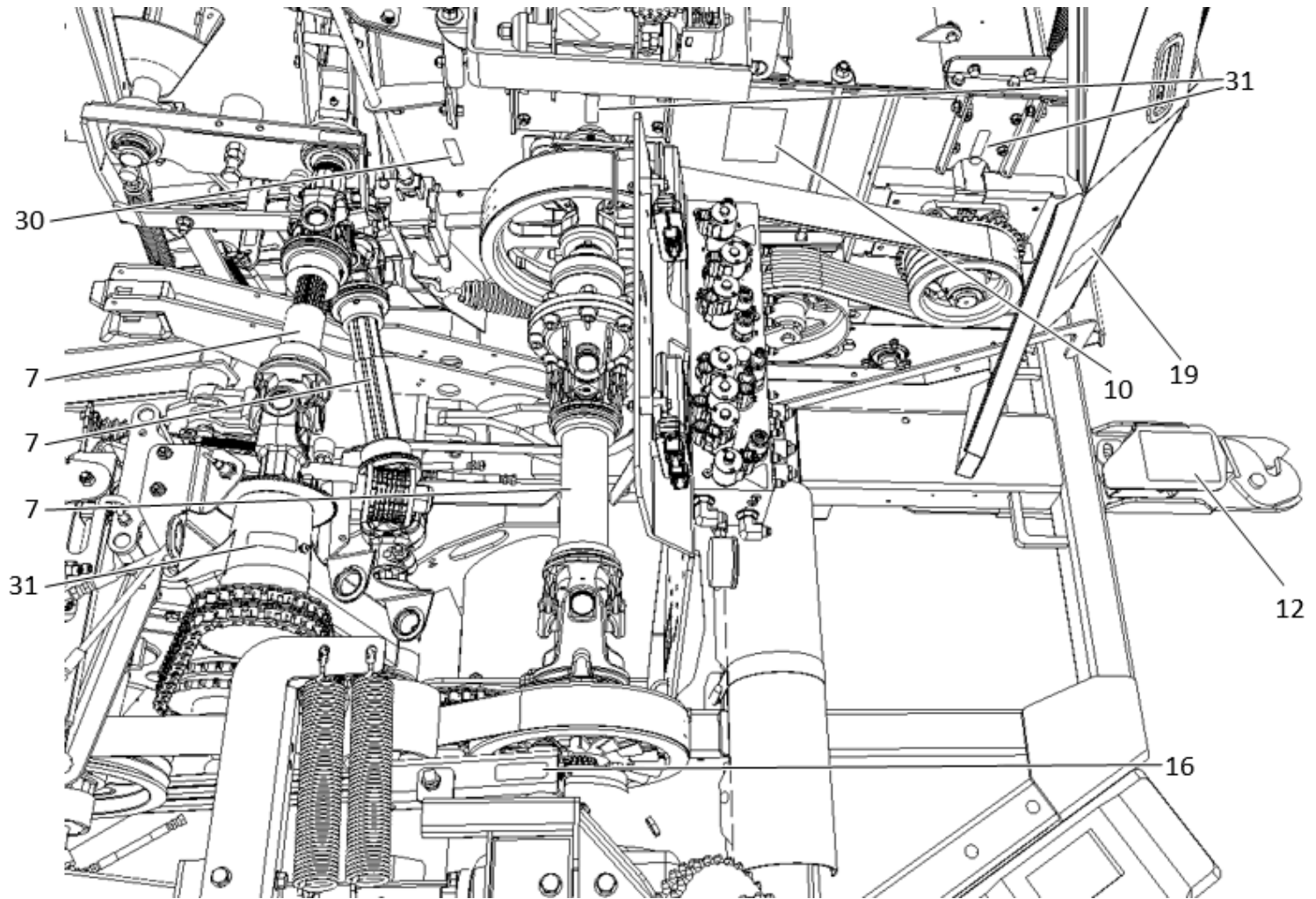

Figure 8 Safety Decals

SAFETY RULES

1 **DANGER**
TO AVOID SERIOUS INJURY OR DEATH, KEEP SHIELDS IN PLACE WHEN MACHINE IS RUNNING.
SHUT OFF ENGINE AND WAIT FOR ALL MOTION TO STOP BEFORE CLEANING OR SERVICING.
LES GARDES DE SÉCURITÉ DOIVENT ÊTRE LASSÉES EN PLACE POUR ÉVITER LES BLESSURES GRAVES OU MÊME LA MORT.
ARRÊTER LE MOTEUR DU TRACTEUR, DÉMARRER LA PRISE DE FORCE ET ATTENDRE QUE TOUT MOUVEMENT SOIT ARRÊTÉ AVANT D'AJUSTER OU DE NETTOYER.
FEL-02645F

2 **WARNING ATTENTION**
MAXIMUM SPEED LIMIT 25 mph
VITESSE MAXIMALE 40 km/h

3 **WARNING**
OPERATION
SET THE PTO TO CONTINUOUS MODE. LIMIT FLOW TO 3 GPM MAX AND ENSURE RETURN PRESSURE IS 300 PSI MAX TO PREVENT OVERHEATING.
TRANSPORT
NEVER DRIVING ON PUBLIC ROAD.
ALONG THE SPOUT AND SET IN TRANSPORT LOCK POSITION.
ALOCK THE HEADS CLINGER.
LOCK TOWBAR WITH SAFETY PIN.
TURN OFF THE HARVESTER CONTROL BOX.
SHUT OFF HYDRAULIC SUPPLY.
FAILURE TO SECURE THE SPOUT, HEADER AND TOWBAR FOR TRANSPORT CAN RESULT IN SEVERE INJURIES OR DEATH.
AVERTISSEMENT
OPERATION
ACTIVER LE JAUQUE D'ALIMENTATION EN MODE CONTINU. LIMITER LE DÉBIT À 3 L/MIN MAX ET LA PRESSION DE RETOUR À 300 PSI MAX POUR ÉVITER LA SURCHAUFFE.
TRANSPORT
NE PAS CONDUIRE SUR LA ROUTE.
PLACER LA CHAÎNE EN POSITION DE TRANSPORT VERROUILLÉE.
VERROUILLER LE CLINGEUR DE DÉBRAYAGE.
VERROUILLER LA BARRE À LA GOUPELLE DE SÉCURITÉ.
ÉTENDRE LA BOÎTE DE CONTRÔLE DE L'ENSLEUSE.
ARRÊTER L'ALIMENTATION HYDRAULIQUE.
OMETTRE DE SÉCURISER LA CROÛTE, LE TOUT DE SÉCURITÉ OU LA TIRE POUR LE TRANSPORT PEUT ENTRAINER DES BLESSURES GRAVES OU LA MORT.

4 **WARNING**
"CAUTION" TAG
"ATTENTION" TAG
IDENTIFICATION TAG
PLAQUE D'IDENTIFICATION
SAFETY CHAIN
CHAÎNE DE SÉCURITÉ
THE SAFETY CHAIN SHALL BE FASTENED TO THE ATTACHING POINTS OF TOWED AND TOWING MACHINES BY A POSITIVE MEANS WHICH CANNOT BE SEPARATED INADVERTENTLY.
THE SAFETY CHAIN SHALL HAVE NO MORE SLACK WHEN IN USE THAN NECESSARY TO PERMIT PROPER ARTICULATION OF MACHINES.
THE SAFETY CHAIN SHOULD HAVE A PERMANENT NON-CORRODING TYPE IDENTIFICATION TAG ATTACHED AS SHOWN ON DRAWING.
REPLACE THE SAFETY CHAIN IF ONE OR MORE LINKS ARE BROKEN, STRETCHED OR OTHERWISE DAMAGED OR DEFORMED.
ATTENTION
LA CHAÎNE DE SÉCURITÉ DOIT ÊTRE FIXÉE AUX POINTS D'ATTACHE DES MACHINES REMORQUÉES ET DE REMORQUAGE À L'AIDE D'UN DISPOSITIF SÛR QUI NE SE DÉTACHERA PAS ACCIDENTELLEMENT.
LA CHAÎNE DE SÉCURITÉ, LORSQU'UTILISÉE, NE DOIT PAS ÊTRE PLUS LÂCHE QUE NÉCESSAIRE MAIS JUSTE ASSEZ POUR QUE L'ARTICULATION DES MACHINES NE SOIT PAS ENTRAVÉE.
LA CHAÎNE DE SÉCURITÉ DOIT AVOIR UNE PLAQUE D'IDENTIFICATION PERMANENTE, ANTI-CORROSIVE ET ATTACHÉE TEL QU'ILLUSTRE SUR LE DESSIN.
LA CHAÎNE DE SÉCURITÉ DOIT ÊTRE REMPLACÉE SI UNE OU PLUSIEURS MAILLES SONT BRISÉES, ÉTIRÉES, DÉFORMÉES OU ENDOUMAGÉES D'UNE FAÇON QUELCONQUE.
18844

5 **1000 RPM**
[Icon of a gear with a circular arrow]

6 **WARNING**
[Diagram of a harvester with dimensions 'B' and 'A']
WHEN HITCHING THIS FORAGE HARVESTER TO YOUR TRACTOR, MAKE SURE THAT DISTANCE "A" OF PTO ROTATING GUARD IS GREATER THAN "ZERO" WITH TRACTOR AT ITS MAXIMUM TURNING ANGLE. TO INCREASE TURNING ANGLE, LENGTHEN TRACTOR DRAWBAR WITHIN THE RANGE OF MEASURE "B" OF 26" TO 34".
ATTENTION
LORSQUE VOUS ATTELEZ CETTE FOURRAGÈRE SUR VOTRE TRACTEUR, S'ASSURER QUE LA DISTANCE "A" DES GARDES ROTATIFS DE LA P.D.F. SOIT PLUS GRANDE QUE "ZÉRO" AVEC L'ANGLE DE BRAQUAGE DU TRACTEUR À SON MAXIMUM. POUR AUGMENTER L'ANGLE DE BRAQUAGE, ALLONGER LA BARRÉ DE TIRE DU TRACTEUR TOUT EN RESTANT DANS LA LIMITE "B" DE 26" À 34".
P-41-2076F

7 **DANGER**
SHIELD MISSING
DO NOT OPERATE
GARDE MANQUANT
NE PAS OPÉRER

8 **CAUTION**
Safety is of utmost importance when handling or applying farm chemicals. Before attempting to operate this equipment, read, study, and follow the chemical manufacturers recommendations. In addition, make sure that every individual who operates or works with this machine is familiar with the safety precautions listed in the operators manual.
AVERTISSEMENT
La sécurité est de toute importance lors de la manipulation ou de l'utilisation des produits chimiques agricoles. Avant de manipuler ou d'appliquer, lire, étudier et suivre les recommandations du fabricant du produit chimique. En plus, s'assurer que tout individu qui utilise ou travaille avec cette machine soit familiarisé avec les mesures de sécurité du manuel de l'opérateur.
2010306

9 **CAUTION**
FOR CORN ONLY
AVERTISSEMENT
POUR MAÏS SEULEMENT
20-0022F

10 **WARNING**
SHIELDS MISSING
DO NOT OPERATE
ALL GUARDS, SHIELDS AND DOORS SHOULD BE IN PLACE AND PROPERLY SECURED BEFORE STARTING THE TRACTOR ENGINE.
ATTENTION
PROTECTEURS MANQUANTS
NE PAS OPÉRER
V ASSURER QUE TOUTES LES GARDES, LES PROTECTEURS ET LES PORTES SOIENT BIEN EN PLACE ET DE FAÇON SÉCURITAIRE AVANT DE DÉMARRER LE MOTEUR DU TRACTEUR.
200-1720F

11 **DANGER**
• AVOID DEATH OR SERIOUS INJURY FROM ENTANGLEMENT IN THE FEED ROLLS. THE HARVESTER TAKES CROP FASTER THAN YOU CAN RELEASE IT.
• NEVER FEED THE FORAGE HARVESTER MANUALLY. NEVER OPERATE THE HARVESTER WITHOUT FIRST HAVING HITCHED A "DION" ATTACHMENT.
• IF A FEEDING OR THROWING MECHANISM BECOMES PLUGGED, NEVER ATTEMPT TO UNPLUG THEM WHEN THE MACHINE IS IN MOTION OR THE TRACTOR ENGINE RUNNING.
• NE RISQUEZ PAS DE BLESSURES SÉRIEUSES OU MÊME LA MORT EN TOUCHANT LES ROULEAUX D'ALIMENTATION. LA FOURRAGÈRE MANGE LE FOURRAGE PLUS RAPIDEMENT QUE VOUS POUVEZ LE LÂCHER.
• NE JAMAIS ALIMENTER LA FOURRAGÈRE AVEC LES MAINS OU LES PIEDS. NE JAMAIS UTILISER UNE FOURRAGÈRE SANS Y AVOIR PRÉALABLEMENT ADAPTÉ UN ATTACHEMENT.
• NE JAMAIS ESSAYER DE DÉBLOQUER OU D'ENLEVER DE L'ENLASE À LE TRACTEUR EST EN MARCHÉ.
2004

12 **DANGER**
TOUJOURS UTILISER UN PORT DÉDIÉ "R" OU "T" DU TRACTEUR POUR LE BOYAU "T" DE L'ENSLEUSE. TOUJOURS VERROUILLER AVEC LA GOUPELLE ET INSTALLER UNE CHAÎNE DE SÉCURITÉ POUR LE TRANSPORT SUR LA ROUTE. OMETTRE DE SUIVRE CES INDICATIONS PEUT CAUSER UN DÉCROCHAGE INATTENDU DE LA REMORQUE, DES BLESSURES GRAVES OU LA MORT.
ALWAYS USE TRACTOR DEDICATED "R" OR "T" PORT FOR THE HARVESTER "T" LINE. ALWAYS LOCK WITH THE PIN AND INSTALL A SAFETY CHAIN FOR ROAD TRANSPORT. FAILURE TO FOLLOW THESE GUIDELINES MAY RESULT IN UNEXPECTED TRAILER DISCONNECT, SEVERE INJURIES OR DEATH.
31777

13 **R N F**

14 Jaune-Yellow

16 Rouge-Red

17 Orange

Figure 9 Safety Decals

SAFETY RULES

15 —

LONGUEUR DE COUPE - (LOC) - LENGTH OF CUT

IMPORTANT
TOUJOURS GARDER LA CHAÎNE TENDUE. SERRER [C] À LA TENSION OPTIMALE ILLUSTRÉE. SE RÉFÉRER AU MANUEL DE L'OPÉRATEUR.

IMPORTANT
ALWAYS KEEP THE CHAIN TIGHTEN. TIGHTEN [C] TO REACH SHOWN OPTIMAL TENSION. REFER TO OPERATOR'S MANUAL.

LOC THÉORIQUE, po (mm) - THEORETICAL LOC, in (mm)

POULIE MENEUSE SUR TRANSMISSION DE COIN [B] - ANGLE DRIVE GEARBOX PULLEY [B]				POULIE MENEUSE SUR TRANSMISSION DE COIN [B] - ANGLE DRIVE GEARBOX PULLEY [B]			
LOC "L" (8.375" Ø)				LOC "H" (11.3" Ø)			
TEETH [A]	NUMBER OF CUTTERS - NUMBER OF KNIVES	TEETH [A]	NUMBER OF CUTTERS - NUMBER OF KNIVES	TEETH [A]	NUMBER OF CUTTERS - NUMBER OF KNIVES	TEETH [A]	NUMBER OF CUTTERS - NUMBER OF KNIVES
17	0.24 (6) 0.36 (9) 0.48 (12) 0.72 (18)	17	0.32 (8) 0.48 (12) 0.64 (16) 0.96 (24)	26	0.49 (12) 0.73 (19) 0.98 (25) 1.46 (37)	34	0.64 (16) 0.96 (24) 1.28 (32) 1.92 (48)

18 —

20 —

⚠ DANGER

TO AVOID INJURY OR DEATH DO NOT CONTACT ELECTRIC LINES

ÉVITER LE CONTACT AVEC LES LIGNES ÉLECTRIQUES. NE RISQUEZ PAS DES BLESSURES OU MÊME LA MORT.

F41-22269

19 —

⚠ DANGER

ALWAYS LOCK THE LIFT CYLINDER WHILE IN TRANSPORT. LOCK AND INSTALL A SAFETY JACK STAND BEFORE ACCESSING UNDER THE HEADER.

TOUJOURS VERROUILLER LE CYLINDRE DE RELEVAGE EN TRANSPORT. VERROUILLER ET INSTALLER UNE CHANDELLE DE SÉCURITÉ AVANT D'ACCÉDER AU-DESSOUS DE L'OUTIL.

32 —

WARNING ⚠ AVERTISSEMENT

- Set the PTO at idle RPM.
- Fully loosen the rock and pinion (A).
- Unlock the shifter adjustment bolt (B).
- Tighten the adjusting screw slowly (C) to reduce the distance between the bar and the knives.
- Tighten (C) until a light audible ruck then back up slightly until the ruck disappears.
- Tighten the rock and pinion (A) slowly and carefully **WARNING:** There should be no contact or knocking when tightening the rock and pinion (A). Slowly loosen (A), back up (C) slightly more and tighten back (A).
- Lock the shifter adjustment bolt (B).

- Ajuster le RPM de la POF au ralenti.
- Déserrer **COMPLÈTEMENT** la crémaillère (A).
- Débloquer le bouton d'ajustement de la barre de coupe (B).
- Serrer lentement le vis d'ajustement (C) pour réduire le dégagement entre la barre et les couteaux.
- Serrer (C) jusqu'à ce qu'un léger cognement soit entendu puis rendre jusqu'à la disparition du cognement.
- Déserrer la crémaillère (A) lentement et avec précaution. **ATTENTION:** Il ne devrait y avoir ni contact ni son en resserrant la crémaillère (A). Ajustement, desserrer (A) et reculer (C) légèrement puis resserrer (A).
- Bloquer le bouton d'ajustement de la barre de coupe (B).

21 —

PUSH TO UNLOCK
APPUIEZ POUR DÉVERROUILLER

22 —

⚠ ATTENTION

AVANT D'OPÉRER CET ÉQUIPEMENT, LIRE ET ÉTUDIER LES RÈGLES DE SÉCURITÉ SUIVANTES. DE PLUS, S'ASSURER QUE TOUTE PERSONNE OPÉRANT OU TRAVAILANT AVEC CET ÉQUIPEMENT CONNAÎT BIEN CES RÈGLES DE SÉCURITÉ.

- ENLEVER LA P.D.F. TÉLÉSCOPIQUE DE L'ARBRE DE LA P.O.F. DU TRACTEUR AVANT D'AJUSTER DES PIÈCES SUR LA FOURRAGÈRE.
- BLOQUER LES ROUES DE LA FOURRAGÈRE DE FAÇON À CE QUE LA MACHINE NE BLOQUE PAS LORSQUE L'EST DÉTÊLÉ DU TRACTEUR.
- NE PAS FAIRE FONCTIONNER LA MACHINE AVANT QUE TOUTS LES GARDÉS ET PROTECTEURS DE SÉCURITÉ SOIENT FIXÉS EN PLACE.
- NE PAS SE TENIR EN-DESSOUS DE LA COURRIÈRE LORSQUE LA MACHINE EST EN OPÉRATION.
- NE PAS ALIMENTER CETTE MACHINE MANUELLEMENT AVEC OÙLEQUE FOURRAGE QUE CE SOIT.
- NE PAS PORTER DE VÊTEMENTS AMPLES OU BOUFFANTS POUR OPÉRER CETTE MACHINE.

23 —

⚠ WARNING

BEFORE YOU ATTEMPT TO OPERATE THIS EQUIPMENT, READ AND STUDY THE FOLLOWING SAFETY INFORMATION. IN ADDITION MAKE SURE THAT EVERY INDIVIDUAL WHO OPERATES OR WORKS WITH THIS EQUIPMENT IS FAMILIAR WITH THESE SAFETY PRECAUTIONS.

- REMOVE TELESCOPING DRIVE FROM TRACTOR P.T.O. SHAFT BEFORE ADJUSTING PARTS ON THE HARVESTER.
- BLOCK HARVESTER WHEELS SO IT WILL NOT ROLL WHEN DISCONNECTED FROM TRACTOR.
- DO NOT START THE MACHINE UNTIL ALL GUARDS AND SAFETY SHIELDS ARE SECURED IN PLACE.
- DO NOT STAND UNDER THE DISCHARGE DEFLECTOR WHEN THE MACHINE IS RUNNING.
- DO NOT ATTEMPT TO HAND FEED ANY CROP OR MATERIAL INTO THIS MACHINE.
- DO NOT WEAR LOOSE OR BAGGY CLOTHES WHEN OPERATING THE MACHINE.

24 —

25 —

⚠ WARNING
DO NOT OPEN WHILE MACHINE IS IN OPERATION

⚠ ATTENTION
ARRÊTER LE MÉCANISME AVANT D'OUVRIR

S45-17435

26 —

NOTICE FROM MANUFACTURER SPECIAL GREASE FOR HIGH SPEED BEARINGS

AFTER EVERY 40 HOURS OF WORK AND AT THE END OF THE SEASON LUBRICATE THE HIGH SPEED BEARINGS (IDENTIFIED BY THE GREEN AND WHITE SYMBOL) WITH 2 PUMP STROKES OF GREASE PART NUMBER F41-22269P. FAILURE TO DO SO WILL VOID WARRANTY ON KERNEL PROCESSOR BEARINGS AND ROLLS.

AVIS DU MANUFACTURIER GRAISSE SPÉCIALE POUR ROULEMENTS HAUTES VITESSES

À TOUTS LES 40 HEURES DE TRAVAIL ET À LA FIN DE LA SAISON, GRAISSEZ LES ROULEMENTS HAUTES VITESSES (IDENTIFIÉS PAR UN FUSIL GRAISSEUR VERT ET BLANC) AVEC 2 COUPS DE POMPE DE GRAISSE NUMÉRO F41-22269P. TOUT MANQUEMENT À CET AVIS ANNULERA LA GARANTIE DES ROULEMENTS ET DES ROULEAUX CRAQUEURS.

27 —

⚠ WARNING

ROTATING PARTS INSIDE THIS OPENING. SHUT OFF TRACTOR ENGINE AND DISENGAGE POWER TAKE OFF AND WAIT FOR ALL MOTIONS TO STOP BEFORE CLEANING OR SERVICING.

⚠ ATTENTION

IL Y A DES PIÈCES ROTATIVES À L'INTÉRIEUR DE CETTE OUVERTURE. ARRÊTER LE MOTEUR DU TRACTEUR ET DÉSENGAGER LA PRISE DE FORCE. ATTENDRE QUE TOUT MOUVEMENT SOIT ARRÊTÉ AVANT D'AJUSTER OU DE NETTOYER.

S45-17871

28 —

⚠ DANGER

BEFORE OPENING THE CUTTER HEAD COVER, DISENGAGE THE TRACTOR P.T.O. STOP THE TRACTOR ENGINE AND MAKE SURE ALL MOVEMENTS HAVE STOPPED. REMOVE THE TELESCOPING DRIVE FROM THE TRACTOR.

AVANT D'OUVRIR LA TÊTE DE COUPE, DÉSENGAGER LA P.D.F. DU TRACTEUR. ARRÊTER LE MOTEUR DU TRACTEUR ET S'ASSURER QUE TOUT MOUVEMENT SOIT ARRÊTÉ. ENLEVER LA P.D.F. TÉLÉSCOPIQUE DE L'ARBRE DE LA P.D.F. DU TRACTEUR.

T29-17988P

29 —

⚠ DANGER

KNIFE SHARPENING
ALWAYS REFER TO THE OPERATOR'S MANUAL INSTRUCTIONS

AIGUISAGE DES COUPEAUX
TOUJOURS SE RÉFÉRER AUX INSTRUCTIONS DU MANUEL D'OPÉRATEUR

T29-17984P

30 —

40h

31554

31 —

10h

31552

Figure 10 Safety Decals

SETUP

BOLT TORQUE SPECIFICATIONS

The table below gives the correct torque values for bolts used on the machine. Check tightness of bolts periodically.

BOLT DIAMETER	SAE-2		SAE-5		SAE-8	
	ft-lb	Nm	ft-lb	Nm	ft-lb	Nm
1/4"	6	8	9	12	12	16
5/16"	10	13	19	25	25	34
3/8"	20	27	33	45	50	68
1/2"	45	61	80	110	125	170
5/8"	95	128	160	215	245	332
3/4"	170	230	280	380	425	577

BOLT DIAMETER	10.9	
	ft-lb	Nm
M6	13	17
M8	32	44
M10	63	85
M12	111	150
M14	177	240
M16	280	380

Table 1 Bolt torque specifications

NOTE: Replace hardware with the same grade bolt.

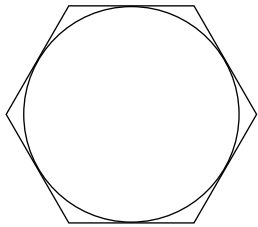

SAE 2

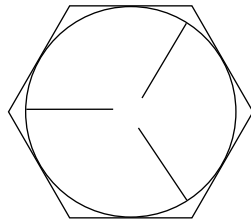

SAE 5

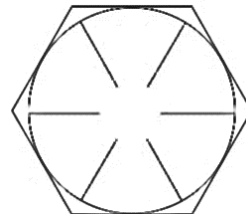

SAE 8

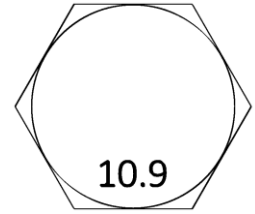

10.9

Figure 11 Bolt grades

SETUP

MANUAL JACK

FIGURE 12

The harvester is delivered with a manual jack (item 1) to support the drawbar when stored. When this jack is not used, it can be stored in its horizontal position using the locking pin (item 2).



CAUTION: Securely block the forage harvester wheels before removing the tractor hitch pin.

CAUTION: Make sure the lock pin (item 2) securing the jack in its horizontal or vertical position is properly engaged through the tubes.

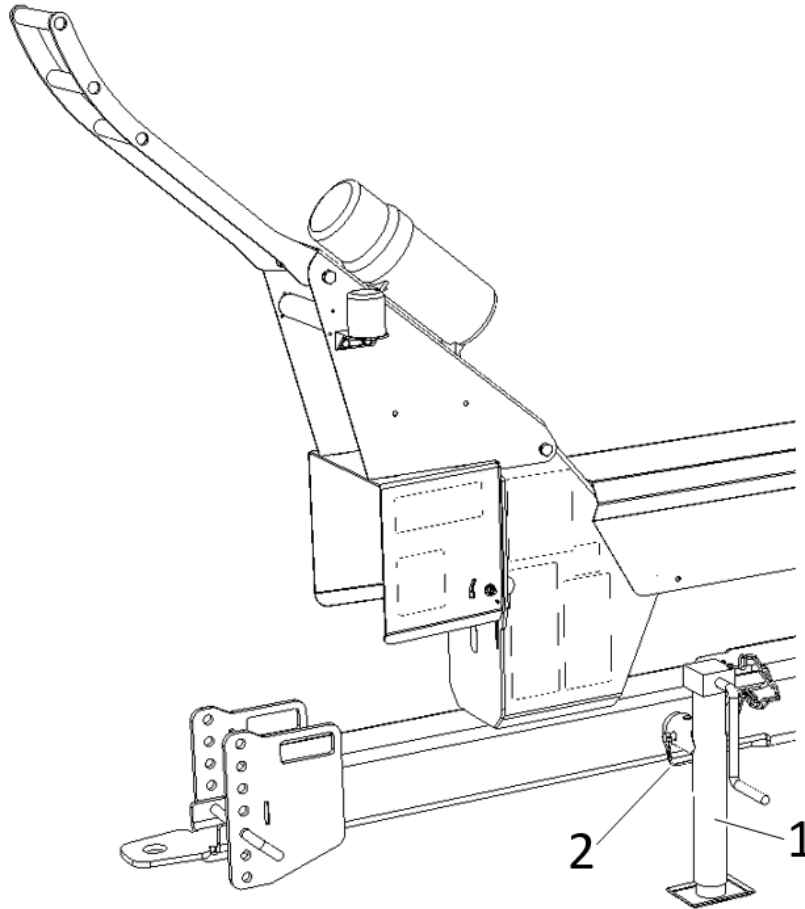

Figure 12 Manual jack

12V POWER CONNECTION

NOTE: The metal detector may require operation current of up to 25 Amps, for short periods. The control box may be connected directly within the cab to a standard AMP, 3pin, 12V plug, provided it offers circuit protection of at least 25A. If no appropriate plug is available, use the optional battery connection cable (Through Parts Department). In this case:

1. Disconnect the battery ground (-) connection to the frame.
2. Connect the black wire to the tractor frame or matching negative (-) battery terminal.
3. Connect the white wire to the positive stud (+).
4. Reconnect the negative (-) battery stud to the frame.
5. Ensure all connections are properly tightened and protected.
6. Make sure the power cable is well fastened and routed away from moving parts.

SETUP

CONTROL BOX INSTALLATION

FIGURE 13

1. Install the control box mounting knob in the cab in an accessible location from the seat. The mount is provided with the control box. Install the control box on the mounting arm (item 2).
2. Connect the control box to a 12V power outlet in the cab or to the optional battery cable.
3. Connect the control box to the harvester with the quick connectors (item 4).

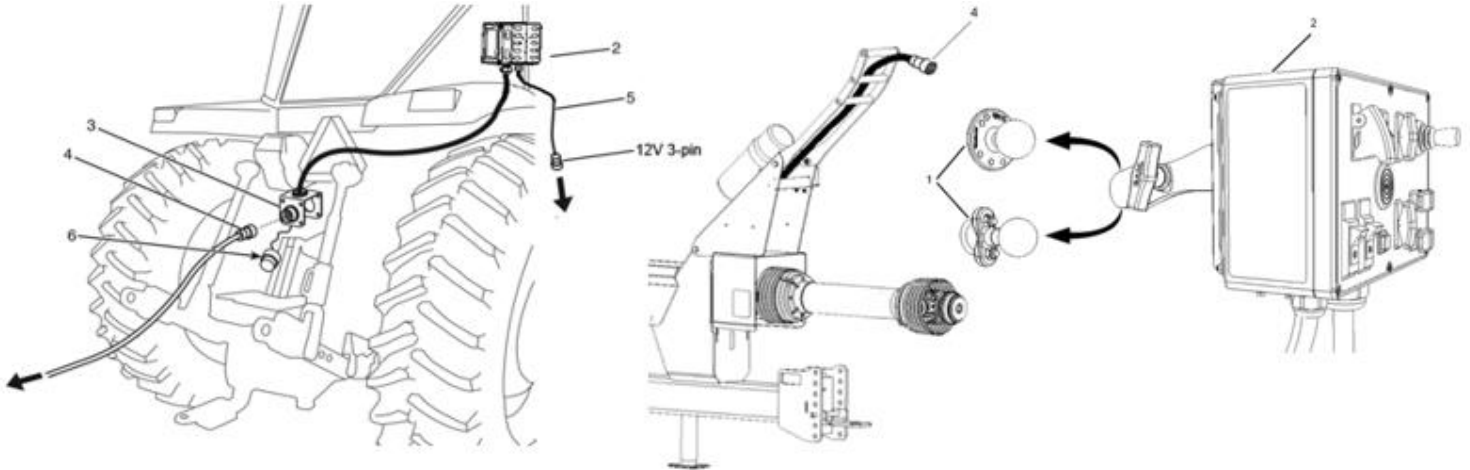

Figure 13 Control box Installation

HYDRAULIC CONNECTION

The Scorpion 300 harvester requires a continuous adjustable hydraulic flow from the tractor to operate correctly. Only two lines are required, 'P' (flow/pressure) and 'T' (Tank/Return). A reverse connection is prevented by a check valve in the harvester hydraulic valve manifold. Ideally, connect the tank line (T) to a motor return port on the tractor (often used for hydraulic motor return on planters or sprayers), that offer a low flow resistance. Do NOT use a case drain port, since these are not filtered and designed for very low flow. If no return port is available, contact your local tractor service provider to install one. Figure 14 shows a typical example of proper hydraulic connection.

1. Connect « P » hose to a tractor SCV with adjustable flow.
2. Connect « T » preferably to a free return port (motor return), often identified « T » or « R » on the tractor.
3. Adjust the valve flow to **less than 3gpm (10l/min)**.
4. Activate the valve in continuous flow mode before turning on the control box or the tractor PTO.

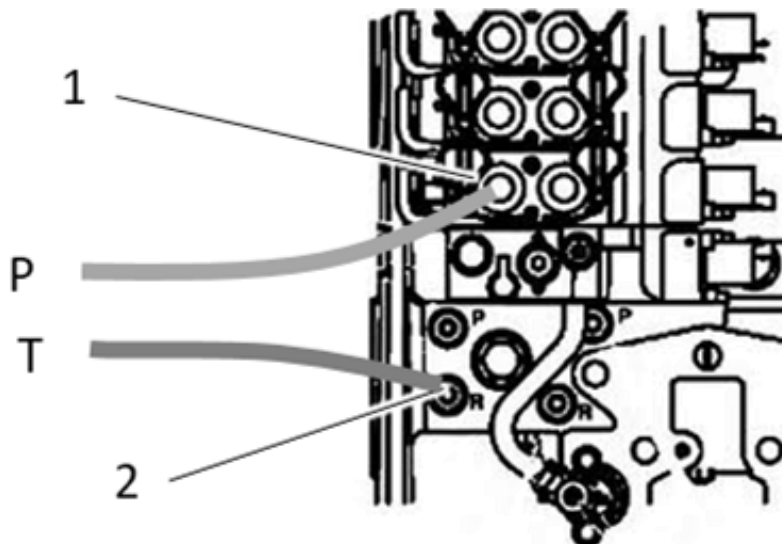

Figure 14: Hydraulic connection

SETUP



WARNING: Check the return pressure indicated on the pressure gauge located on the harvester valve manifold. A **maximum pressure of 50 psi** is required. A higher pressure can cause hydraulic system malfunctions.

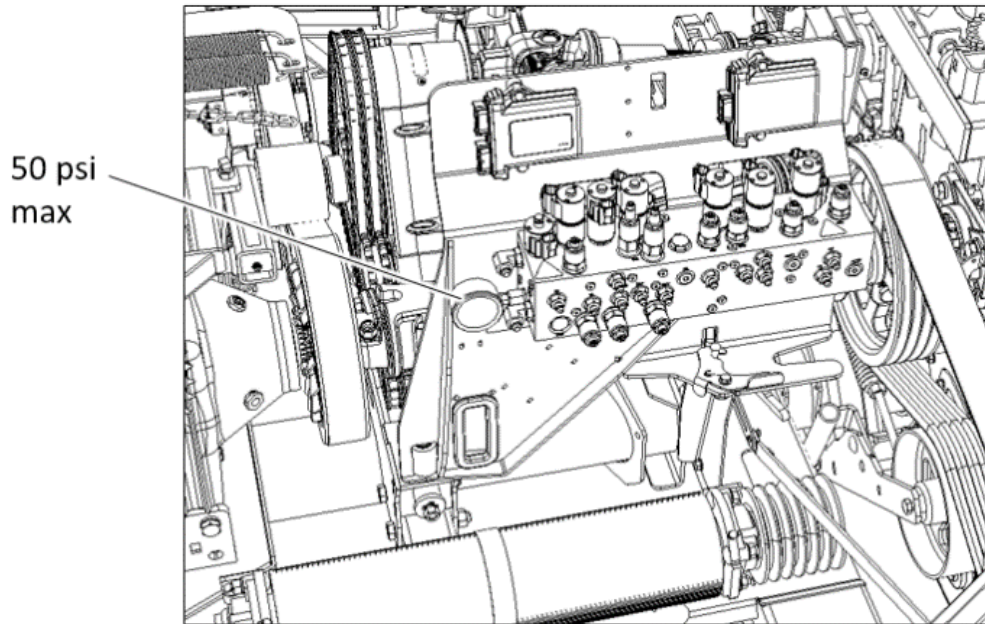

Figure 15: Pressure gauge

The return pressure is affected by two factors:

- **« T » connection:** Connecting the « T » line to the tractor SCV may create too much restriction. Use a free return port.
- **Flow:** Make sure flow is reduced below 3gpm. Higher flow increases resistance and can create over heating problems.

CONNECTING THE HARVESTER TO THE TRACTOR

FIGURE 17

The tractor drawbar (item 1) must be centered and aligned with the PTO driveshaft (item 2) (do not use offset drawbar). Align the harvester shaft (item 3) parallel with the tractor PTO (item 5) by adjusting the height of the adjustable drawbar (item 4).

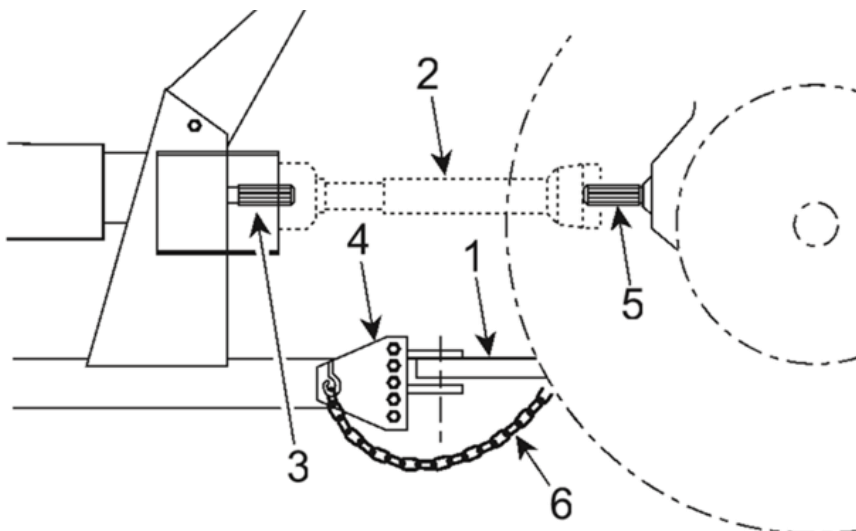

Figure 16 PTO shaft alignment

SETUP

FIGURE 17

Ensure the distance "A" (remaining stroke) of the driveshaft guard is greater than zero when the tractor is at its maximum turning angle. To increase the turning angle and eliminate vibration, position the tractor drawbar to a length "B" between 50 cm (20") and 60 cm (24"). If the drawbar can't achieve this setting, purchase a drawbar extension available at your DION-Ag Inc. dealer.

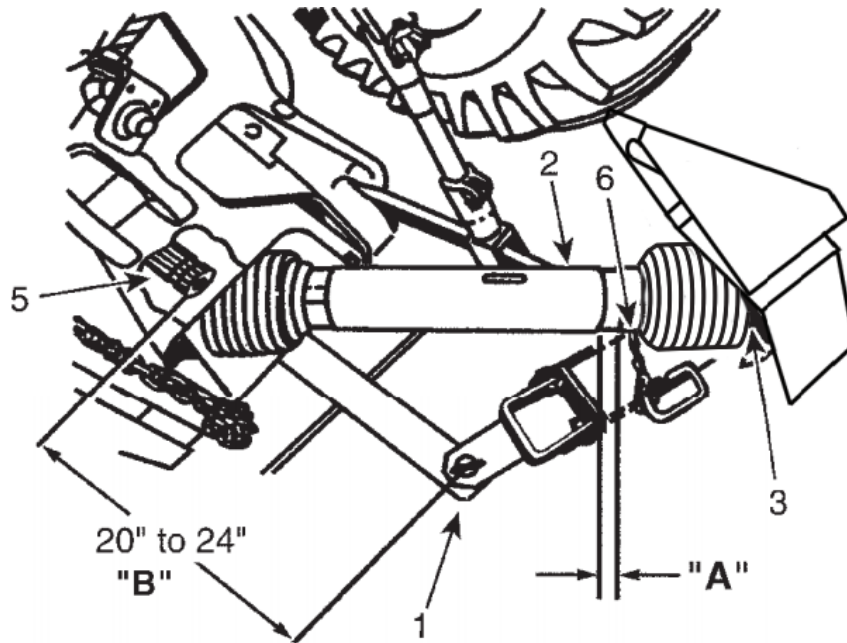

Figure 17 Tractor drawbar length adjustment



CAUTION: To prevent the rotation of the PTO shields, fastening chains (item 6, FIGURE 17) are provided and must be attached on both ends.



CAUTION: Attach a safety chain (item 7, FIGURE 18) with a minimum capacity of 9071 kg (20 000 lbs) for transport.

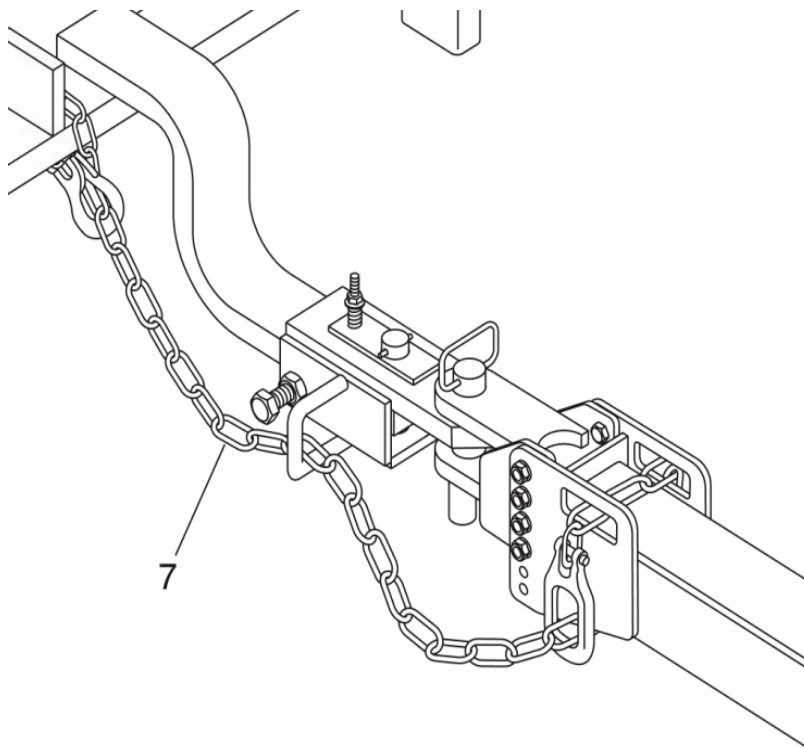

Figure 18 : Safety chain

SETUP

DRAW BAR EXTENSION

In the case where the tractor drawbar is too short, proceed to install the drawbar extension.

FOLLOW THESE INSTRUCTIONS TO INSTALL A **CAT. II** DRAW BAR EXTENSION

Refer to FIGURE 19 for the installation steps:

1. Determine if the hole in the draw bar (item 4) is too large for use with pin (item 9). If yes, use bushing (item 13) in the hole to reduce the clearance with pin (item 9). Set the parts you need aside until Step 4.
2. Insert shims (items 1 and 2) inside the extension (item 3). Insert extension (with shims) onto the draw bar (item 4).
3. Insert bolt (item 6) through the extension from underneath (Figure 19 Cat. II drawbar extension). Place plate (item 5) onto bolt (Item 6). Install the spring (item 7) and nut (item 8) on bolt (item 6). Do not overtighten. Leave enough play to allow retention or removal of lock pin (item 9).
4. Using pieces determined in Step 1, install pin (item 9) with spring pin (item 10) into extension (item 3) and lock it in place with plate (item 5).
5. Install nuts (item 12) onto bolts (item 11) and then install bolts (item 11) into both sides of the extension (item 3) as shown below.
6. Center the extension (item 3) on the draw bar (item 4). To center side to side, use the bolts (item 11). Once centered, lock the bolts in place using the nuts (item 12).
7. Insert pin (item 14) and lock with the safety pin (item 15).

NOTE: items 14 and 15 are not supplied by the manufacturer

8. Install the safety chain (item 16) between the tractor frame and the Forage Harvester. Refer to Figure 18 : Safety chain on page Figure 18 : *Safety chain* for more information on how to install the safety chain.

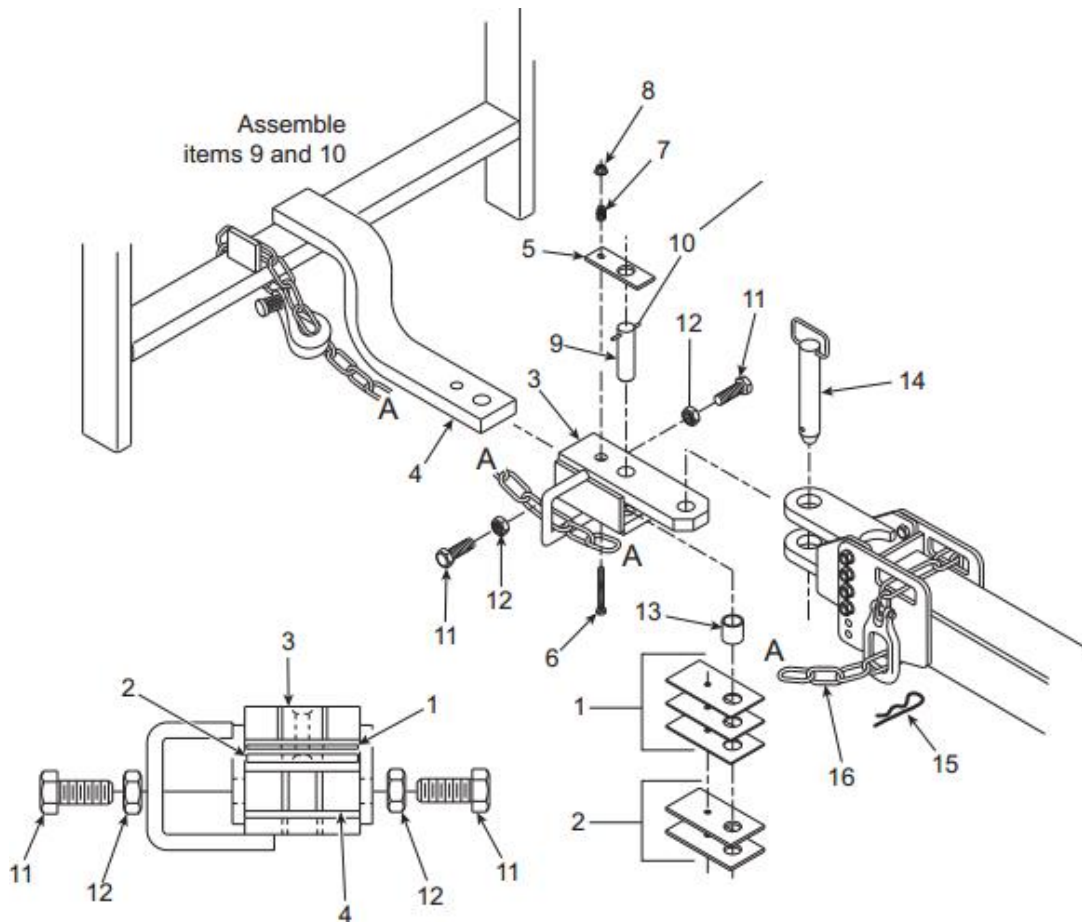

Figure 19 Cat. II drawbar extension

SETUP

FOLLOW THESE INSTRUCTIONS TO INSTALL A **CAT. III AND CAT. IV** DRAW BAR EXTENSION:

Refer to Figure 20 for the installation steps:

1. Determine if the hole in the draw bar (item 4) is too large for use with pin (item 9). If yes, use bushing (item 13) in the hole to reduce the clearance with pin (item 9). Set the parts you need aside until Step 4.
2. Insert shims (items 1 and 2) inside extension (item 3). Insert extension with shim onto the draw bar (item 4).
3. Insert two stove bolts (item 6) through the required shims as shown below. Insert bolts (item 6) inside the extension (item 3) and screw the nuts (item 8) on the stove bolts (item 6). Adjust the shims to eliminate play between the extension and the tractor's drawbar. Tighten the nuts (item 8).
4. Using pieces determined in Step 1, install pin (item 9) through extension (item 3) and lock it in place with spring pin (item 10).
5. Install nuts (item 12) on bolts (item 11) and then install bolts (item 11) on both sides of extension (item 3) as shown below.
6. Center the extension (item 3) on the draw bar (item 4). To center side to side, use the bolts (item 11). Once centered, lock the bolts in place using the nuts (item 12).
7. Insert pin (item 14) and lock with the safety pin (item 15).

NOTE: items 14 and 15 are not supplied by the manufacturer

8. Install the safety chain (item 16) between the tractor frame and the Forage Harvester. Refer to Figure 18 : Safety chain on page Figure 18 : *Safety chain* for more information on how to install the safety chain.

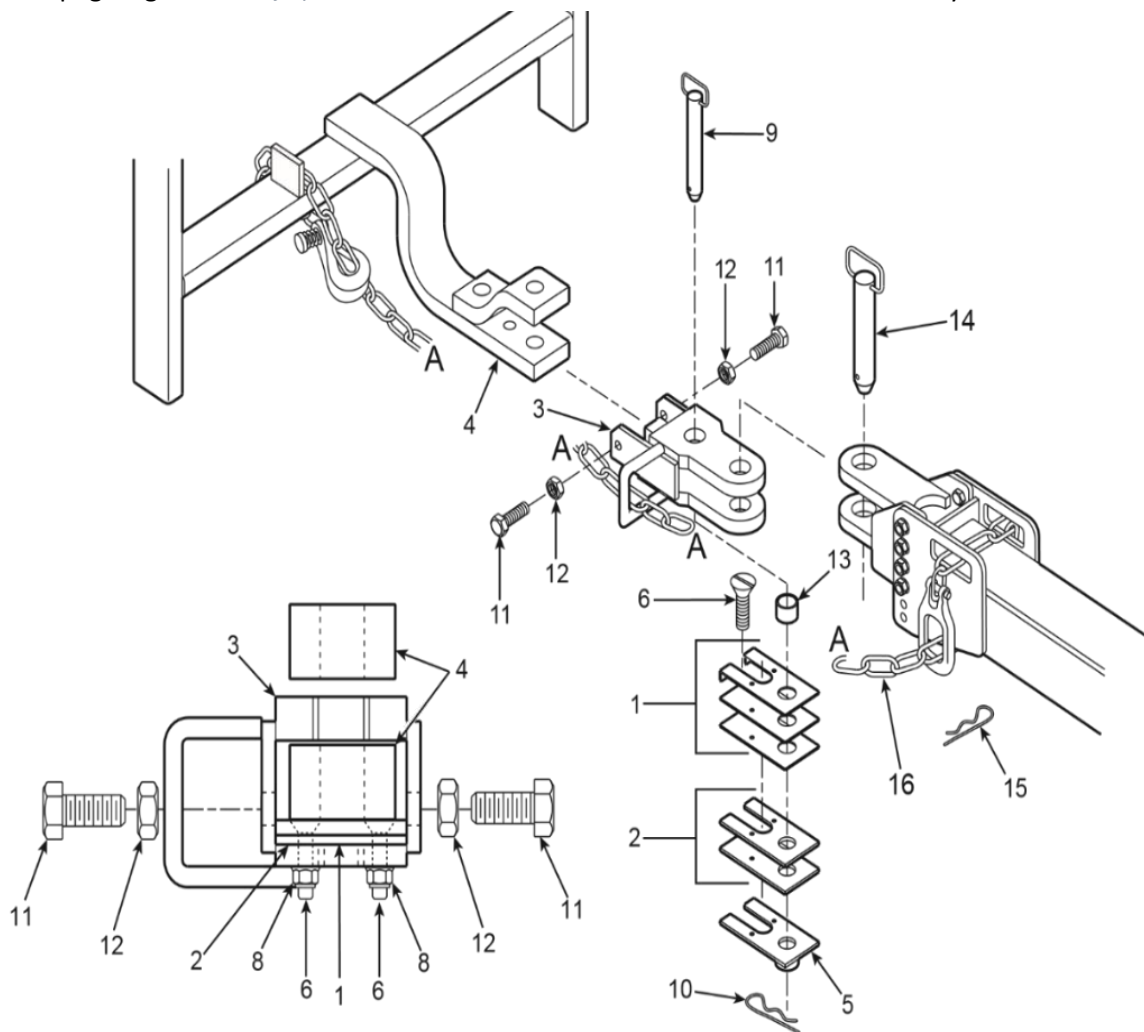

Figure 20 Cat. III and IV drawbar extension

SETUP

CONFIGURING FOR CORN HARVEST SETUP

To harvest corn, the PROCESSOR top roll must be re-installed. Follow the instructions below:

STEP 1 - FIGURE 21

Open the main guard. Pull the release lever and swing the hydraulic valve manifold to free space around the accelerator belt tensioner.

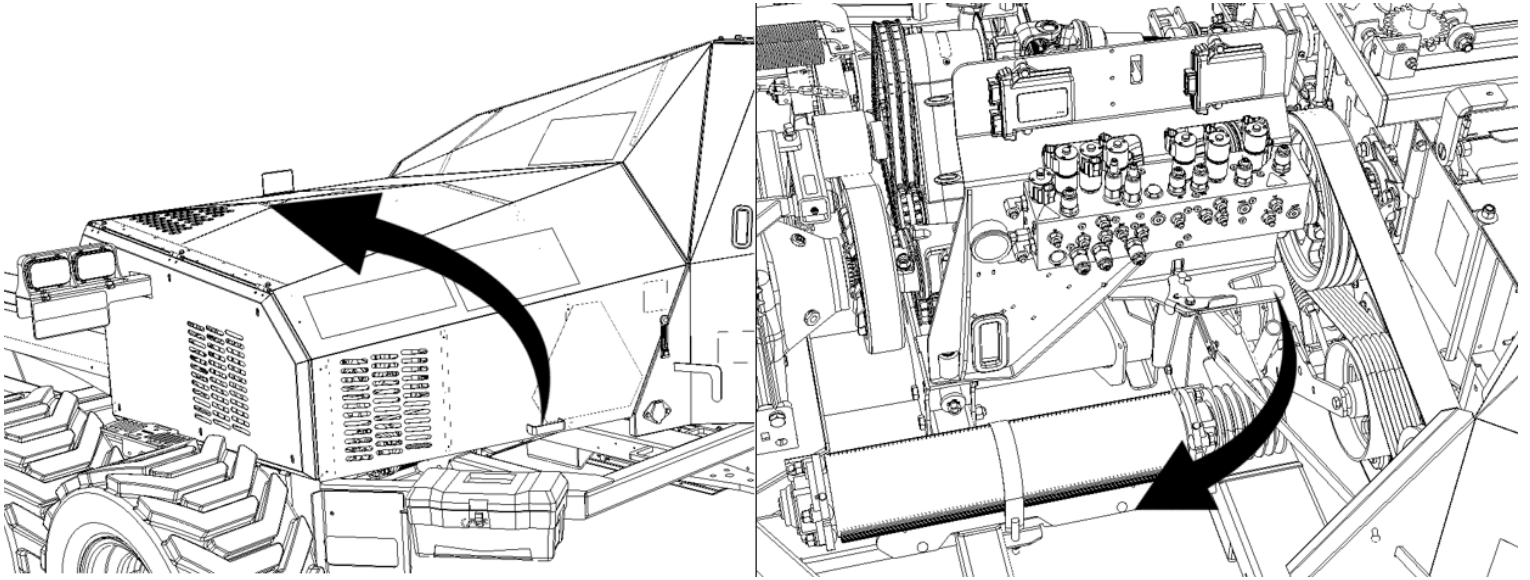

Figure 21 Main guard and valve manifold

STEP 2 - FIGURE 22

Remove the lock pin (item 1) and the header lift cylinder locking arm (item 2). Remove the bolt and nut that locks the accelerator tensioner (item 3 and 4). Store these parts temporarily in a safe place.

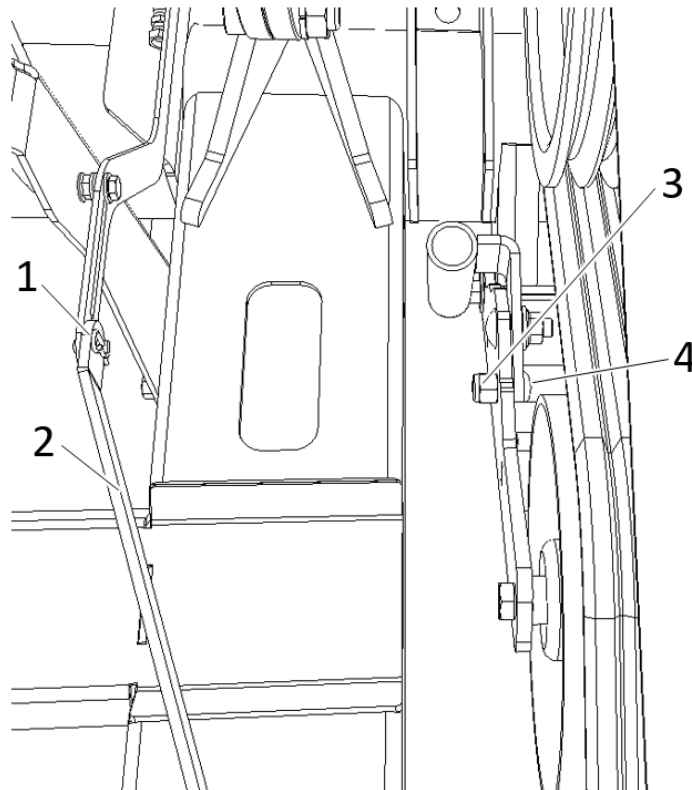

Figure 22 Cylinder lever arm and lock bolt

SETUP

STEP 3 - FIGURE 23

Use the knife guide bar stored on the machine (item 1) to unlatch the accelerator tensioner. Unhook the spring (item 2) from the front bracket to completely lower the tensioner assembly. Remove the belt to access the roller opening in the frame.

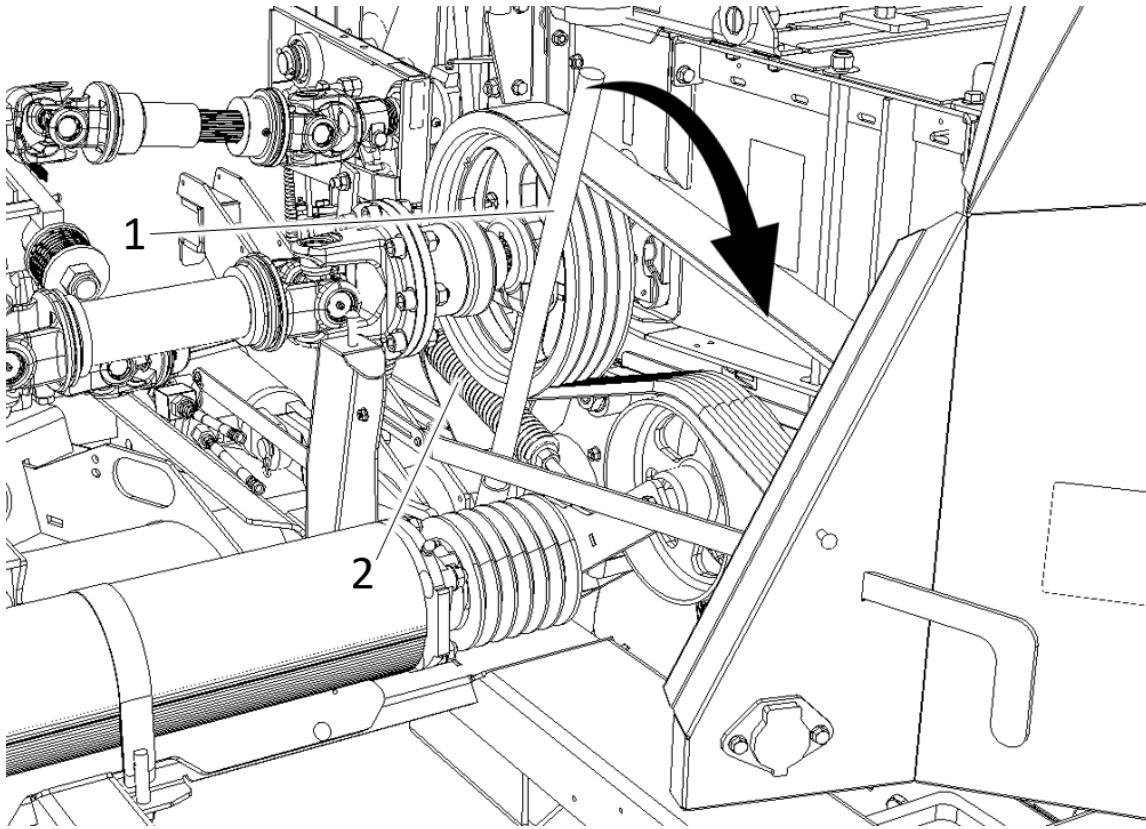

Figure 23 Accelerator tensioner



CAUTION: Work safely when you work or operate the harvester.

STEP 4 - FIGURE 24

Loosen the two left cover plate bolts (item 1) and similarly on the right-hand side (item 2). Remove the cover plates and store them in the machine toolbox.

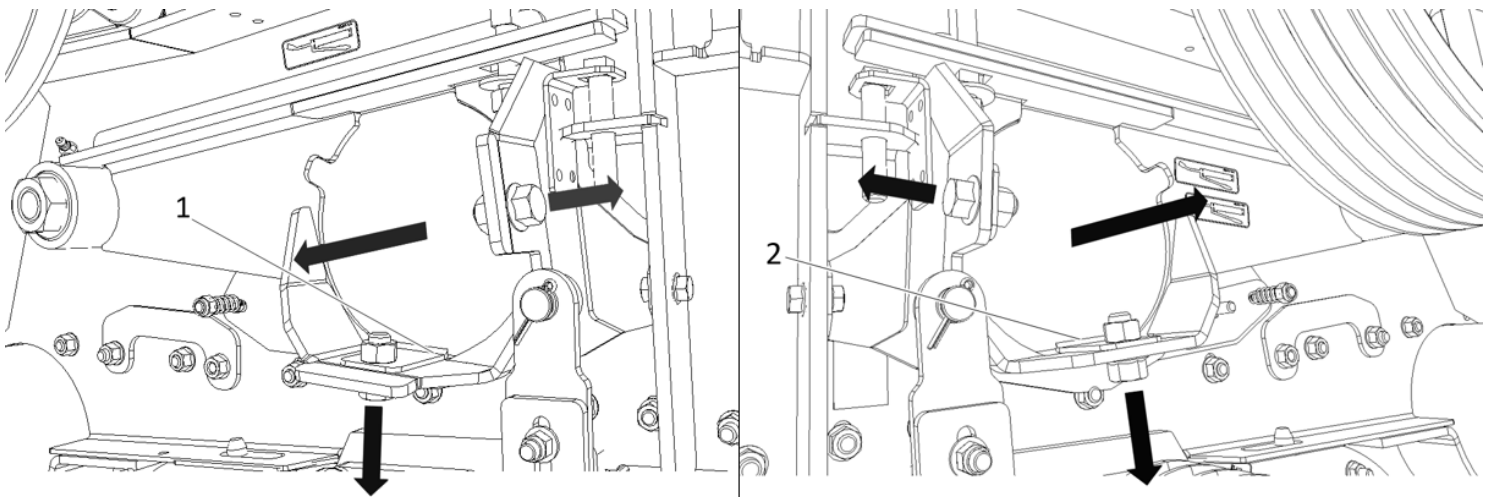

Figure 24 Cover plates

SETUP

STEP 5 - FIGURE 25

Support the processor roll unit and loosen the processor roll fastening bolts at the rear (left and right) (item 1). Lower the processor roll unit carefully to gain access to the roller assembly. Remove the stainless cover plate (item 2) on the bottom roll (item 3) as shown and store the pieces. Carefully clean all contact areas and proceed to lift the bottom frame back up while ensuring no parts are being pinched. Tightened all the bolts (item 1) back to the required torque (See Table 1, page 22).

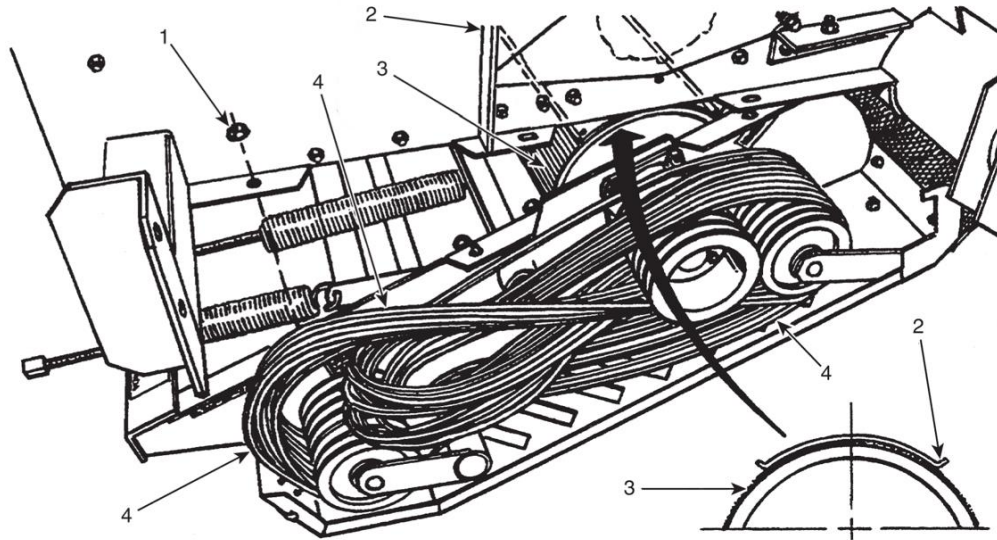

Figure 25 Processor roll unit

STEP 6 - FIGURE 26

Remove the strap from the top roll (item 1) and its rubber cover (item 2), and store them in the toolbox. Slide the roller in the frame openings and roller stabilization arms (item 3).



CAUTION: HEAVY part. Lift carefully and be careful not to pinch fingers during installation.

NOTE: Thoroughly clean the pans inside the crop channel to remove residue before installing the top roller.

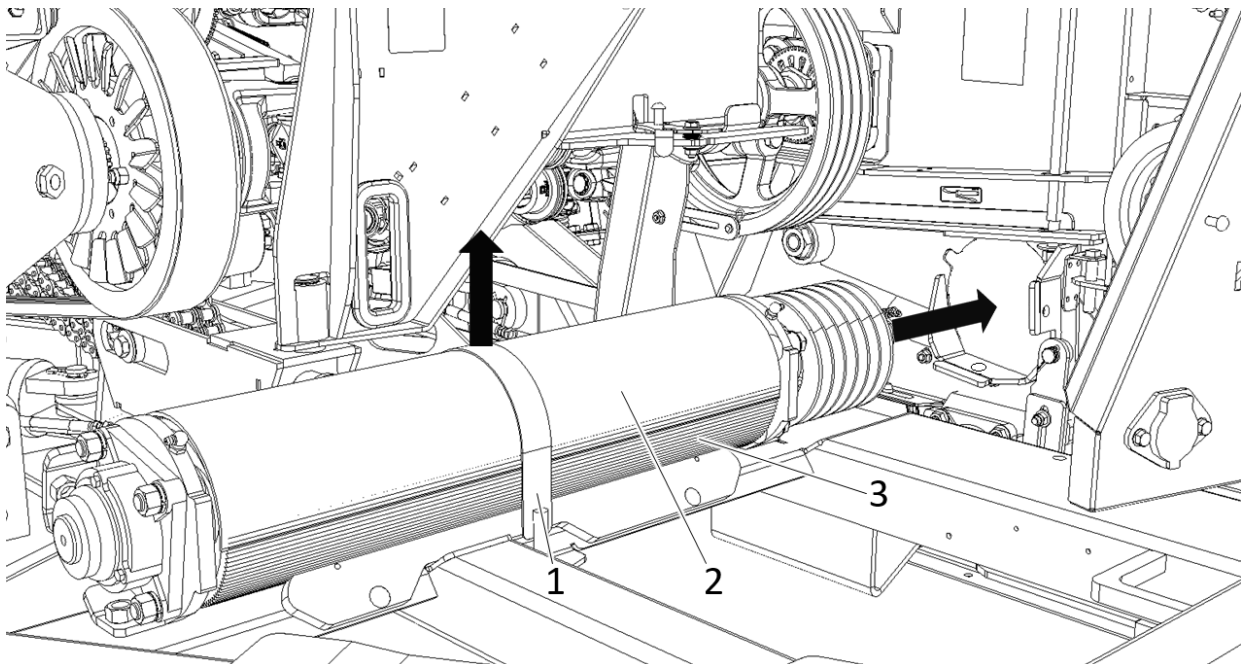

Figure 26 Strap, cover and top processor roll

SETUP

STEP 7 - FIGURE 27

Install the processor bearing plates on both sides (items 1 & 2). Each bearing plate must be fastened with using: 2ea - 1/2" dia. X 1" long flange bolts.

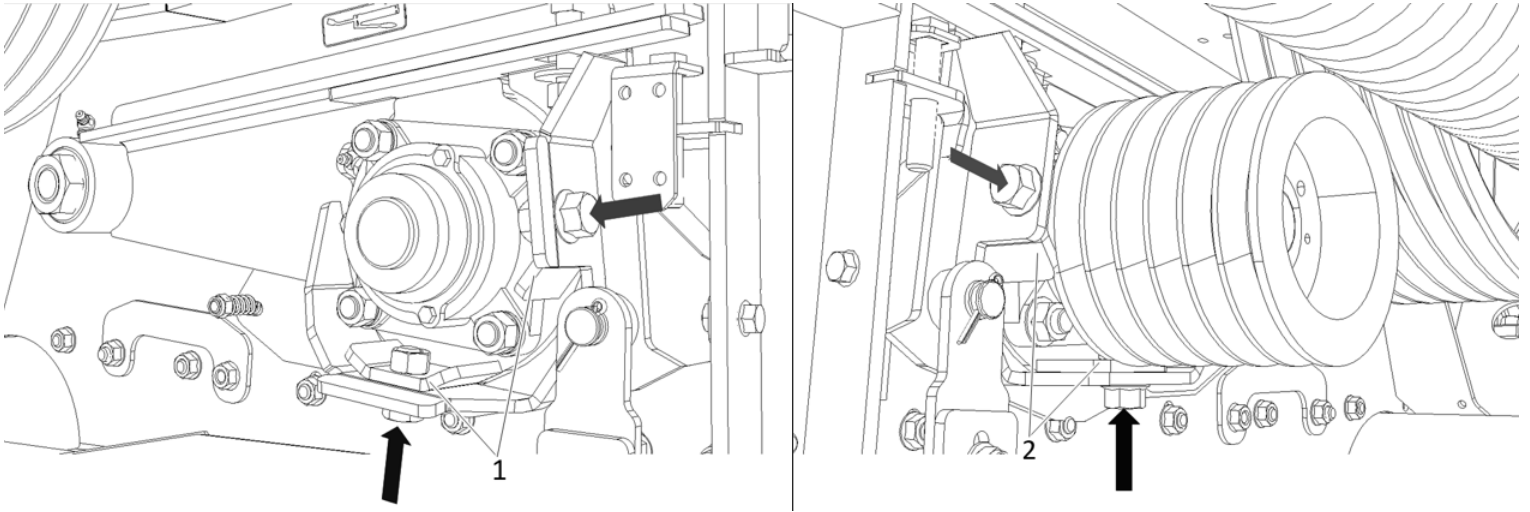

Figure 27 Bearing supports

STEP 8 - FIGURE 28

Ensure the tension on the pulley tensioning spring (item 3) is released by unscrewing the right-hand rod at the rear of the harvester (item 2) using the provided square head tool (item 4).



CAUTION: Rotate the pulley carefully and be careful not to pinch fingers during installation.

The drive pulley (item 2) has 6 slots for 6 belts. If you consider the pulley slot closest to the machine body #6 and furthest from the machine body #1, install the **six** belts (item 1), one belt at a time, in the following order:

NOTE: Ensure the belts are not twisted and the pulleys and belts are properly cleaned and free of grease and oil.

Start on the drive pulley side between the drive pulley and the machine body always rotating counter clockwise as shown in Figure 28 Belt Installation. First install belt #4, #5 and end with #6 (item 3).

For the remaining 3 belts, continue to rotate the drive pulley counter clockwise. Install the belts #3, #2 and end with #1 (item 4).

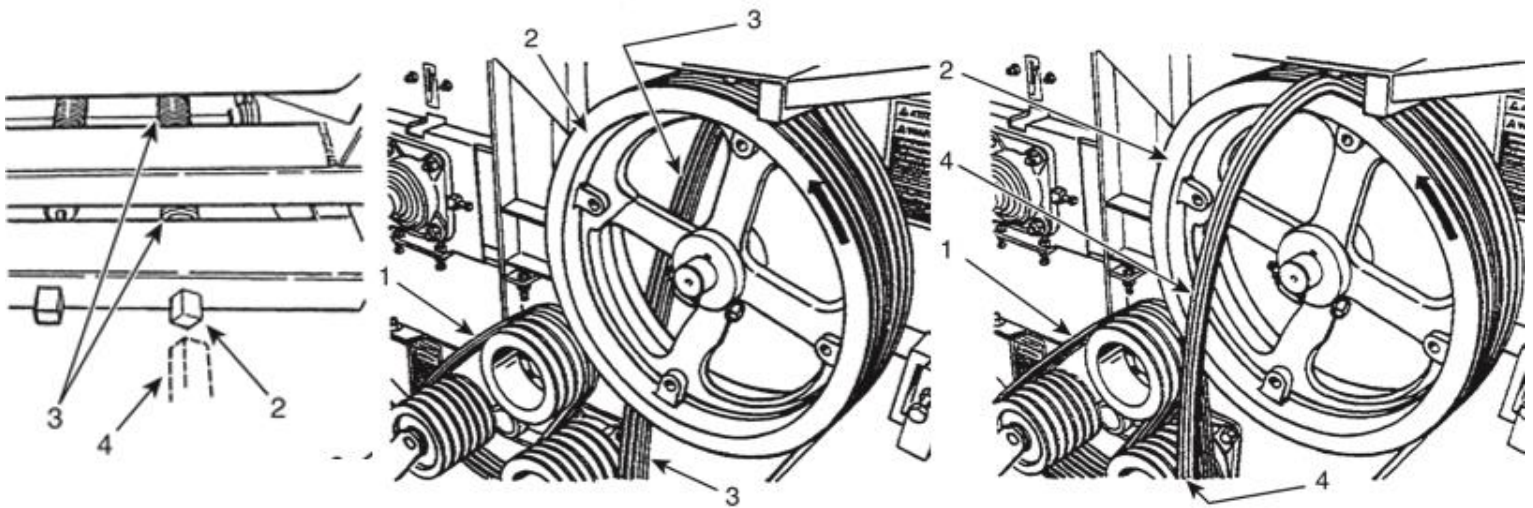

Figure 28 Belt Installation

SETUP

STEP 9 - FIGURE 29

When the belts are installed, set the tension on the binding pulley (item 4) by resetting the tension on the pulley tensioning spring (item 3). Tighten (clockwise) the right-hand rod at the rear of the harvester (item 2) to stretch the spring (item 3) with the provided square headed tool (item 1). Adjust the spacing between the spring coils to 1/16" (1,5 mm) to obtain the proper pre-tension.

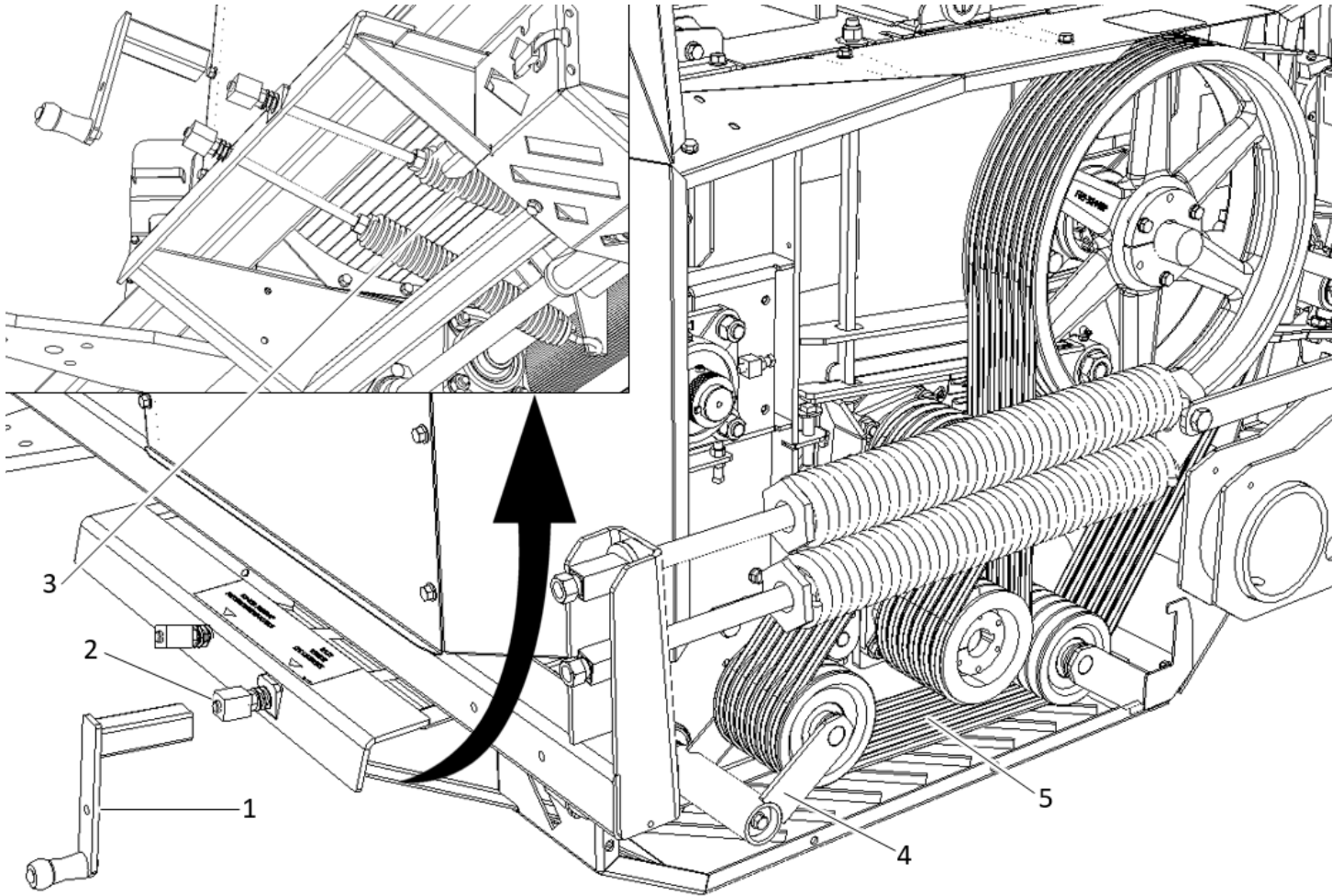

Figure 29 Belt tension

STEP 10

Ensure the processor top roll is properly greased, adjusted and the bolts properly fastened (See page Table 1, page 22). **At low PTO speed** (approx. 500 RPM), check that no part(s) are loose nor contact being made between the rollers and any other part of the processor roll assembly. Once the machine is clear to run at low speed, turn the machine at full speed for about 3 minutes and ensure the roller bearings are not overheating (maximum 60°C - 140°F).

SETUP

STEP 11 - FIGURE 30

Reinstall the accelerator belt and hook the spring back on (item 2). Use the knife guide bar (item 1) to reset the tension in the belts. (Reverse from Step 3 – Figure 23 Accelerator).

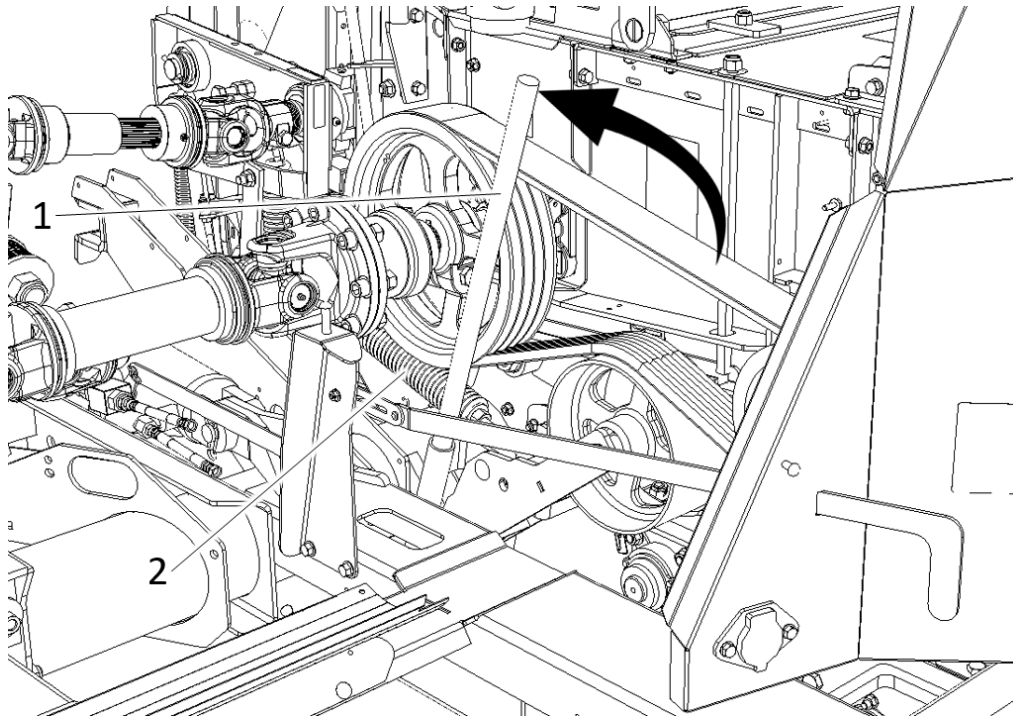

Figure 30 Accelerator tensioner

STEP 12 - FIGURE 31

Install the cylinder lock lever (item 2) and insert the locking pin (item 1). Install the tensioner locking bolt (items 3 and 4). (Reverse from Step 2 – Figure 22 Cylinder lever arm and lock bolt).

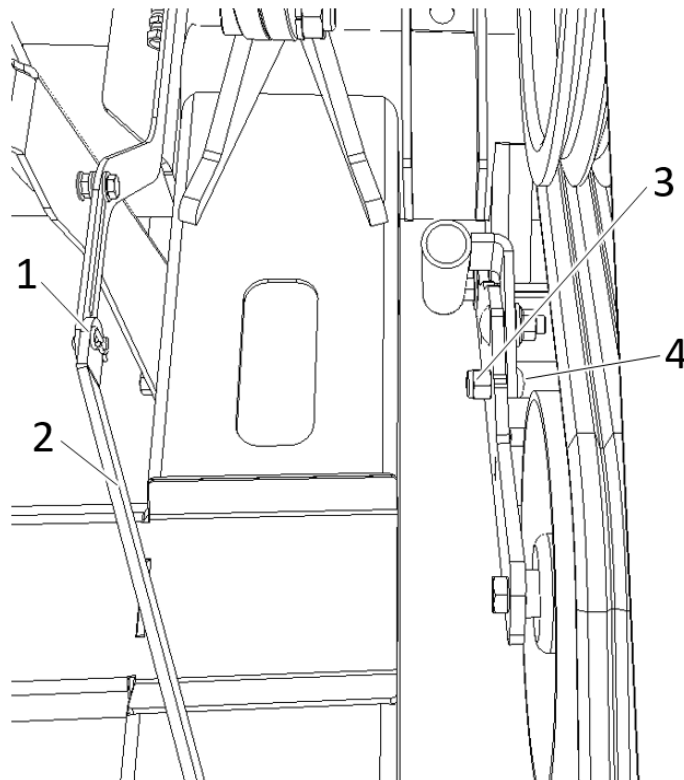

Figure 31 Cylinder lock lever and tensioner locking bolt.

SETUP

STEP 13 - FIGURE 32

Install the front grain pan (item 4) with the three - 3/8" dia. x 3/4" Long carriage bolts (item 1) and three - 3/8" flanged nuts (item 3) on the front of the pan (item 2). Ensure the nuts are installed on the outside as shown below.

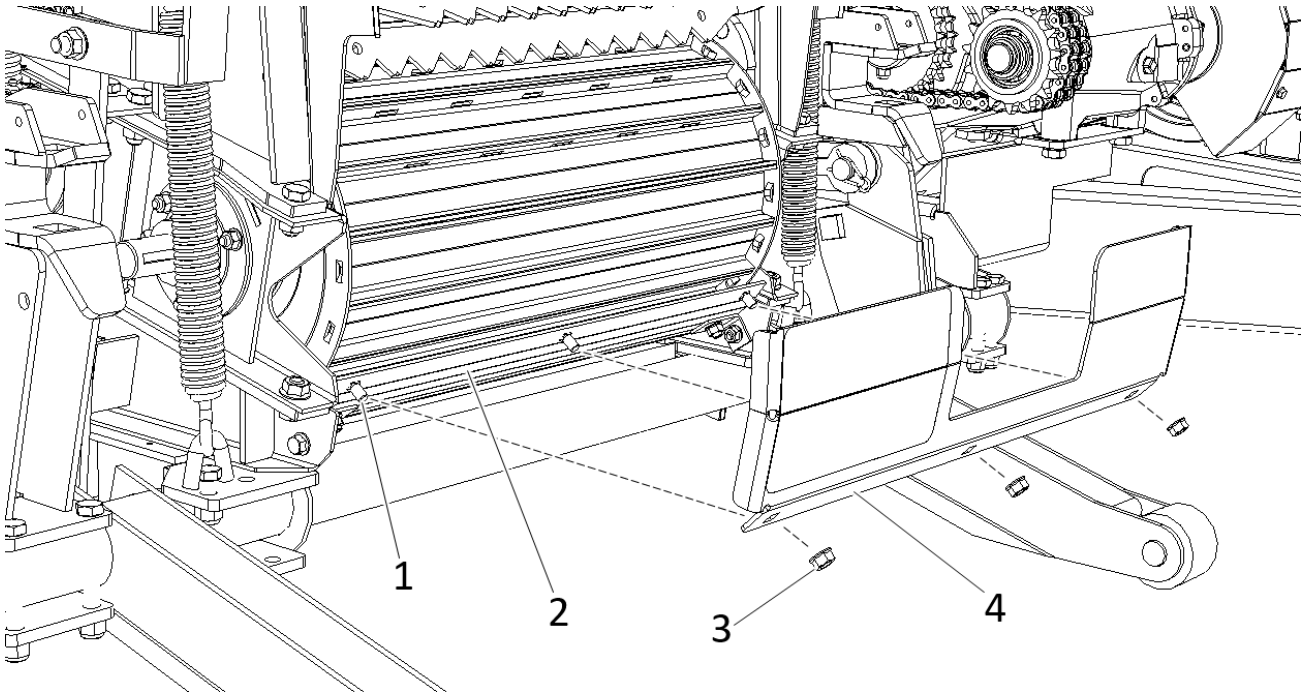

Figure 32 Front grain pan

STEP 14 - FIGURE 33

Swing the hydraulic valve manifold back in place. Fasten the bottom roll stainless plate (item 2) on the plastic guide rails with the provided wing bolts (item 1). Close the main guard. (Reverse from Step 1 – Figure 21 Main guard and valve manifold).

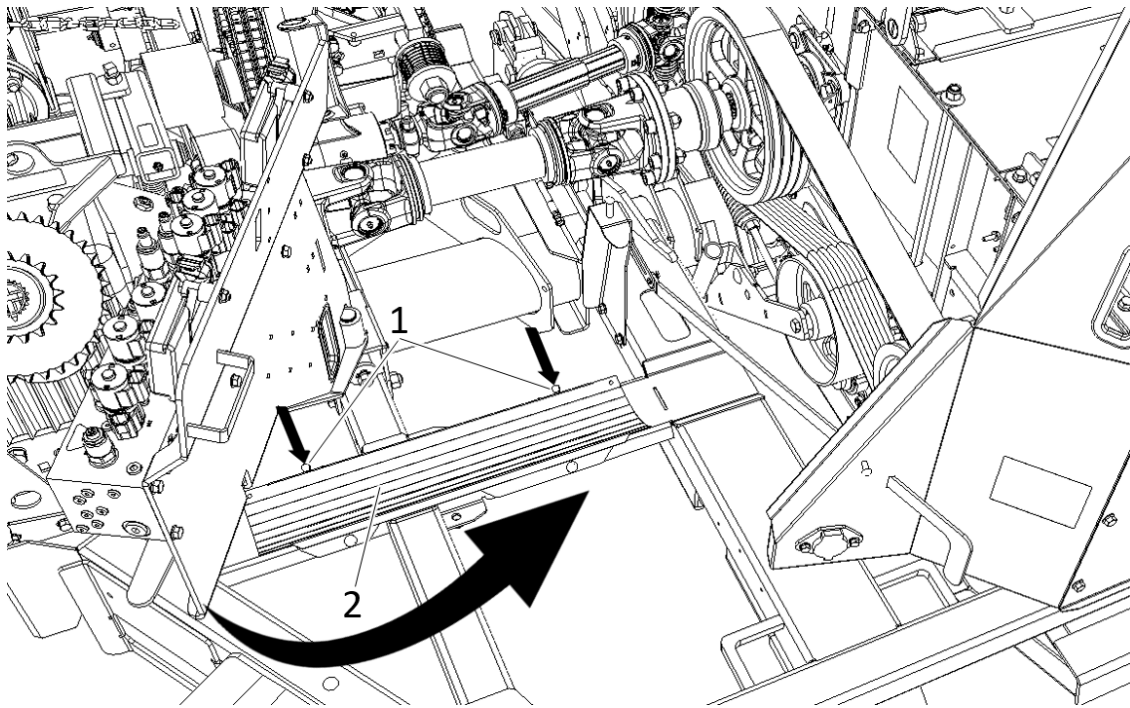

Figure 33 Stainless steel cover plate

NOTE: The harvester is now ready to harvest corn.

SETUP

CONFIGURING THE HARVESTER FOR WINDROW (HAY) HARVESTING

For hay harvesting or any other crop not requiring processor rolls, the top roll must be removed. Follow the instructions below:

STEP 1 - FIGURE 34

Open the main guard. Pull the release lever and swing the hydraulic valve manifold to free space around the accelerator belt tensioner.

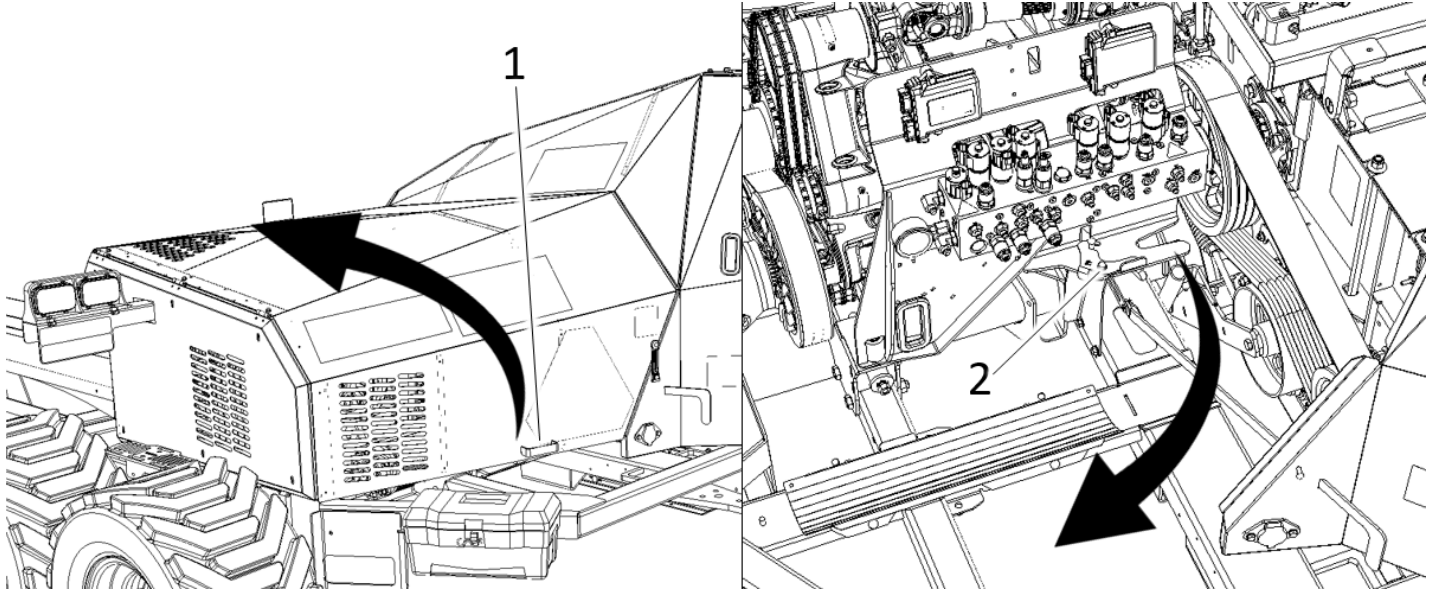

Figure 34 Main guard and valve manifold

STEP 2 - FIGURE 35

Remove the lock pin (item 1) and the header lift cylinder locking arm (item 2). Remove the bolt and nut that locks the accelerator tensioner (item 3 and 4). Store these parts temporarily in a safe place.

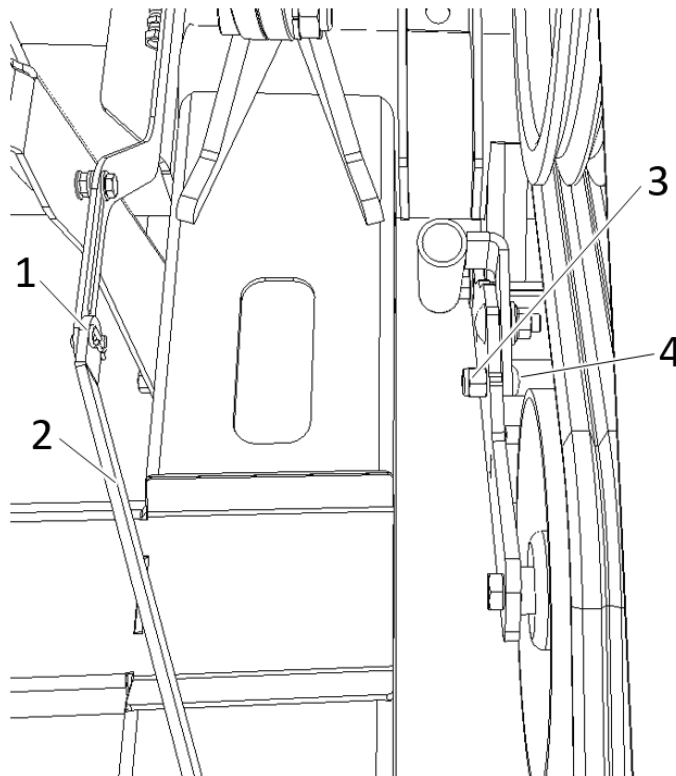

Figure 35 Cylinder locking arm and tensioner locking bolt

SETUP

STEP 3 - FIGURE 36

Use the knife guide bar stored on the machine (item 1) to unlatch the accelerator tensioner. Unhook the spring (item 2) from the front bracket to completely lower the tensioner assembly. Remove the belt to access the roller opening in the frame.

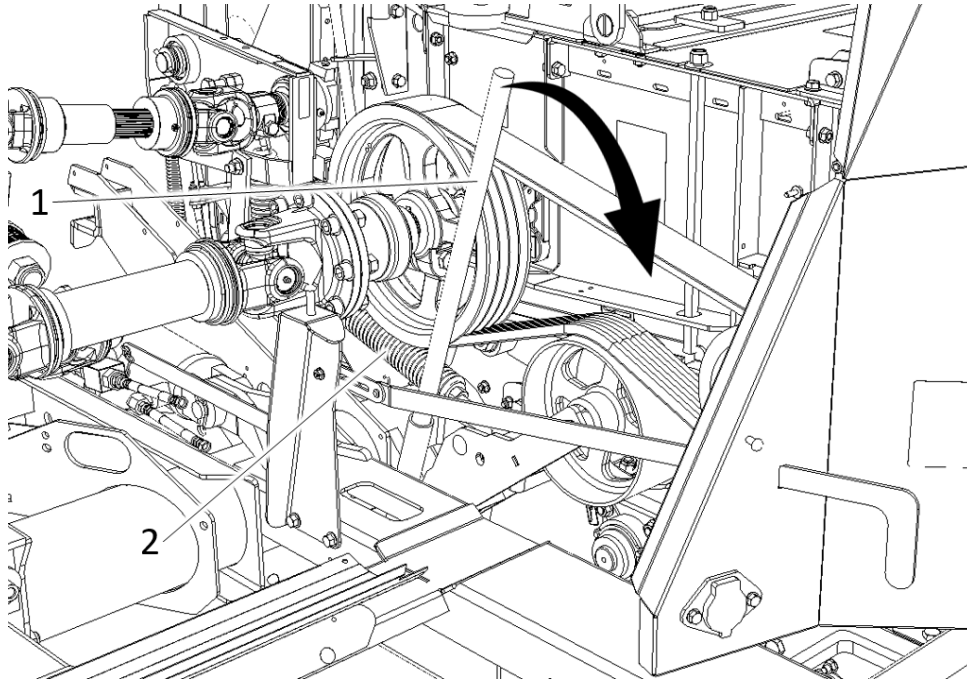

Figure 36 Accelerator tensioner



CAUTION: Work safely when you work on or operate the harvester.

STEP 4 - FIGURE 37

Open the right butterfly guard (item 1) then the side guard (item 2). Release the tension from the processor belt tensioner (item 6). To do so, turn the right-hand rod at the rear of the harvester (item 4) counter clockwise using the provided square head tool (item 5). Once loosened enough, the square end of the rod (item 4) should be loose by hand.

NOTE: Remove tension on the right-hand side rod only.

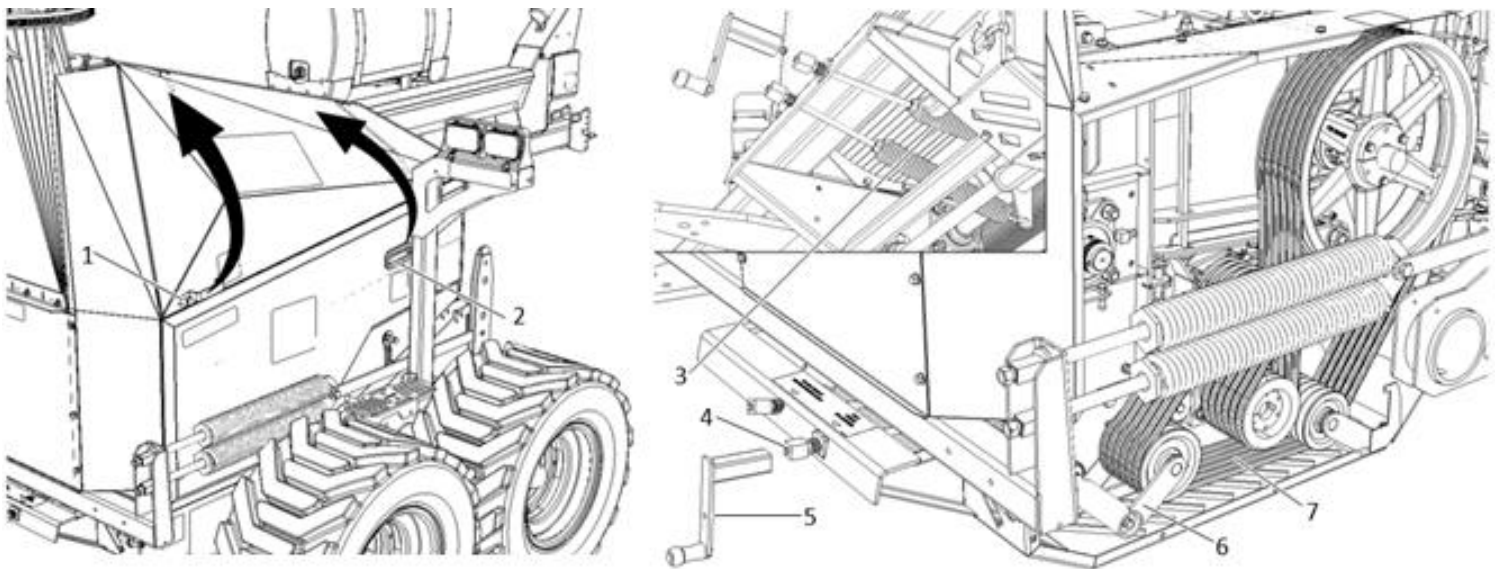

Figure 37 Guards and processor rolls

SETUP

STEP 5 - FIGURE 38

The drive pulley (item 2) has 6 slots for 6 belts. If you consider the pulley slot closest to the machine body #6 and furthest from the machine body #1, remove the **six** belts, one belt at a time, in the following order:

Start on the drive pulley side furthest from the machine body always rotating clockwise as shown in Figure 38 Removing the belts.

First remove belt #1, #2 and then #3 (item 3).

For the remaining 3 belts, continue to rotate the drive pulley clockwise. Remove belts #6, #5 and end with #4 (item 4).

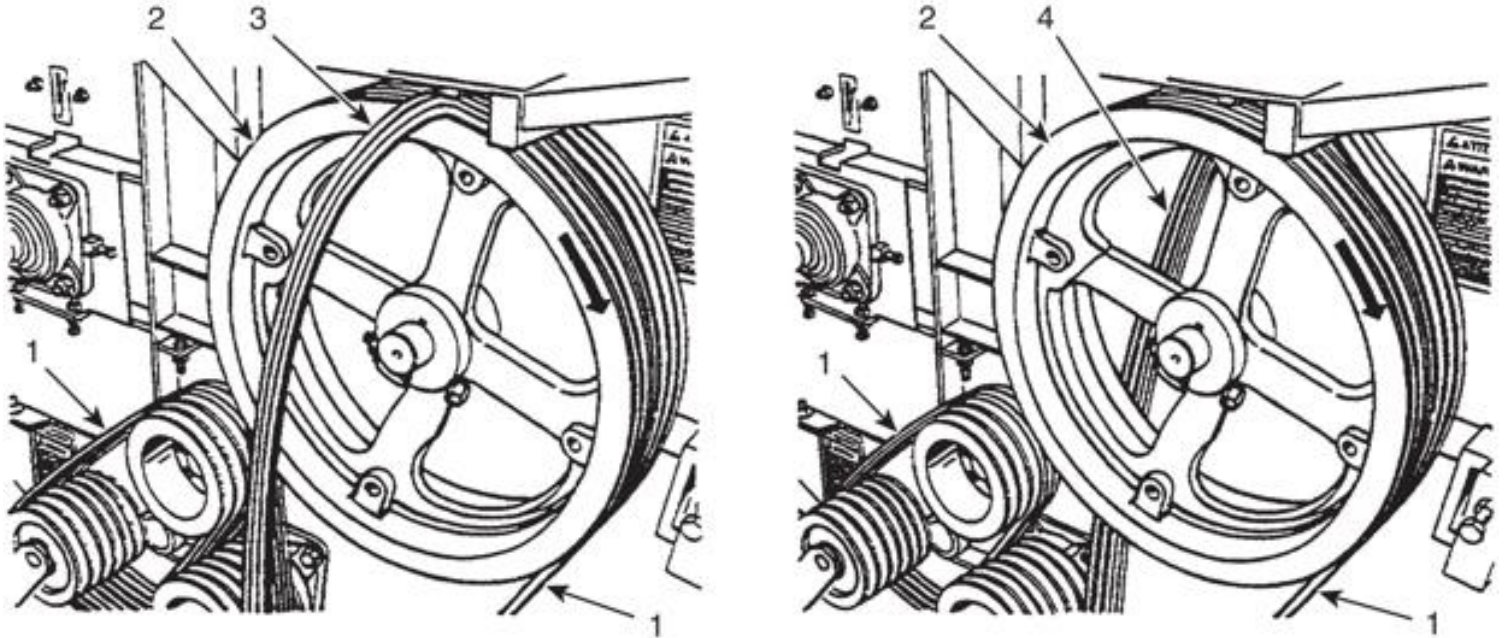

Figure 38 Removing the belts

STEP 6 - FIGURE 39

Unbolt the top roller bearing plates left (item 1) and right (item 2).

Each bearing plate is supported using: **2ea - 1/2" dia. X 1" long flange bolts (4 total).**

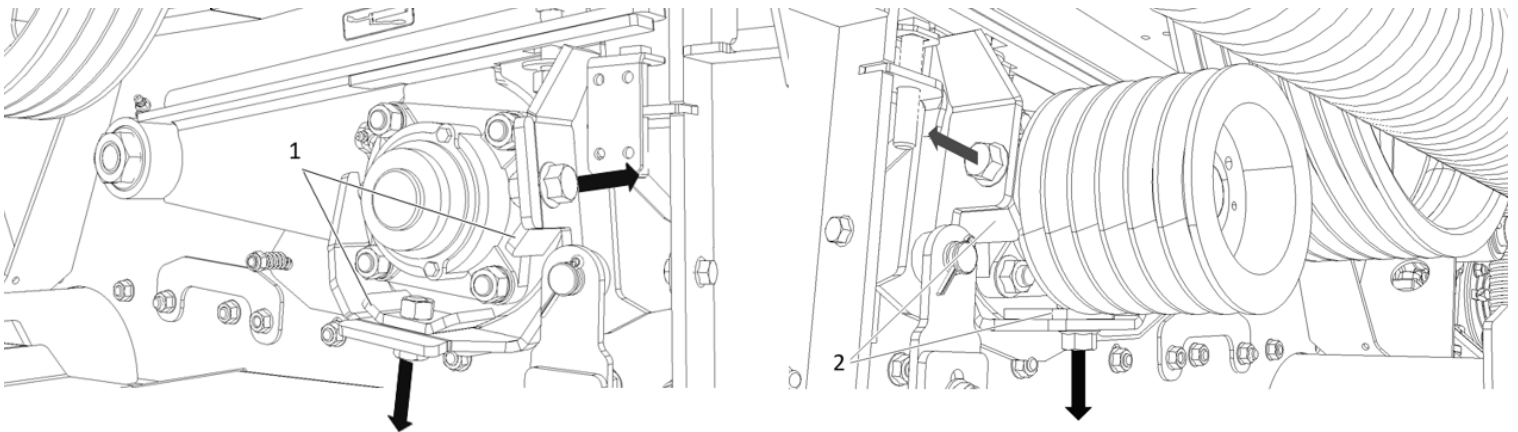

Figure 39 Bearing supports

SETUP

STEP 7 - FIGURE 40

Remove the top roll assembly (item 3) and slide it onto the plastic guides. Grease the roller splines to prevent rust formation. Align one of the fastening holes with the stud (item 4) to prevent it from sliding laterally. Install the rubber cover (item 2) on the roll and clamp it down in place with the holding strap (item 1).

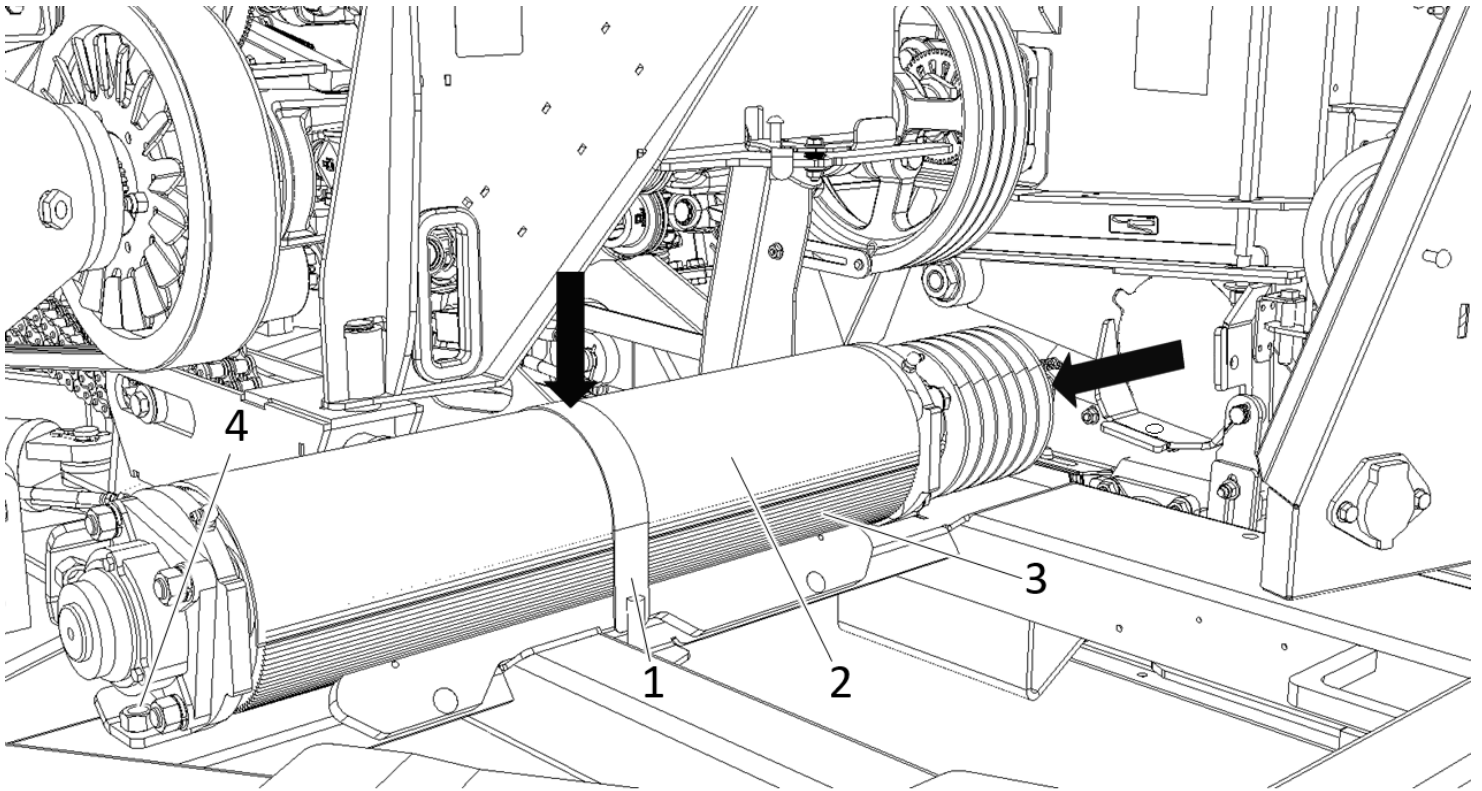

Figure 40 Clamping the top processor roll

STEP 8 - FIGURE 41

Install the 2 cover plates, left (item 1) and right (item 2) using the same 1/2" dia. X 1" long flange bolts removed during Step 6.

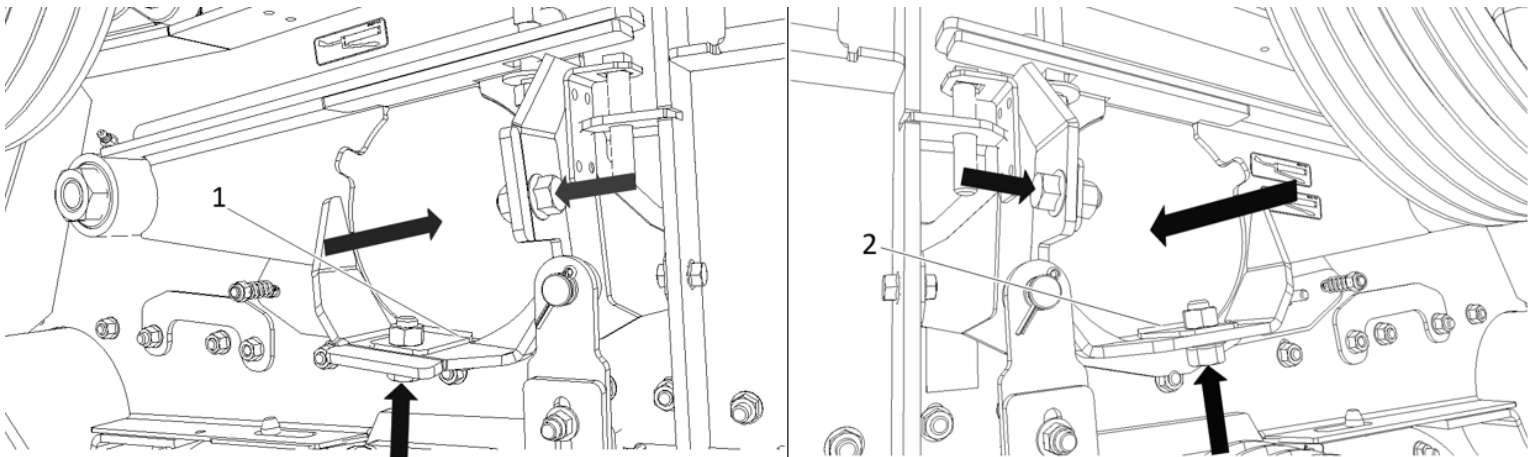

Figure 41 Cover plates

SETUP

STEP 9 - FIGURE 42

Support the processor roll unit and loosen the processor roll fastening bolts at the rear (left and right) (item 1). Lower the processor roll unit carefully to gain access to the roller assembly. Clean the channel pans and the bottom roll (item 3) and grease the bottom roller splines to prevent rust formation. Install the stainless cover (item 2) over the roll (item 3), as shown. Set the belts (item 4) in the bottom of the frame as shown.

NOTE: Do not modify the roller adjustments.

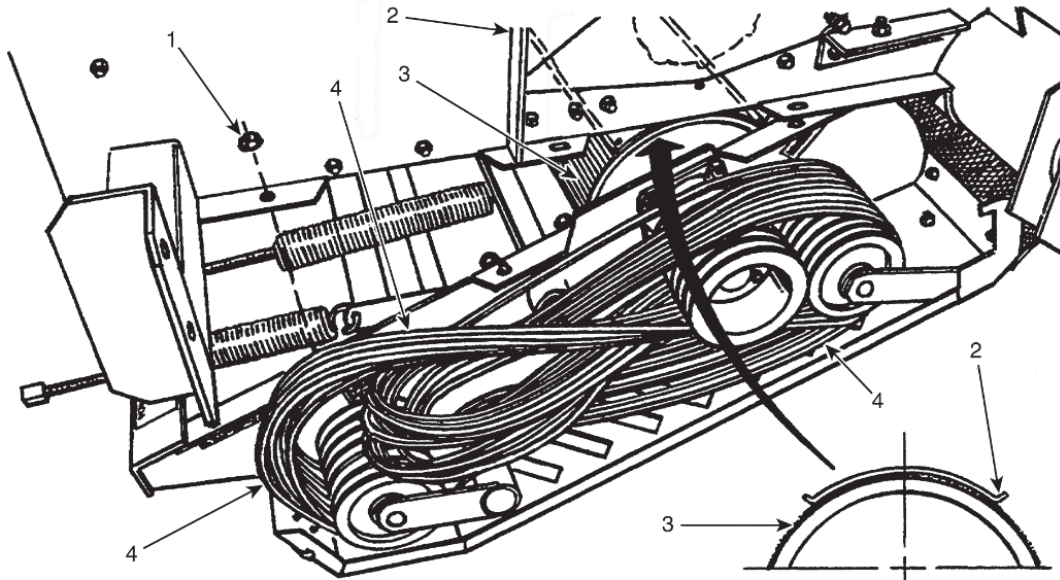

Figure 42 Processor roll unit

STEP 10 - FIGURE 43

Lift the processor roll unit (item 1) while making sure the stainless cover (item 3) sits properly **under** the channel half-pans (item 4) as shown in FIGURE 43 HALF-PAN ALIGNMENT. Replace and tighten the frame bolts (item 2) to proper torque (See Table 1, page 22).

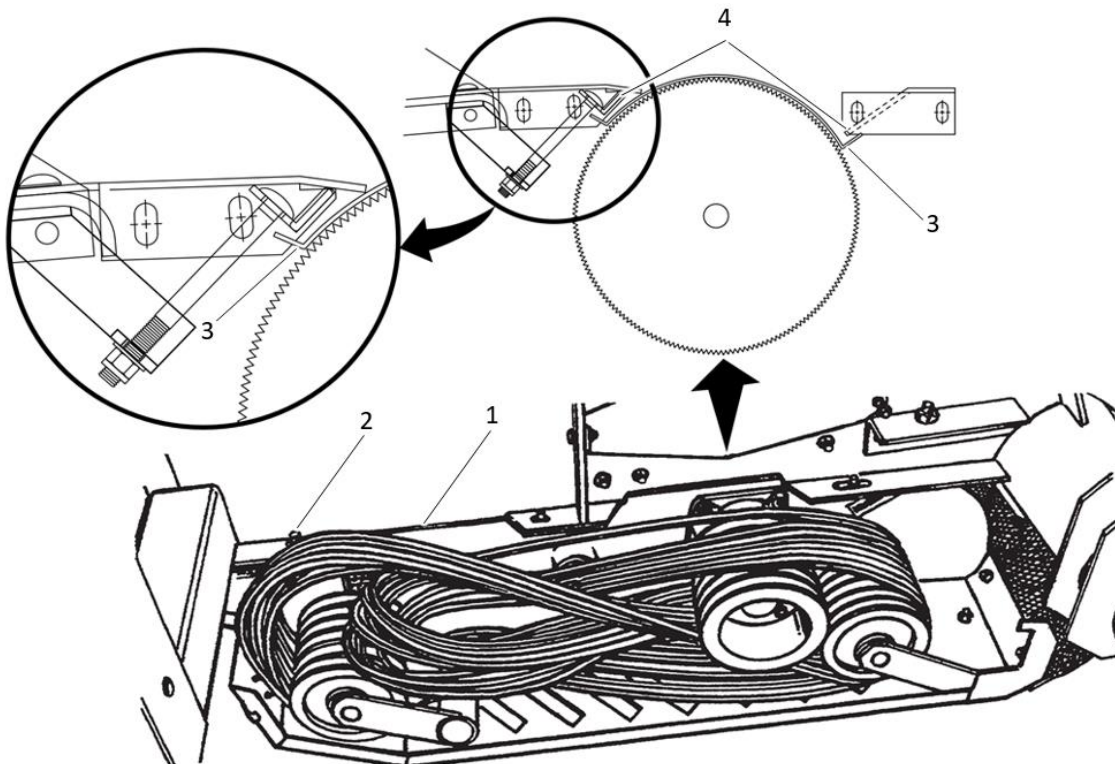

Figure 43 Half-pan alignment

SETUP

STEP 11 - FIGURE 44

Reinstall the accelerator belt and hook the spring back on (item 2). Use the knife guide bar (item 1) to reset the tension in the belts. (Reverse from Step 3 – FIGURE 36 ACCELERATOR).

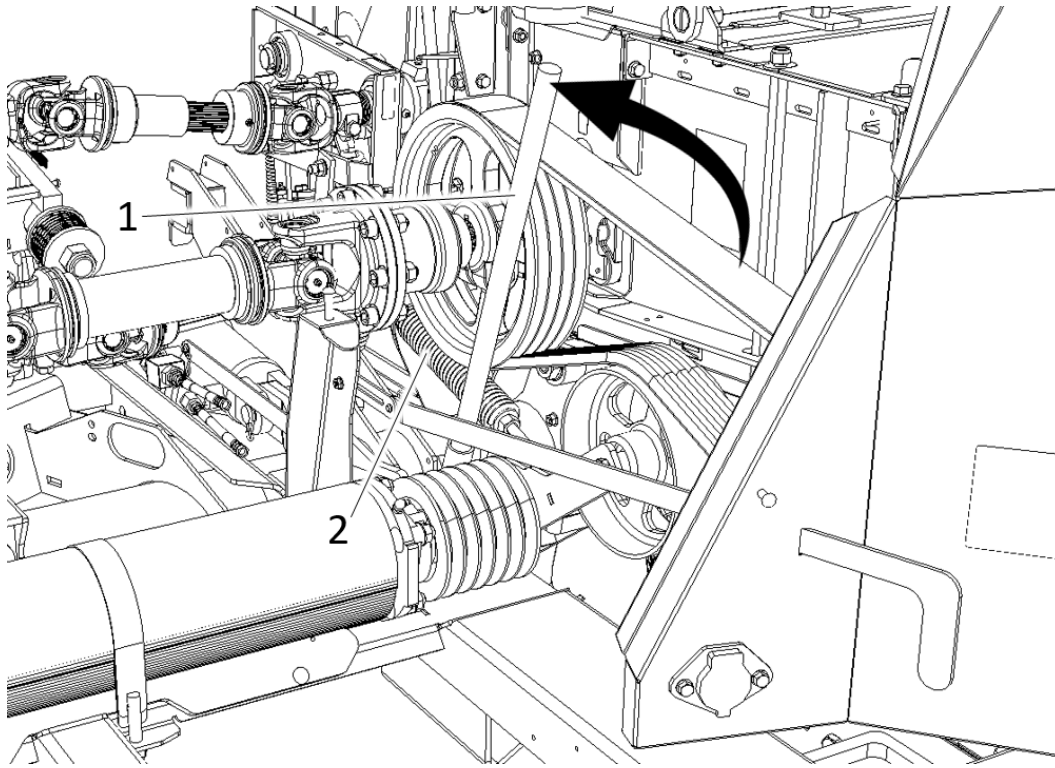

Figure 44 Accelerator belt tensioner

STEP 12 - FIGURE 45

Install the cylinder lock lever (item 2) and insert the locking pin (item 1). Install the tensioner locking bolt (items 3 and 4). (Reverse from Step 2 – Figure 35 Cylinder locking arm and tensioner locking bolt).

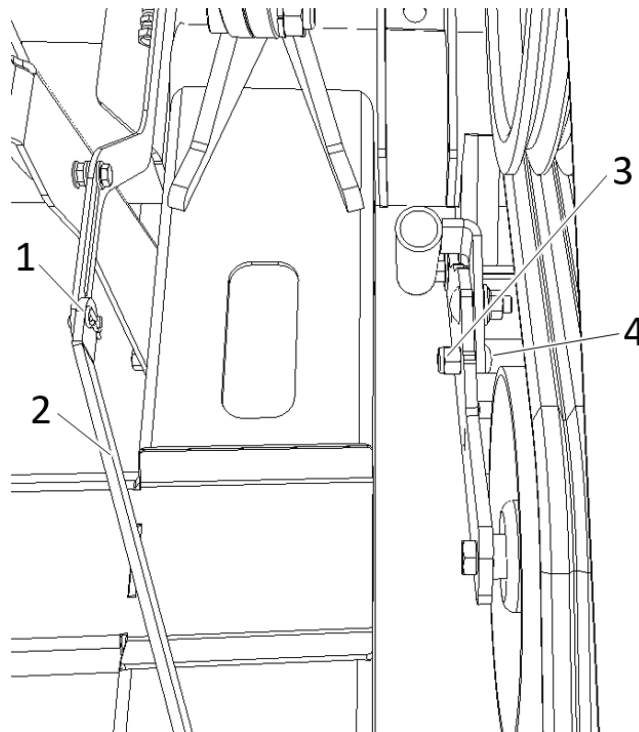

Figure 45 Locking lever and tensioner locking bolt

SETUP

STEP 13 - FIGURE 46

Swing the hydraulic valve manifold back in place.

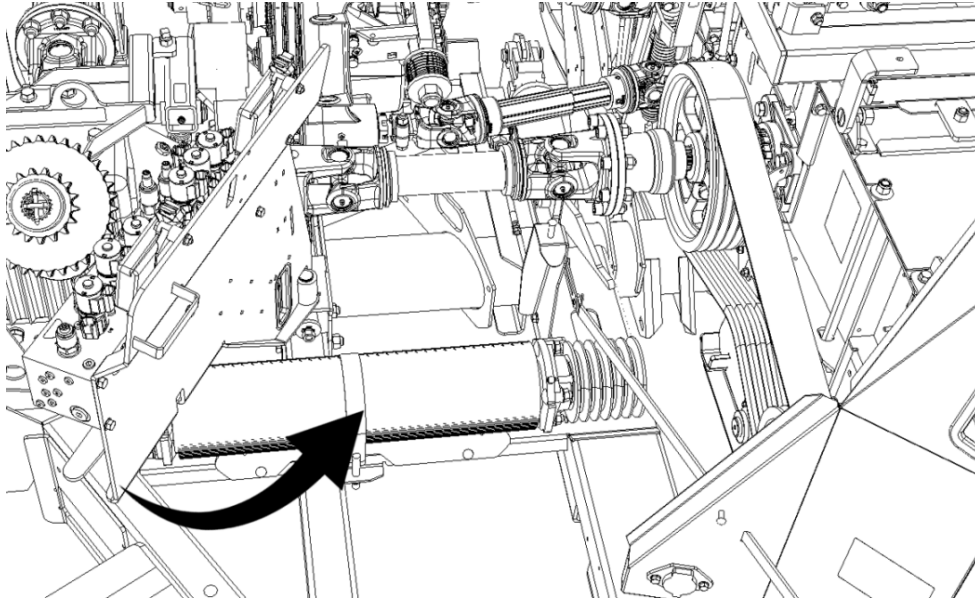

Figure 46 Valve manifold

STEP 14 - FIGURE 47

Remove the front grain pan (item 4) with the three 3/8" dia. x 3/4" Long carriage bolts (item 1) and three 3/8" flanged nuts (item 3) on the front pan (item 2). Store these parts until they are needed again.

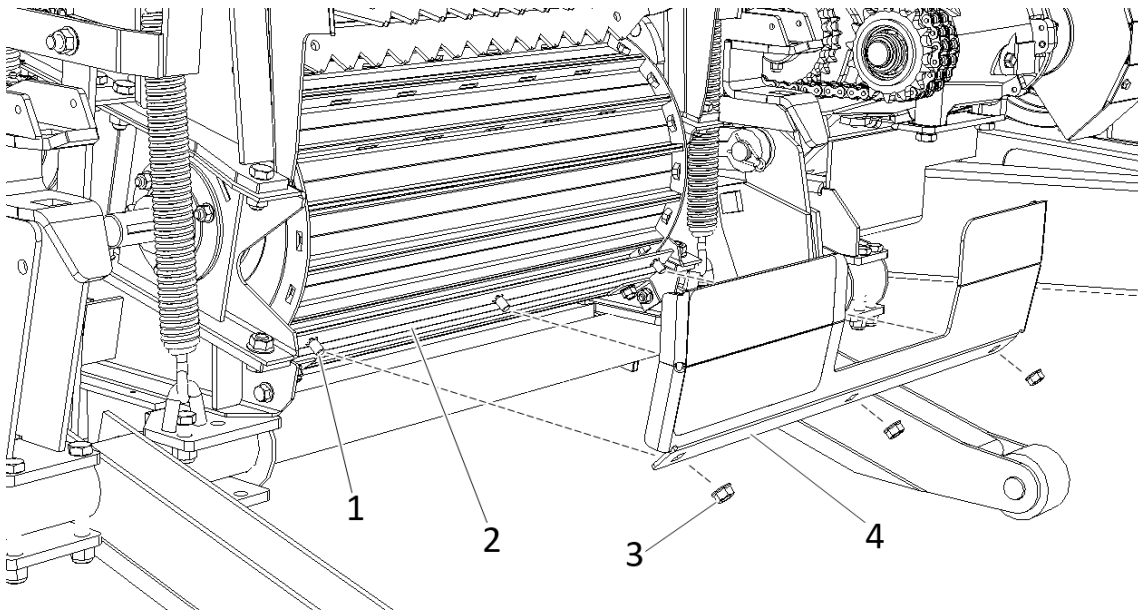

Figure 47 Removing the front grain pan

STEP 15

At low PTO speed (approx. 500 RPM), check that no part(s) are loose nor contact being made between the rollers and any other part of the processor roll assembly. Once the machine is clear to run at low speed, turn the machine at full speed for about 3 minutes and ensure the roller bearings are not overheating (maximum 60°C - 140°F).

Replace the side guard (item 2, FIGURE 37), the right butterfly guard (item 1, FIGURE 37) and the main guard (item 1, FIGURE 34) and lock.

NOTE: The harvester is now ready for hay harvesting.

SETUP

SETTING THE LENGTH OF CUT

FIGURE 48

Two factors will determine the length of cut:

1. The number of knives on the cutter head.
2. The length of cut (LOC) sprocket (item A) driving the feed rolls. LOC L (Low speed) or LOC H (High speed).

Refer to the following chart for the appropriate settings. Optional length of cut (LOC) range LOC « L » and LOC « H » are factory installed but can be modified from one to the other with conversion kit available from your dealer.

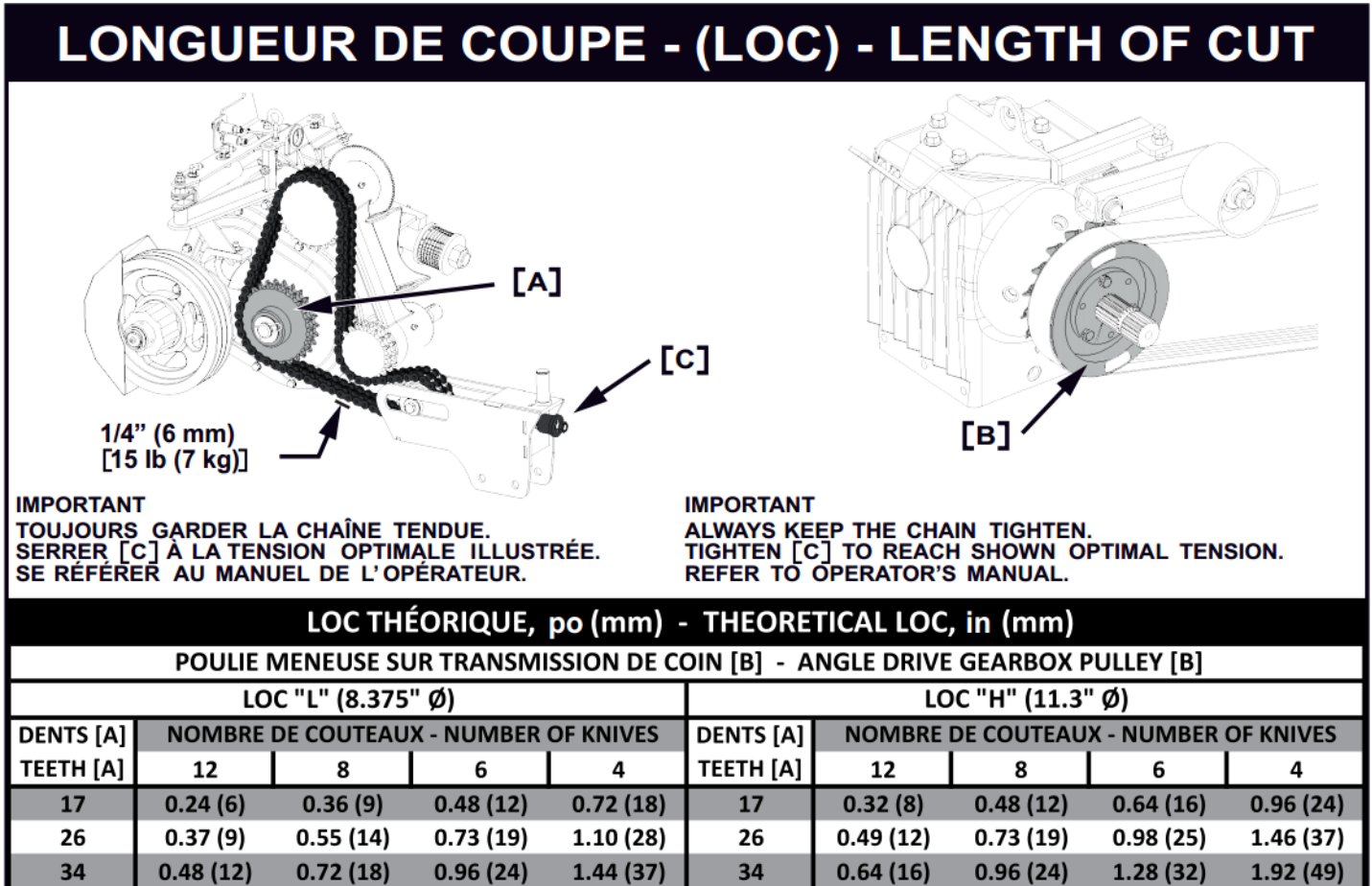

Figure 48 Length of cut chart



WARNING: Stop the PTO and tractor engine before adjusting the harvester. Refer to the SAFETY RULES on page 12.

SETUP

PROCEDURE TO MODIFY THE LENGTH OF CUT

STEP 1 - Figure 49

Open the main guard.

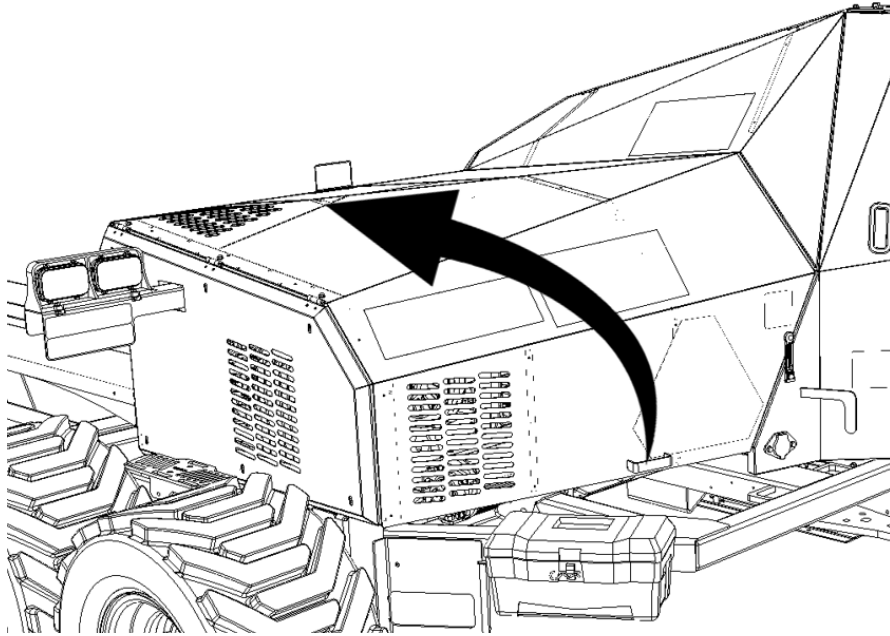

Figure 49 Open the main guard

STEP 2 – FIGURE 50

Completely remove the chain tension (item 1) by loosening the tensioning rod (item 2).

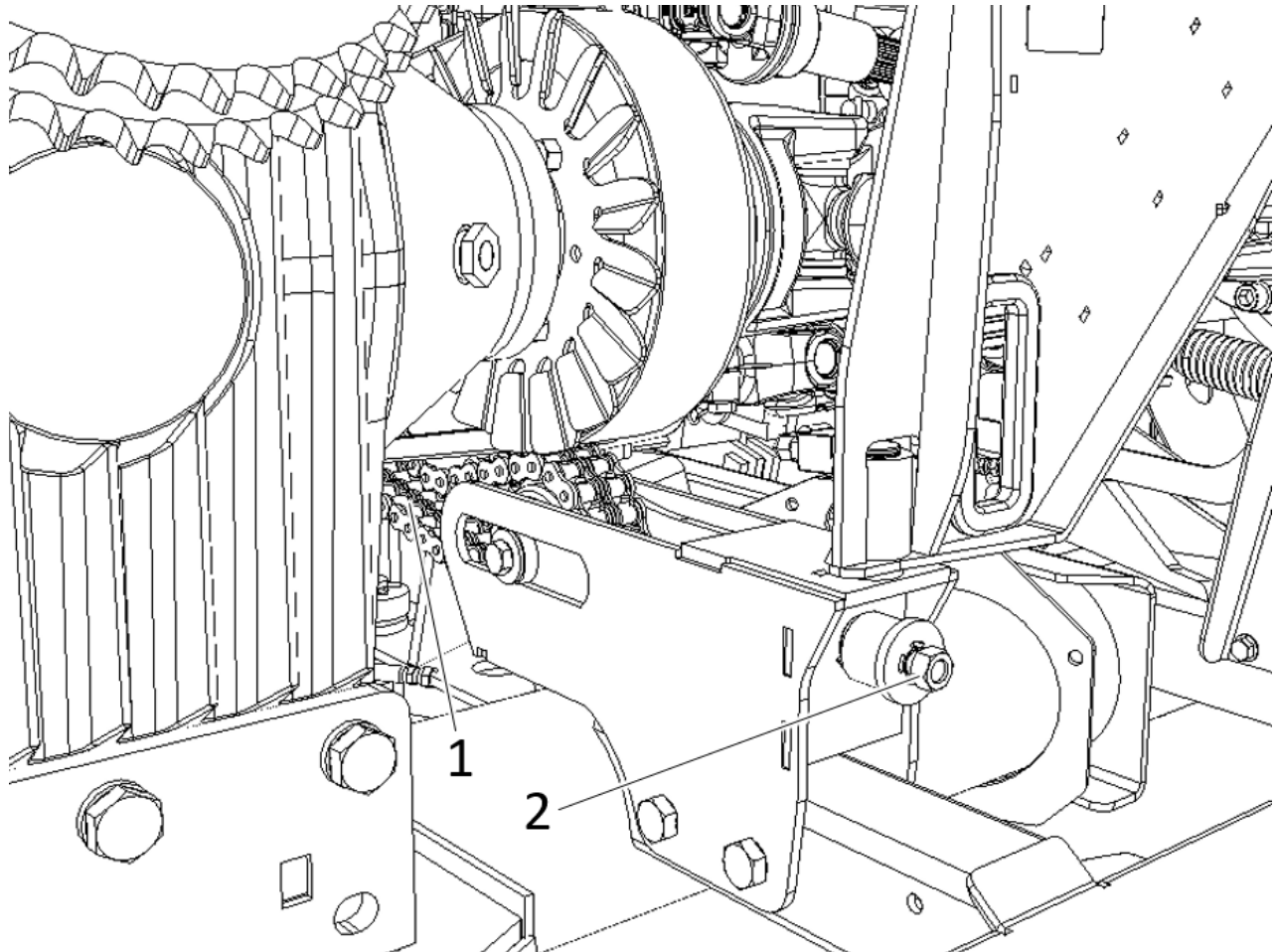

Figure 50 Chain tensioner

SETUP

STEP 3 - FIGURE 51

Remove the quick link of the chain before attempting to remove the sprocket. Remove the LOC double sprocket (item 1), by removing the spring clip (item 2) and washer (item 3). You may need to clean the shaft with fine sand paper to remove paint or dirt before the sprocket can be removed.

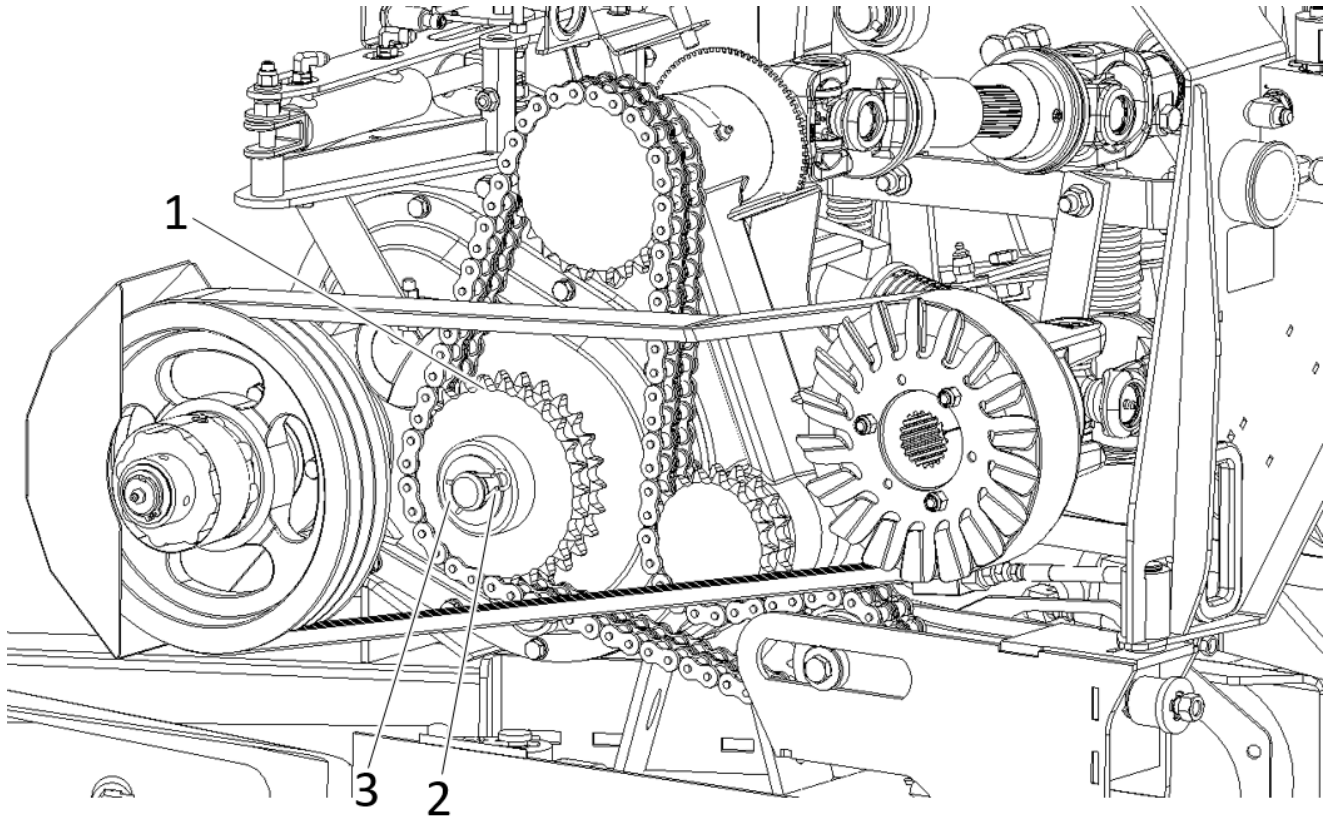

Figure 51 Double sprocket

STEP 4

Clean the shaft with fine sandpaper and apply anti-seizing lubricant on the shaft. Determine the appropriate sprocket from the table in Figure 48. Install the sprocket and replace the washer(s) (item 3) and clip (item 2).

STEP 5 - FIGURE 50

Reset the tension on the chain (item 1) by tightening the tensioning rod (item 2). Tighten until the proper tension is achieved (see Figure 48). Close the main guard.

NOTE: Three sprockets are included with the harvester: 17, 26 and 34 tooth.

SPOUT EXTENSION REMOVAL

FIGURE 52

For harvesters equipped with a *Stinger* spout extension it is possible, at any time, to change the drop configuration by removing or adding the "Stinger" extension to switch from side loading to rear loading or vice versa.

NOTE: For the first installation of the chute extension, see the installation manual provided with the purchase.



CAUTION: Always keep the machine coupled to the tractor when operating the spout.

STEP 1

1. Rotate the spout so it is facing the back of the machine, then lower it completely.
2. Disconnect the hydraulic hoses (item 1), the electric cable of the deflector light (Item 2) and the camera (Item 3) Figure 52 Spout conversion.
3. Protect all tips of all hydraulic hoses to prevent contamination, at all times.

SETUP

STEP 2

1. Remove the two bolts (item 4) on the deflector module. The module is equipped with hooks (Item 5) that will keep it in place during this operation.
2. Securely fasten the module with lifting straps and lift it to remove it.

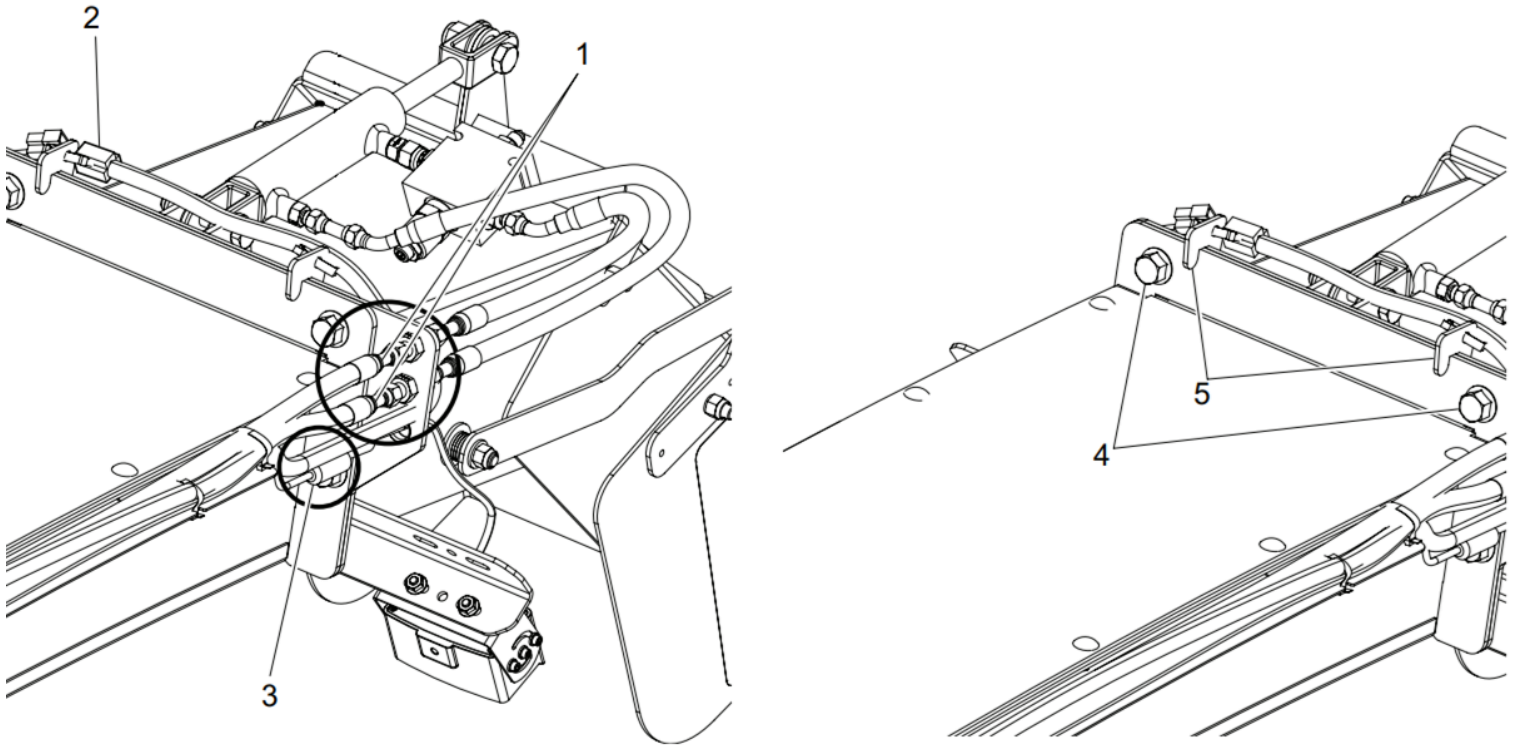

Figure 52 Spout conversion

STEP 3

1. Fasten the lifting straps on each side of the reinforcement brackets of the intermediate section to lift and remove the middle section Figure 53 : Stinger spout conversion.
2. Repeat steps 1 and 2, but this time at the base of the intermediate section.
3. Reinstall the deflector module on the base of the spout and reconnect all hoses and electrical connections.

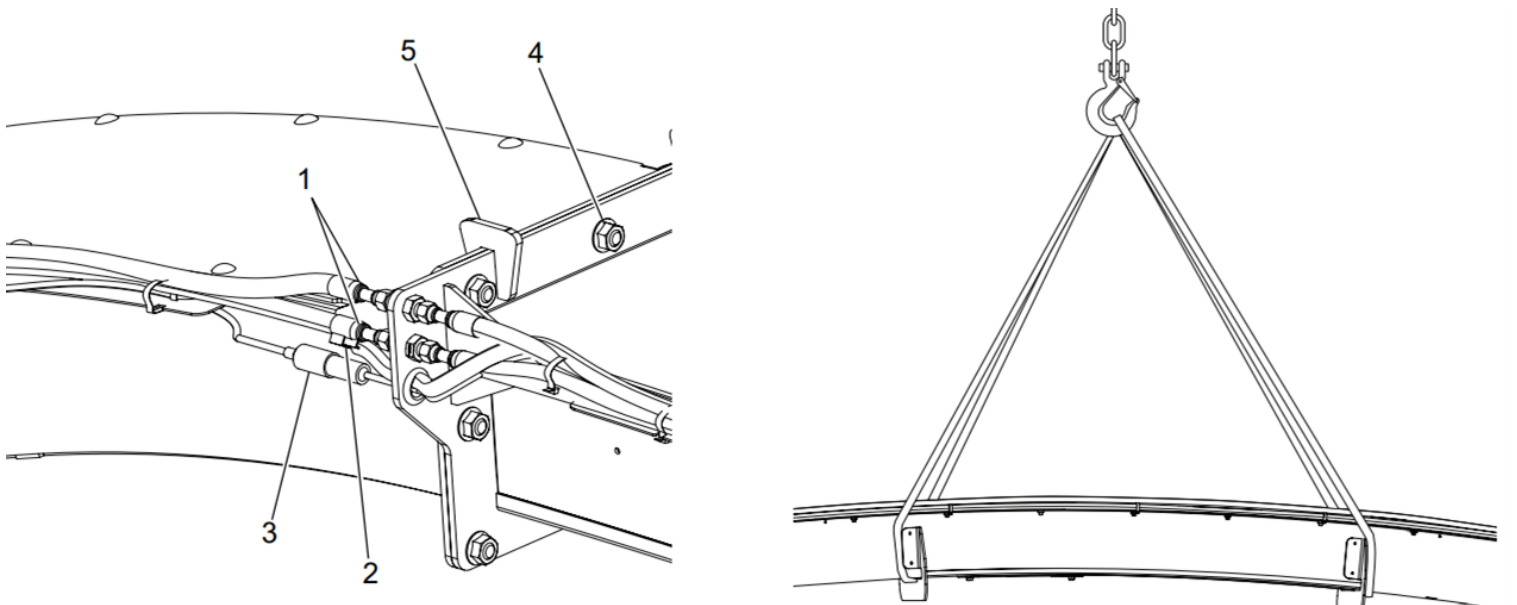

Figure 53 : Stinger spout conversion

SETUP

HEADER INSTALLATION

Ensure the harvester and header rest on a flat and level surface. The headers are equipped with a single point lift (item 1, Figure 54 Header lift point) allowing the use of a lift chain and hook with a minimum lifting capacity of 3000 lbs (1350 kg) for easy maneuvering.

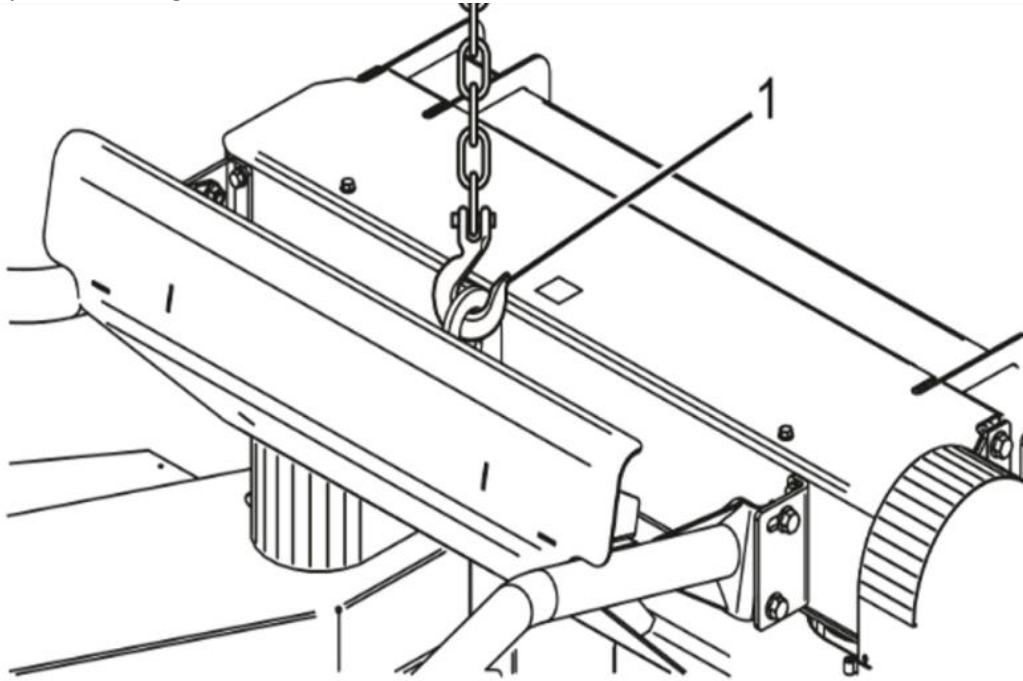

Figure 54 Header lift point



DANGER: NEVER operate the harvester without a header installed.

STEP 1 - FIGURE 55

Swing the tongue open (item 2) (see arrow) and position the suspension spring (item 3) accordingly. Refer to page HEADER SUSPENSION (HEADER SUSPENSION) section for proper functioning of the suspension according to the header used. When using a 4-row corn head, install the 1 1/4" stroke limiting pin (item 4) provided with the harvester to avoid contact between the header and the harvester.

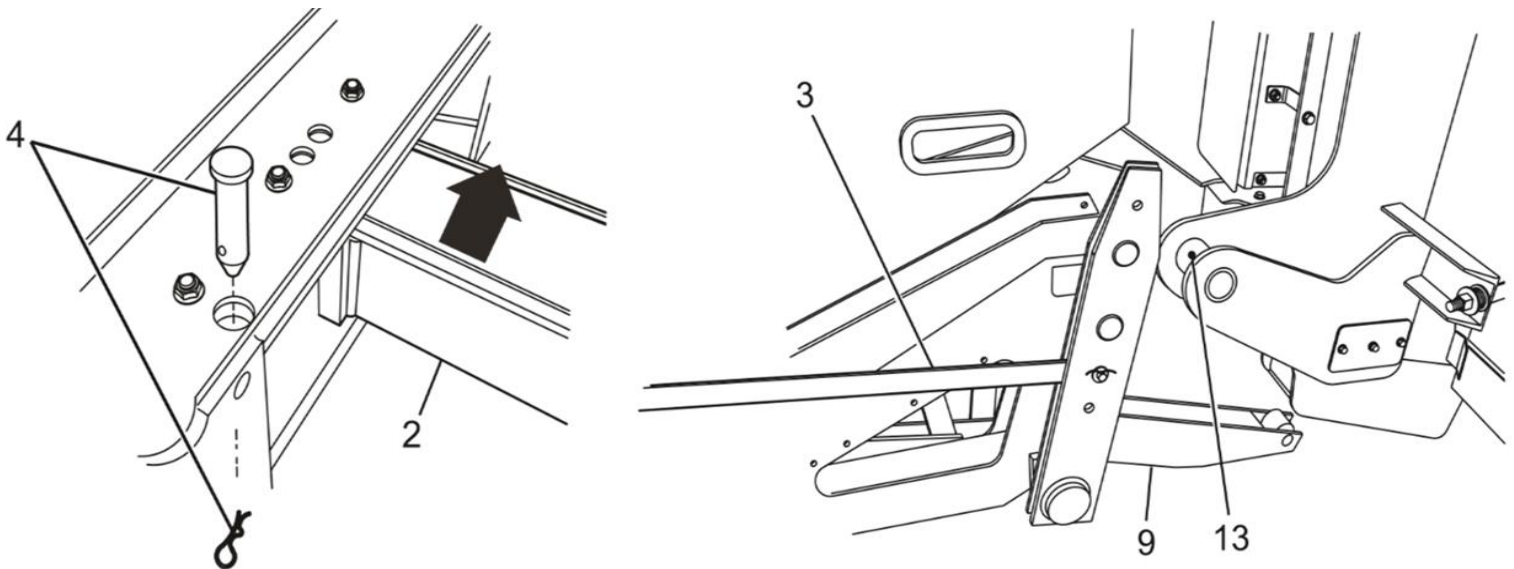

Figure 55 Stroke limit pin and header lifting mechanism

SETUP

STEP 2 - FIGURE 56

Move the harvester towards the header slowly while ensuring the pivots receptacles (item 12) are aligned with the header brackets (item 13, Figure 56 Header attach points).

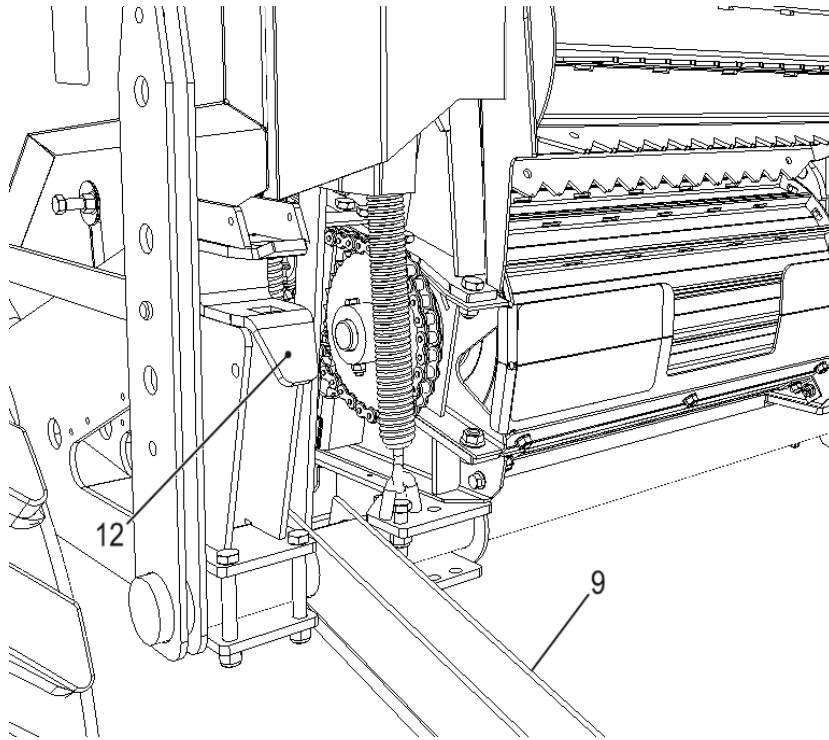

Figure 56 Header attach points

STEP 3 - FIGURE 57

Align and adjust the 2 feed roll throat guards (items 14) to fit between the harvester throat sides and feed rolls.

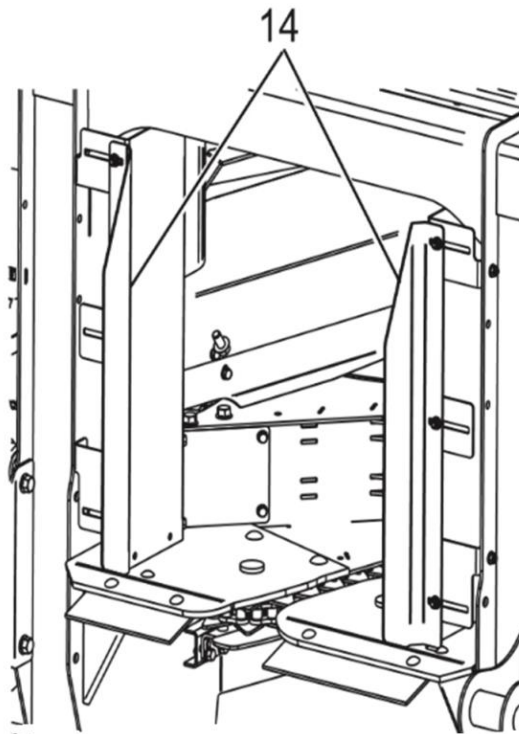

Figure 57 Feed roll guards



CAUTION: If the throat sides (item 14) of Hay or Corn crop attachments are bent or damaged, it is necessary to repair them so they will not come in contact with the feed rolls.

SETUP

STEP 4 - FIGURE 58

When the header is installed on the harvester, install the square locking pins in place (item 10) and the safety locks clips (item 11) on both sides.

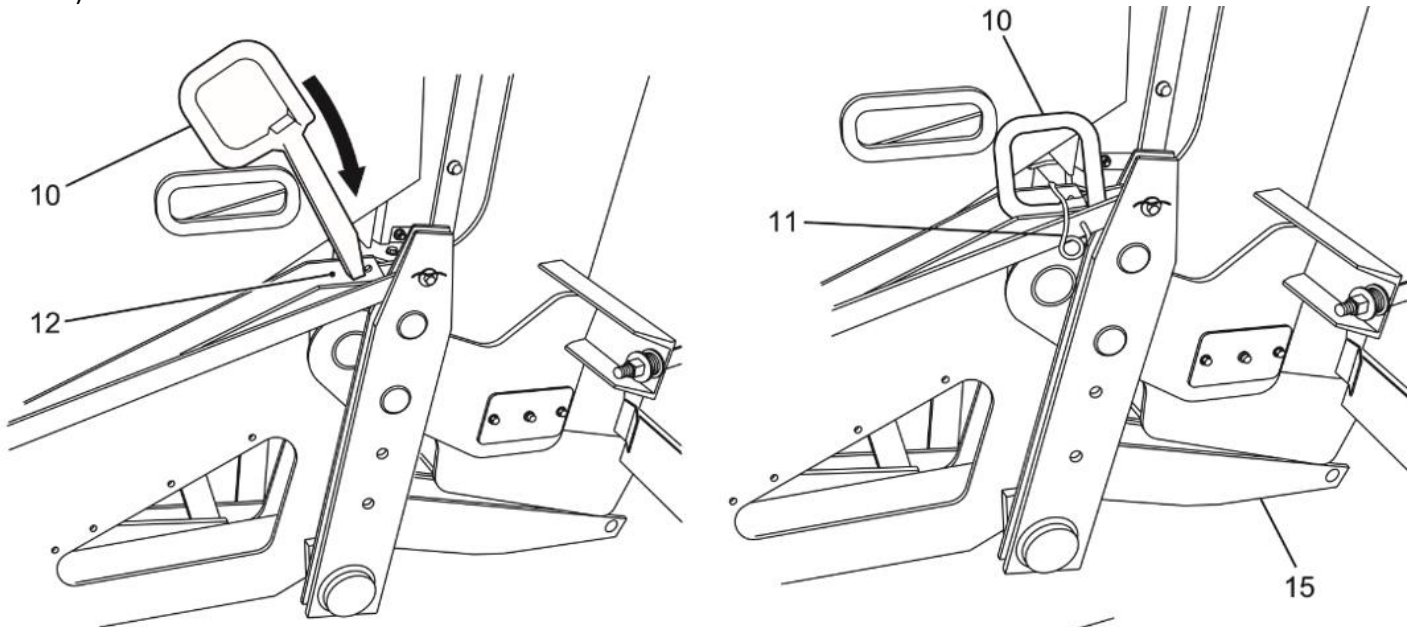

Figure 58 Header locking pins

STEP 5 - FIGURE 59

Use the following drive chain setup for the corresponding head:

Corn Head: Use the provided #80 X 35" long with a single #80 connecting link (item 16).

Windrow Pickup: Use the provided #80 X 35" long with one #80 connecting link **and** one #80 half link (item 17).

NOTE: All parts required to install headers on the harvester are located in the toolbox.

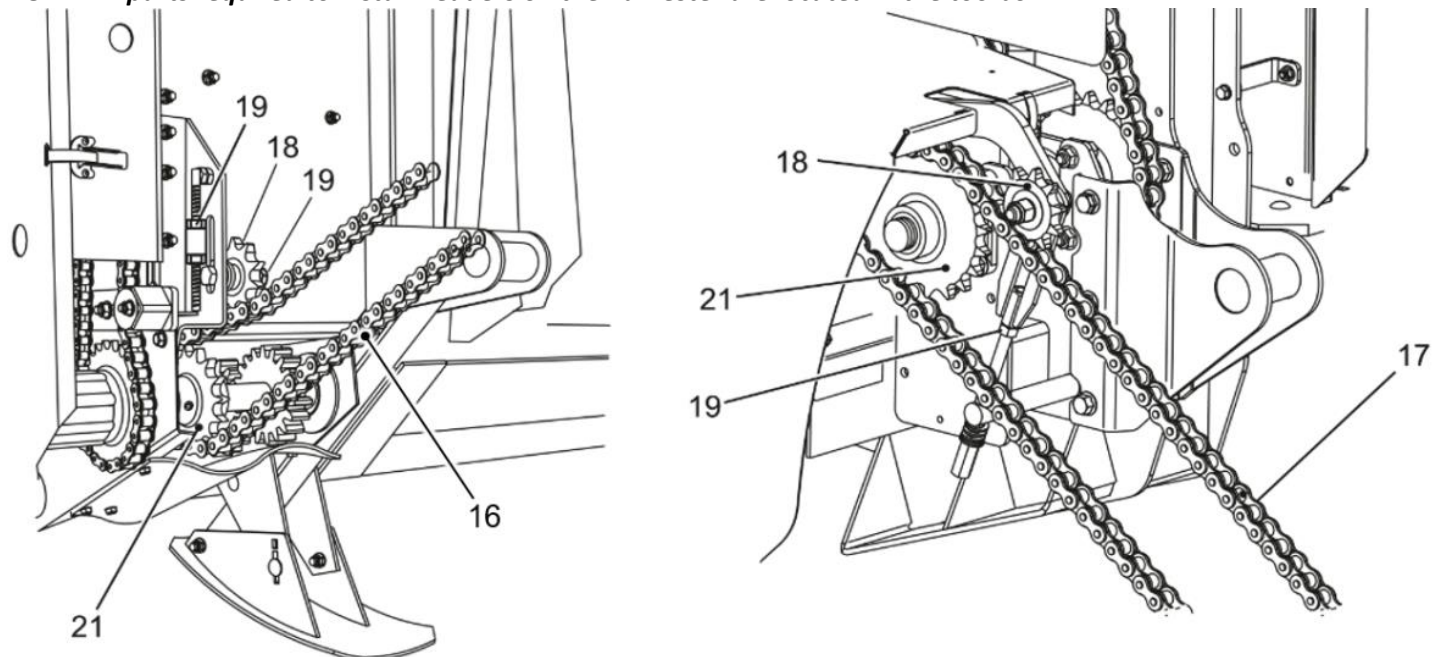

Figure 59 Drive chain

STEP 6 - FIGURE 59

Lift the head in operating position (item 15, Figure 58). Install the chain by routing it under the tensioner (item 18). Position the header sprocket (item 21) on the shaft to align it with the harvester drive sprocket. Adjust the chain tension to 6 mm (1/4in) of deflection for 7 kg (15lb) force. Tighten the tensioner in place.

NOTE: Always lower the header when the harvester is not in used or for storage.

SETUP

HEADER SUSPENSION

STEP 1 - FIGURE 60

The suspension springs (item 1, Figure 60 Header lift springs) function is to control the header ground pressure. In general, the tension must be set to result in a weight of about 35 kg (75 lb) at the front of the header. The spring adjustment varies from one header to another.

NOTE: A 15/16" socket can also be used for a faster adjustment.

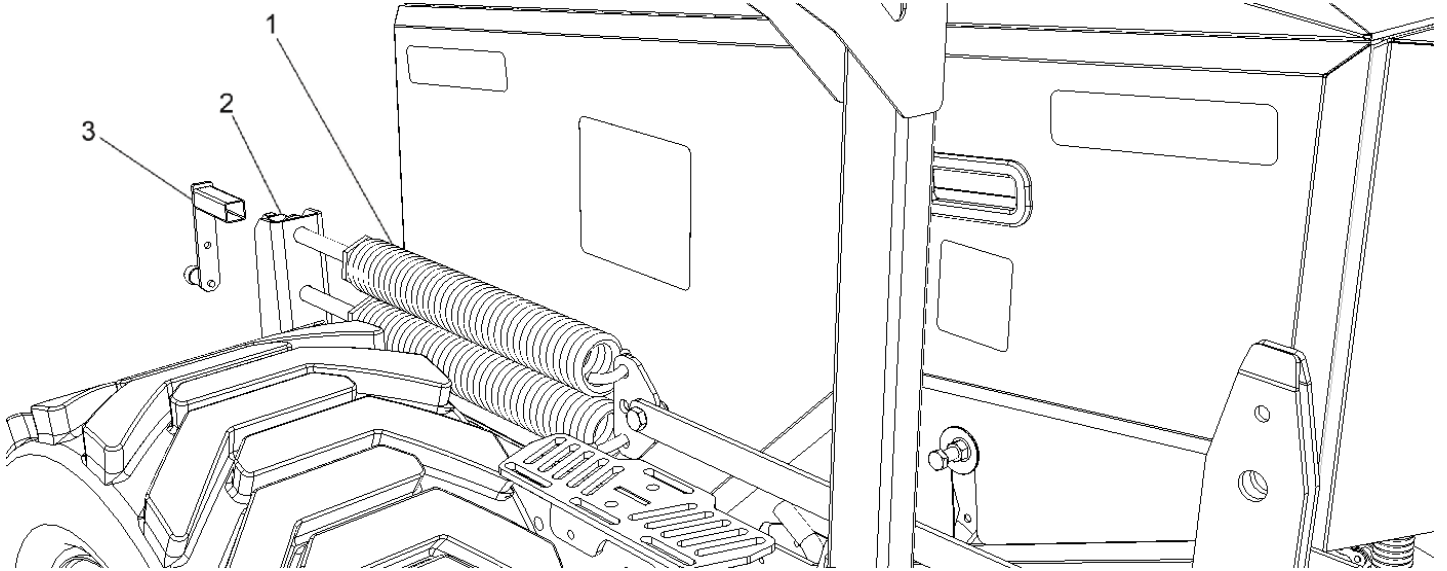

Figure 60 Header lift springs

STEP 2 - FIGURE 61

Select the appropriate spring arm position based on the header that is being installed.

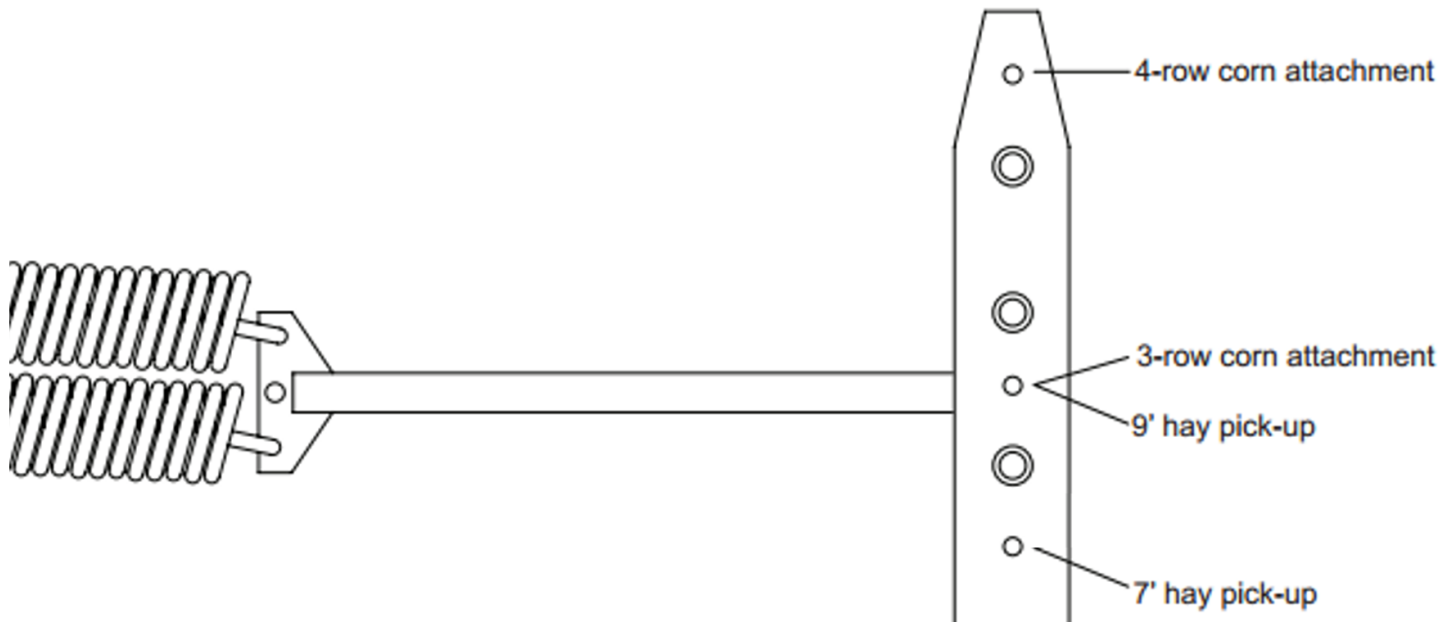

Figure 61 Suspension spring position

STEP 3 - FIGURE 60

Adjust the tension on the springs by evenly tightening the 2 spring tensioning rods (items 2) with the provided square head handle (item 3).

SETUP

HEADER HEIGHT ADJUSTMENT

FIGURE 62

The header height adjustment is achieved through a double acting hydraulic cylinder which is controlled by a switch located on the control box. For windrow pickups, refer to the operator's manual to set the minimal working height with gauge wheels.

NOTE: Push the locking arm in completely in order to unlock the lift cylinder of a header.

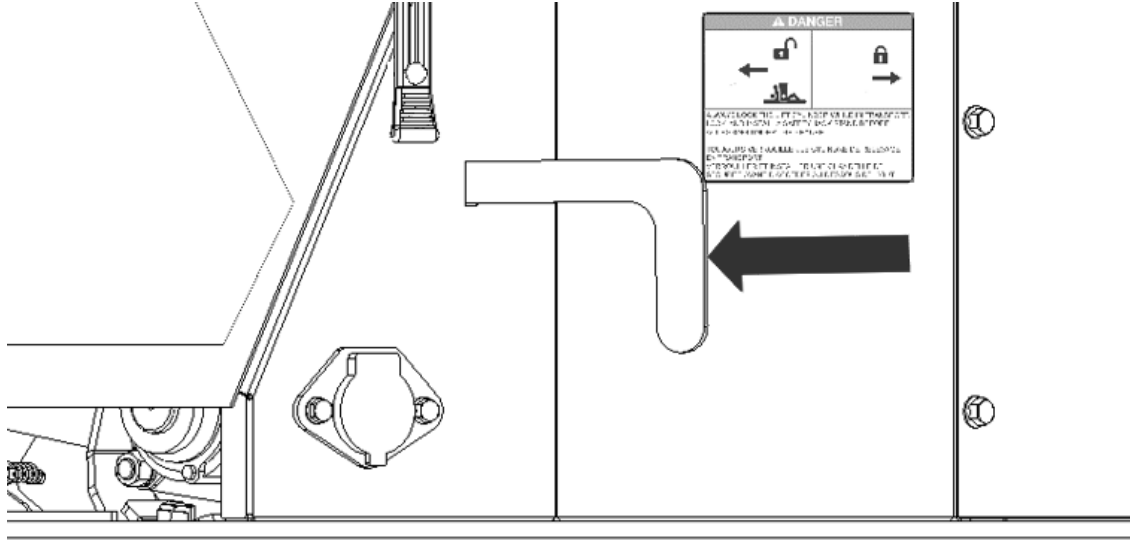

Figure 62 Header lift lock

STARTING UP AND BREAK-IN

Always engage the tractor's power-take-off (PTO) at **low speed** (engine speed at idle) in order to prevent shearing the safety bolt on the transmission line. The harvester has a high inertia and applies a high load on the PTO when starting. Have the tractor PTO clutch calibrated by the tractor dealer in cases of hard starts.

Before going to the field, check that all control box functions are working properly.



WARNING: Make sure all harvester guards and shields are properly in place before starting up the tractor.

When starting up a new harvester, run the machine at mid PTO speed for about 5 minutes in stationary position. Then run at full speed for at least 3 minutes. If no issues or bearing overheating is detected, the harvester is ready for operation.

KNIVES AND SHEAR BAR

If using the Forage Harvester in normal conditions (on a dry field, 5 to 6 hours a day), we recommend grinding the knives once a day. However, if the conditions are excessively muddy or sandy terrain, or with a highly abrasive crop, two daily grindings are recommended. Refer to the KNIFE SHARPENING section on page 53. The cutting head is as important as the shear bar and vice versa when a perfect cut is desired. Proper maintenance and preparation of these two components will result in the following:

- Evenly cut silage
- Less required power
- Less downtime due to mechanical breakdowns

NOTE: The shear bar adjustment must always be done following one of these operations:

- Knife grinding
- Whenever knives must be moved forward
- Knives have been replaced (always change knives in pairs, 180° from each other)
- Shear bar has been replaced or flipped over

SETUP

SHEAR BAR DESIGN

Refer to FIGURE 63 for the following explanations.

- The DION shear bar contains two notches on each side. Specially designed bolts (items 2) sit in these notches and are used only to initially adjust the shear bar parallel to the knife drum.
- The shear bar clearance adjustment bolt (item 3) guides the bar laterally. Tightening it pushes the bar along the notched ramps, moving the bar towards the cutter head knives (see arrows).
- The condition of the shear bar is just as important as the knife sharpness for a high-quality cut. This bar features two cutting faces coated with tungsten. When the edge loses its sharpness on one side, it can be rotated around to use the other edge. Tungsten edges are indicated by item 4.

NOTE: For daily adjustments, after sharpening the knives for example, only the side adjustment bolt (item 3) is used.

- Do NOT use the other 2 bolts (items 2) to continually adjust the shear bar with respect to the cutter head. Improper adjustment of items 2 will cause serious damage to the harvester.
- Ensure the shear bar is always installed with the tungsten edges facing upwards.

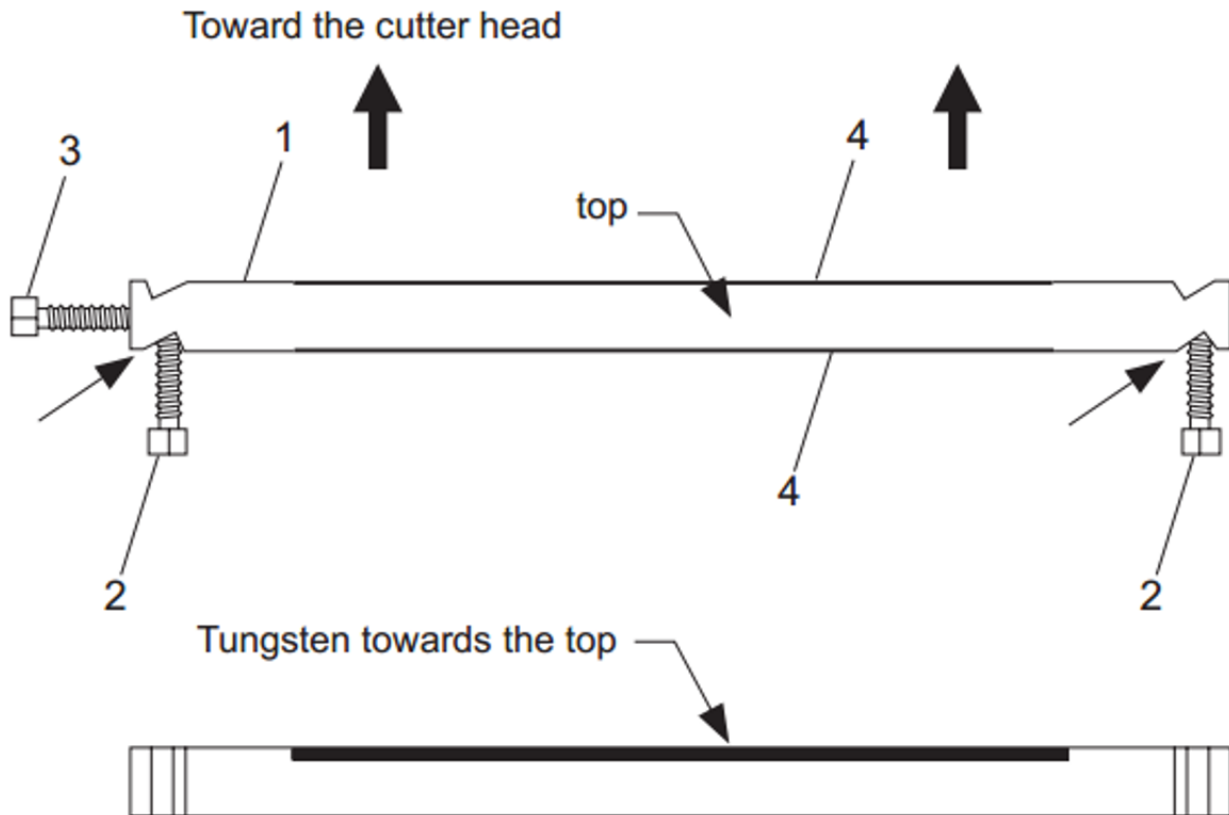

Figure 63 Shear bar adjustment



WARNING: Stop the PTO and turn off the tractor engine before servicing the harvester.

SETUP

KNIFE SHARPENING



DANGER: To prevent serious injury or death, the operator should be the only person to perform the knife grinding operation.



DANGER: The main transmission should be in the NEUTRAL position. Switch off the tractor engine before removing the cover on the cutter head. Make sure the safety brake is engaged.



DANGER: To prevent serious injury or death from rotating knives, stand on the ground with one foot in front of the other to keep your body weight centered when knives are turning. Keep others away.



DANGER : Porter des lunettes de sécurité et ne pas porter de vêtements amples non-ajustés.

NOTE: Refer to the SAFETY RULES section on page 12.

Refer to Figure 64 for the following steps.

1. Open the sharpening door by removing the safety pin and rotating the door rod (item 1) clockwise with a 3/4" wrench or socket. Place the safety pin back in place to keep it safe.
2. Start the tractor engine and engage the PTO. Set the speed to approximately half the operating speed (~600 rpm for « 1000-1000 » models and 750 rpm for « 1000-800 » or « 540-800 » models.
3. Sharpening is achieved by pushing and pulling the stone carriage, at constant speed, along the full width of the cutter head using the handle (item 2). A full stroke should last 2-4 seconds to obtain a smooth grinding along the entire cutting head.
4. To lower the stone, pull the sharpening carriage completely to the end of the stroke, towards the operator. The zinc plated gear needs to make contact with the zinc plated bar in order for the adjustment to function. The stone will lower slightly for every engagement between the gear and bar.
5. Lower the stone sufficiently to produce sparks when passing over the knives. **Never stop mid stroke.**
6. When the sharpening is completed, raise the stone by pushing the carriage to the far end of the stroke and engage the zinc plated gear 8-10 clicks. The stone will raise slightly for every click.
7. Leave the carriage at the far end of its stroke for storage. The lid (item 3) will keep the carriage in place.
8. Remove the safety pin, close back the cutter head cover completely and reinstall the safety pin.

NOTE: When grinding, move the stone evenly over the entire width of the cutter head. This will prevent the knives from burning and also ensure they are sharpened uniformly.



DANGER: Do NOT wear baggy or loose-fitting clothing while sharpening the knives.



WARNING: Eye and ear protection MUST be worn during the sharpening process. Sparks will be generated during this process as well as a high level of noise.

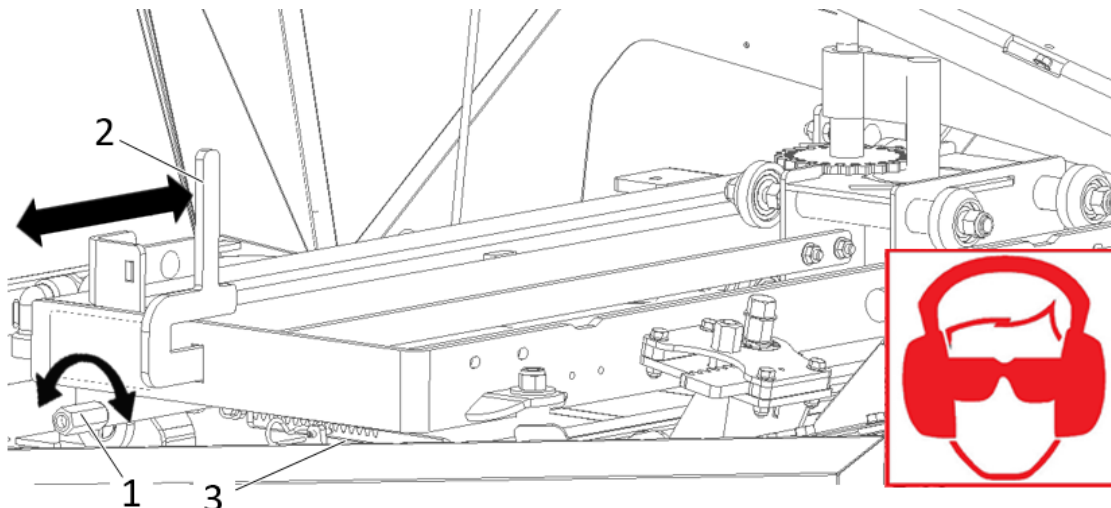

Figure 64 Knife sharpening

SETUP

DAILY SHEAR BAR ADJUSTEMENT

To adjust the shear bar (Figure 65):

1. After knife grinding, with the PTO engaged, lower the tractor engine speed to the minimum.

NOTE: The nearside locking rod (item 1) works directly to tighten or loosen the shear bar, the farside locking rod (item 2) is tightened or loosened through the rack and pinion assembly.



WARNING: Always fully loosen both shear bar locking rods before attempting to adjust clearance. Failure to fully release the shear bar may cause inadvertent bar movement and damage to the knives and the harvester.

2. Loosen the shear bar locking rods (items 1 & 2) **completely**.
3. Using 2 wrenches, loosen the lock nut (item 3) and ensure the clearance adjustment bolt (item 4) does not move. Adjust the bolt (item 4) by **slowly** turning clockwise until the shear bar makes slight audible contact with the rotating knives of the cutting head. Then, loosen the adjustment bolt (item 4) until no audible contact is heard. Then loosen the adjustment bolt (item 4) an additional 1/8 turn to eliminate any possible contact between the cutter head and shear bar. Ideally the knives should be as close to the shear bar as possible without contact.
4. Tighten the shear bar locking rods (item 1 & 2) completely and ensure no contact is being made. If audible contact is heard after tightening both rods completely, loosen both locking rods completely and loosen the adjustment bolt (item 4) another 1/8 turn. Tighten the shear bar locking rods (item 1 & 2) completely and ensure no contact is heard. Repeat if necessary.
5. Using 2 wrenches, tighten the lock nut (item 3) while ensuring the adjustment bolt (item 4) **DOES NOT MOVE**. Ensure there is no contact being made between the cutting head knives and the shear bar.
6. With the tractor turned off and the cutter head fully stopped, the shear bar clearance can be checked from the top door (item 4 - Figure 108 Shear bar replacement). The best quality cut is obtained with minimal clearance and without contact.

NOTE: All the bolts used for the shear bar adjustment are special bolts. Never replace with standard bolts.

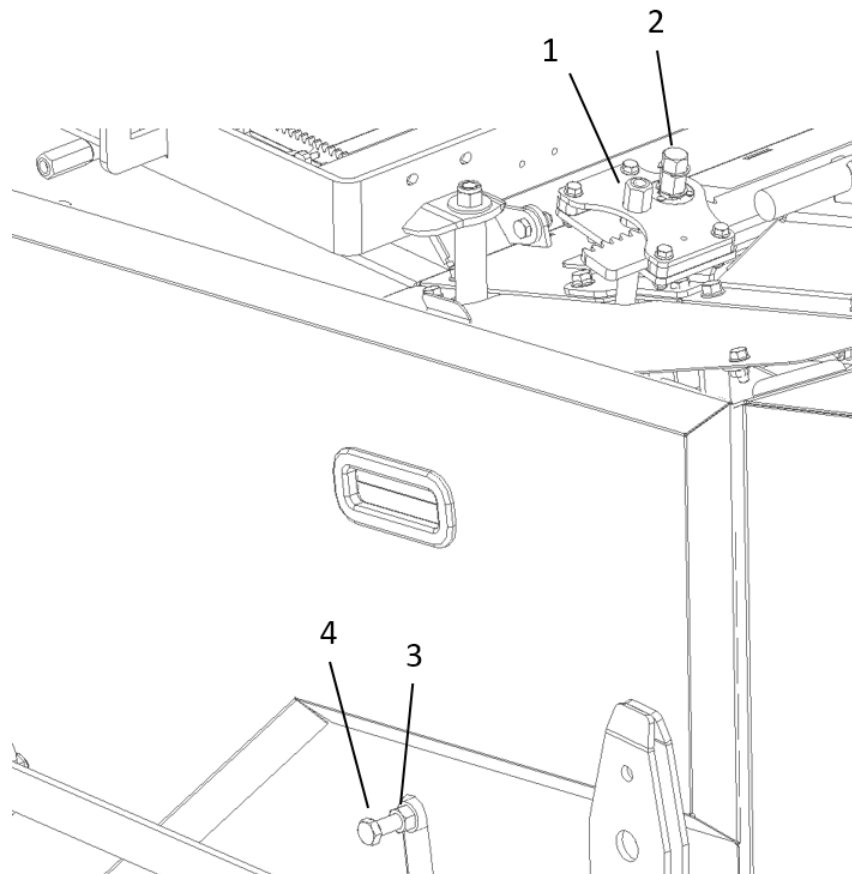

Figure 65 Shear bar adjustment

SETUP

CONTROL BOX FUNCTIONS

FIGURE 66

All harvester functions are controlled through the control box along with the hydraulic system. There is only one model of controller offered and it's equipped with all functions even though the options may not be installed on the harvester (Metal detector or inoculant kit for example).

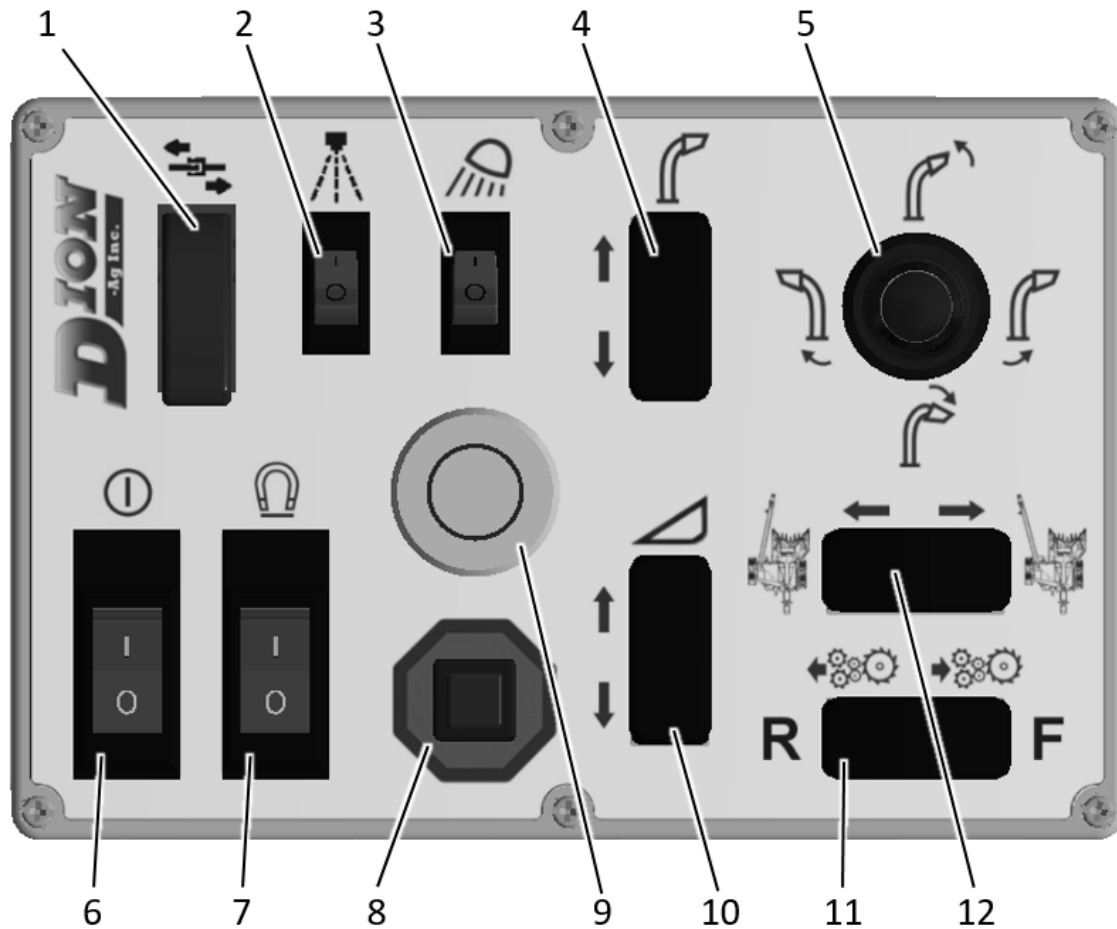

Figure 66 Control Box

1. Trailer quick disconnect with safety cap (OFF/MOMENTARILY ON) – Optional.
2. Liquid/inoculant incorporation system (ON/OFF) – Optional.
3. Spout and work light (ON/OFF) – Optional.
4. Spout height switch (UP/STOP/DOWN).
5. Spout rotation (LEFT/STOP/RIGHT) and deflector (UP/STOP/DOWN) joystick.
6. Main switch with integrated breaker (ON/OFF).
7. Metal detector switch with integrated breaker (ON/OFF) – Optional.
8. Emergency stop button (OFF/MOMENTARILY ON) – Active only with metal detector.
9. Sound and visual alarm – Active only with metal detector.
10. Header height control switch (UP/STOP/DOWN).
11. Transmission shifter switch.
 - a. Fully manual on models without metal detector.
 - b. Automated function with metal detector models, see WITH METAL DETECTOR page WITH METAL DETECTOR.
12. Drawbar position control switch (LEFT/STOP/RIGHT).

SETUP

METAL DETECTOR GENERAL INFORMATION

NOTE: Warranty coverage will not extend to consequential damages.

The metal detector is used for stopping the feed rolls when ferrous material is detected between them. The metal detector antenna is mounted inside the lower front feed roll. When the system is working properly, the following or similar objects will be detected with approximately 95% accuracy:

- Steel fence posts
- Plow points
- Wires
- Hitch pins
- Scrap iron
- Bolts
- Wrenches, tools
- Rake teeth
- Steel pipes
- etc.

The detector will only detect ferrous materials - those containing sufficient iron. It is therefore possible that damages be caused to the machine because of non-detectible objects entering the cutter head. The following is a list of objects (or similar), that will not be detected:

- Stones
- Cement
- Stainless steel
- Aluminium
- Wood
- Tiles

CONTROLLER - FIGURE 71

The metal detector is managed by the electronic controller located on the harvester above the hydraulic valve manifold. It controls the transmission F-N-R (**F**orward-**N**eutral-**R**everse) and the emergency stop system. An indicator light on the controller shows the state of the system.

- Green – Active
- Orange – Feed roll stop, pawl locked or feed roll speed reading error
- Red – Metal detected

The metal detector can be set to three different sensitivity levels for best performance according to specific conditions. It uses a variable threshold that adjusts itself to the harvest conditions (length of cut, vibrations, impacts, etc.) to maximise the detection power. The sensitivity can however be reduced to minimise the risks of false detections and false stops in specific difficult conditions (Heavy wear of the feed rolls for example). The variable threshold system is based on the rotation of the feed rolls and thus requires the feed roll speed sensor to work. In case of a faulty speed sensor, the system remains functional but at a lower sensitivity and reliability fixed threshold.

SETUP



CAUTION: An intensive magnetic field may be present, therefore, people with a pacemaker, hearing aid and/or any other type of devices of this nature, **MUST BE CAREFUL** around the machine. The magnets could affect these types of devices.

IMPORTANT: *Because of the limitations of the system, there is an area at both ends of the lower feed roll where the sensitivity is reduced. As the distance from the lower feed rolls increases, the detector's sensitivity also decreases.*



CAUTION: The metal detector cannot and **MUST** not be expected to be a 100% fool-proof device.

IMPORTANT: *Maximum performance of the metal detector system can be expected only if it is kept in good operating condition and all parts are working correctly. As any electrical system, this unit is subject to malfunction due to normal wear and tear, occasional damage due to rocks and possible misuse. Regular inspection and maintenance are mandatory.*

NOTE: *The metal detector is only sensitive to moving objects. For this reason, it is possible for an object to pass very slowly over the detector "undetected". Keep this in mind when manually checking the system.*

NOTE: *A poorly maintained or adjusted metal detector system causing multiple false detections may damage drive components or cause other failures to the harvester.*

DAILY CHECKS ON THE METAL DETECTOR

It is recommended to check the unit frequently, and at the beginning of each operating day, to ensure proper working condition, using the following procedure:

1. Check wire harnesses, connectors, connections, etc.
2. Check the stop pawl system for free motion. Check the alignment of the NEUTRAL/REVERSE sensors and perform necessary adjustments.
3. Initialize the metal detection system by switching the power and alarm to ON and shifting the transmission to REVERSE. Refer to the INITIALIZING THE METAL DETECTOR section on page INITIALIZING THE METAL DETECTOR.
4. Shift the transmission to FORWARD, stop the PTO and disconnect the PTO shaft from the tractor. Leave the metal detector, tractor engine and hydraulic flow On.



DANGER: Always turn off and disconnect the tractor PTO when performing this test.

5. This test should be performed with a **QUICK forward and backward motion**. Pass a ferrous metal object between the front feed rolls like a straightened metal coat hanger. The solenoid should release the stop pawl onto the ratchet stop cam. The transmission should shift from FORWARD to NEUTRAL automatically
6. If the system is operating properly, the alarm should sound an intermittent and slow "beep" and its indicator light should immediately come ON. (Refer to the legend of alarms on the side of the control box).
7. Initialize the system as described previously to verify if it is operating normally.
8. If the system fails to operate, refer to the Safety Rules section to determine the problem. Make necessary repairs before proceeding any further.



DANGER: To prevent serious injuries or death from rotating feed rolls, do not service or make any adjustments without first:

- a. Stopping the PTO and shutting off the tractor engine.
- b. Making sure that all parts inside the Forage Harvester have stopped rotating.

SETUP

METAL DETECTOR SENSITIVITY AJUSTEMENT

The sensitivity adjustment can be done at any time on the controller itself, located over the hydraulic valve manifold (Figure 71).

FIGURE 67

1. Stop the PTO and wait for all parts to stop rotating before opening the main guard.
2. Turn on the control box and metal detector switches. It is not necessary to have the hydraulic flow ON or the tractor engine running.
3. On the controller, press the configuration button (item 1) for at least 3 seconds until the indicator light blinks quickly several times.
4. Check the indicator light (item 2) flashing pattern to determine the current sensitivity level.
 - a 1 quick flash followed by a pause, repeated – Level 1 (minimum sensitivity).
 - b 2 quick flashes followed by a pause, repeated – Level 2 (average sensitivity).
 - c 3 quick flashes followed by a pause, repeated – Level 3 (maximum sensitivity).
5. To change to the next level of sensitivity, press the configuration button once (item 1). The indicator light will display the new level.
6. To confirm the new level, press and hold the configuration button for at least 3s until the indicator light blinks quickly several times.

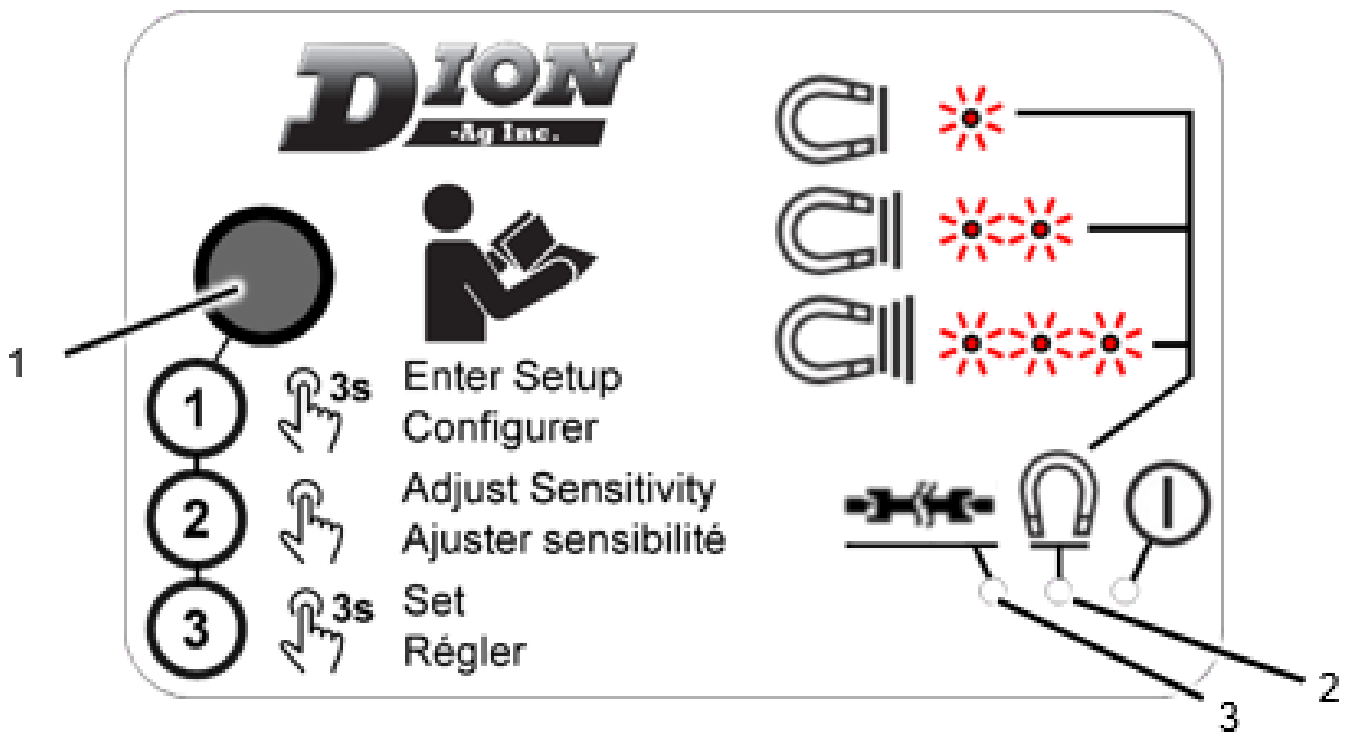

Figure 67: Metal detector sensitivity adjustment

SETUP

DISABLING THE METAL DETECTOR

NOTE: Warranty coverage does not apply to damage or failures caused by the malfunction of the metal detector or its disabling.

When the metal detector fails to operate, it can be useful to by-pass the system in order to complete a full harvest day. However, when doing so, it must be taken into consideration that this is an **emergency and exceptional situation**. If this is the case, follow this procedure and refer to Figure 67 and Figure 68:

1. Switch ON both the breaker & switch (items 3 and 4, Figure 68) on the control box.
2. Press and hold the « R » button to run the feed rolls and header in reverse for a few seconds to allow the stop pawl (item 1, Figure 68) to disengage from the stop cam wheel.
3. Stop the tractor PTO and hydraulic flow, but keep the electrical control box ON.
4. Apply the tractor parking brake.
5. Open the transmission guard and, **as needed**, apply step "A" only OR apply steps "A" and "B":
 - a Press on the controller configuration button (item 1, Figure 67) for at least 8 seconds until the indicator lights (item 2 and 3, Figure 67) blink orange. The controls are now in manual mode.
 - b **If the solenoid is not functional**, apply step "A", then attach the stop pawl spring (item 1, Figure 68) back to the second hook (see the arrow). Make sure the stop pawl clears the ratchet cam wheel.
6. Reactivate the hydraulic flow and resume work.

NOTE: Every time the secondary breaker (item 4) is switch ON, the metal detector is automatically reactivated.

NOTE: When the metal detector is not used, the forage harvester is no longer protected against ferrous materials entering the feed rolls. This must be repaired as soon as possible to prevent damage to the machine.



WARNING: Remember to hook the stop pawl spring (item 1) back to its original location before using the metal detector. The spring should be set in reverse position **ONLY** if the solenoid is inoperative.

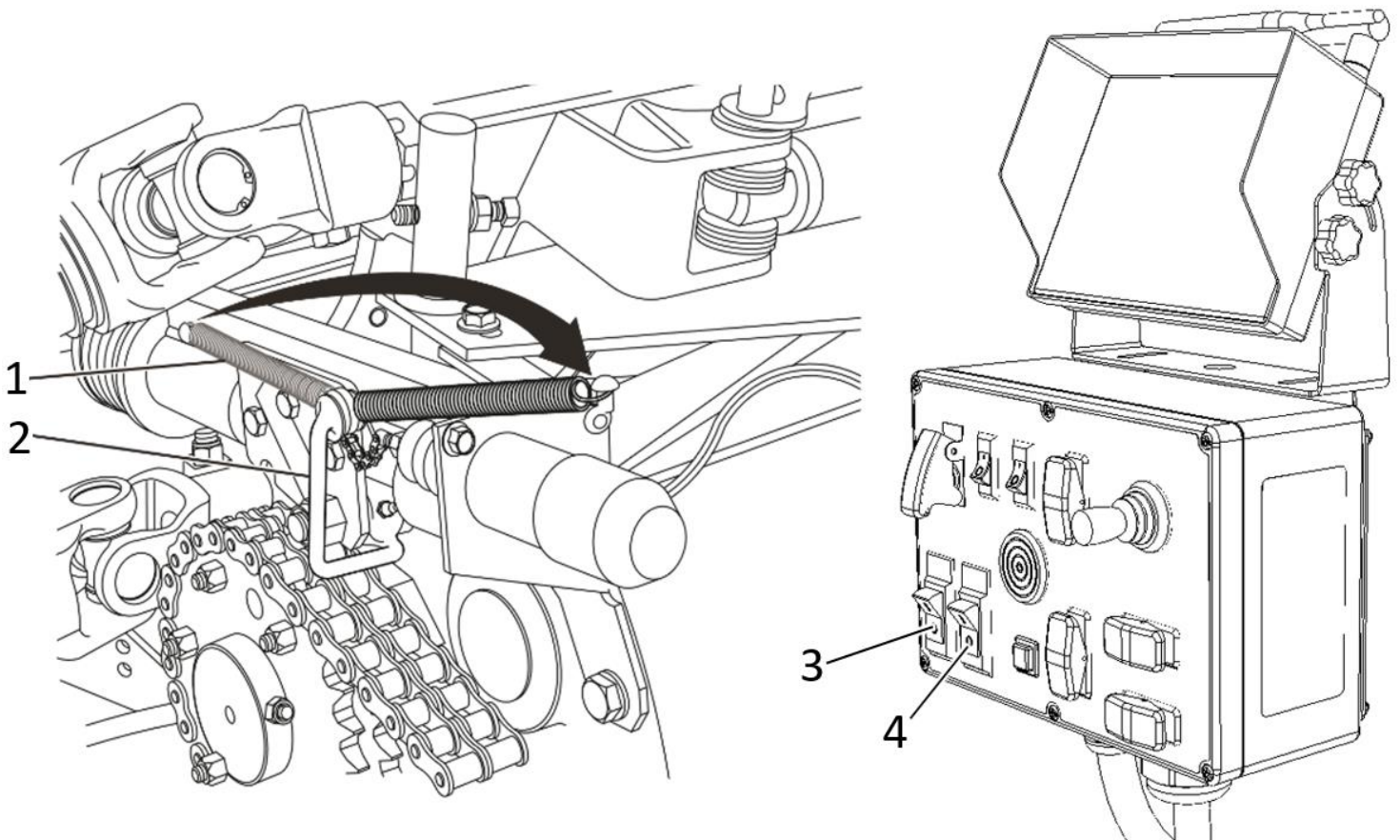

Figure 68 Disabling the metal detector

SETUP

DRIVE FAILURE DETECTOR

As part of the controls included in the metal detector controller, a speed sensor measures the speed of the cutter head (Figure 69) and one reads the speed of the top feed rolls (Figure 70), to check for their relative speed.

CUTTER HEAD SPEED SENSOR

This sensor reads the speed directly on the cutter head shaft behind the pulley. If the shear bolt on the cutter head shaft breaks (or optional friction clutch slips), its speed will quickly decrease with respect to the feed roll speed and the controller will detect it. Maintain a gap of less than 1mm (0.040") between the sensor tip (item 2) and the encoding wheel (item 1) without making contact.

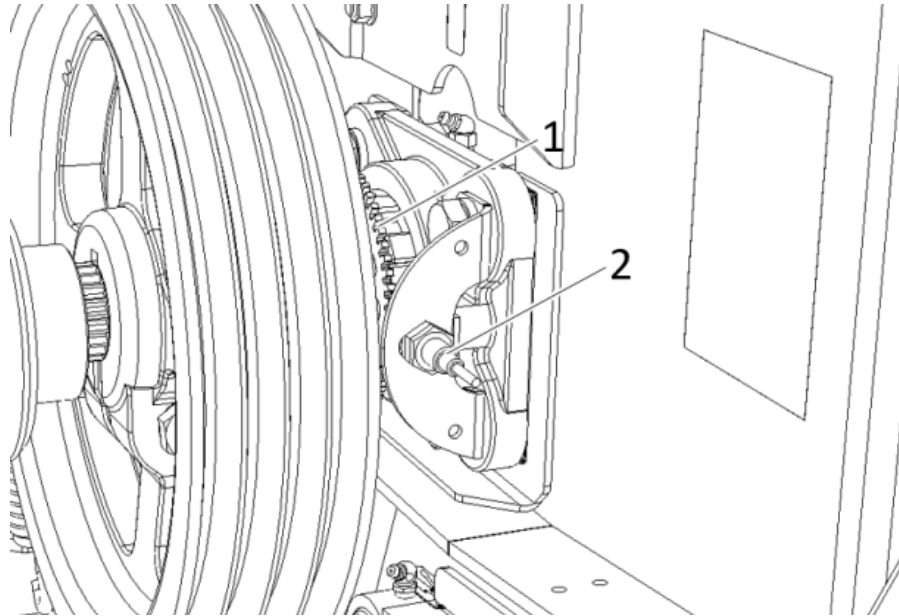

Figure 69 Cutter head speed sensor

FEED ROLL SPEED SENSOR

This sensor reads the speed of the top feed roll shaft on the F-N-R gearbox and can be used to detect inconsistencies between the shifter position and feed roll speed (Item 1, Figure 70). Maintain a gap of less than 1mm between the tip of the sensor and the encoding wheel.

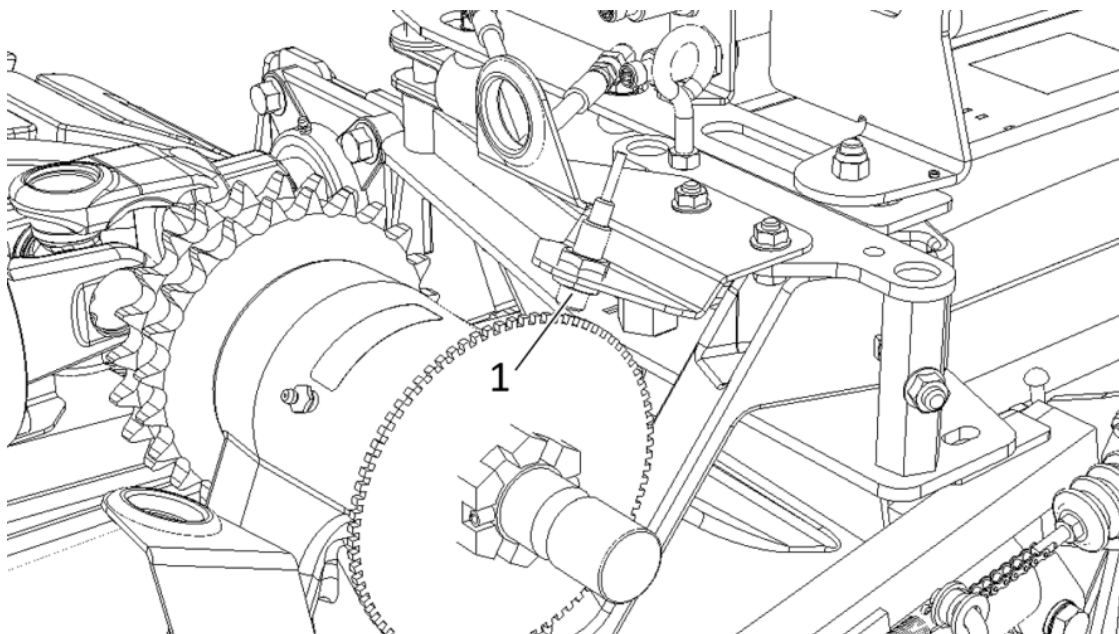

Figure 70 Feed roll speed sensor

SETUP

The shear bolt (drive failure) detector is run on the harvester controller. The indicator light (item 3 on FIGURE 71) shows the state of the detector.

- Green – Active.
- Orange – Deactivated.
- Red – Shear bolt breakage or slip clutch slippage detected.

TYPE OF FAILURE OR DETECTABLE ERRORS

- Cutter head drive shaft shear bolt is broken.
- Feed rolls are still turning but not the cutter head.
- Cutter head friction clutch is slipping (for models equipped with that option).
- Feed roll speed error: The transmission is in "FORWARD" position and the cutter head is turning, but the feed rolls are not turning.

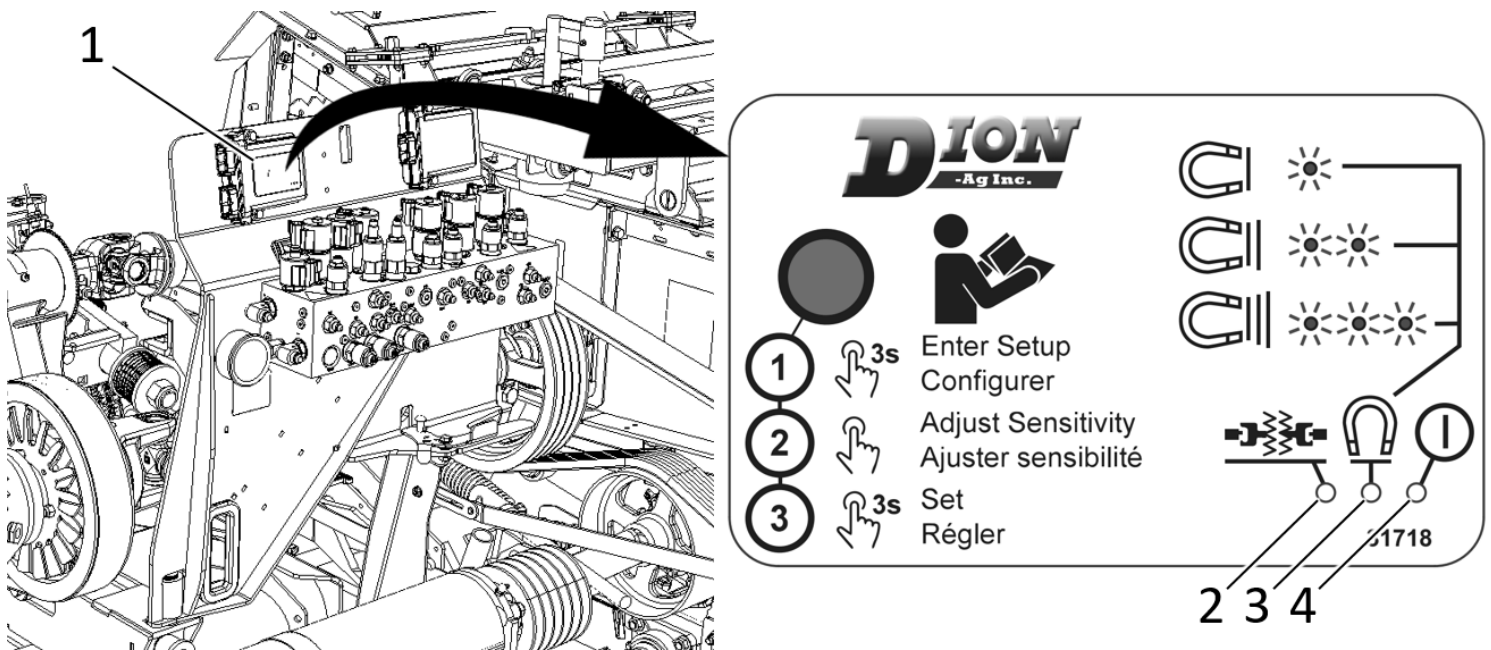

Figure 71 : Controller and indicator lights

DISABLING THE DRIVE FAILURE DETECTOR

In the cases where a speed sensor has failed or another reason which requires disabling the drive failure detector, proceed as described in Figure 68:

1. Turn off the main control box switch.
2. Press and hold the forward « F » button while turning the control box back ON. After a few seconds, the alarm will beep indicating the system is deactivated.

The controller indicator light, on the harvester, will be illuminated in orange when deactivated. The metal detector remains active.

NOTE: Every time the control box is turned ON, the drive failure detector is reactivated automatically.

SETUP

LIQUID INCORPORATION SYSTEM

The system can be used to add preservative to the silage or to lubricate the crop channel and spout to maintain the throwing capacity of the harvester in gummy conditions. The harvester is pre-wired for a liquid/inoculant incorporation system. The application can be done at two locations: by default, over the accelerator chamber (Item 1, Figure 72) or on the windrow pick-up.

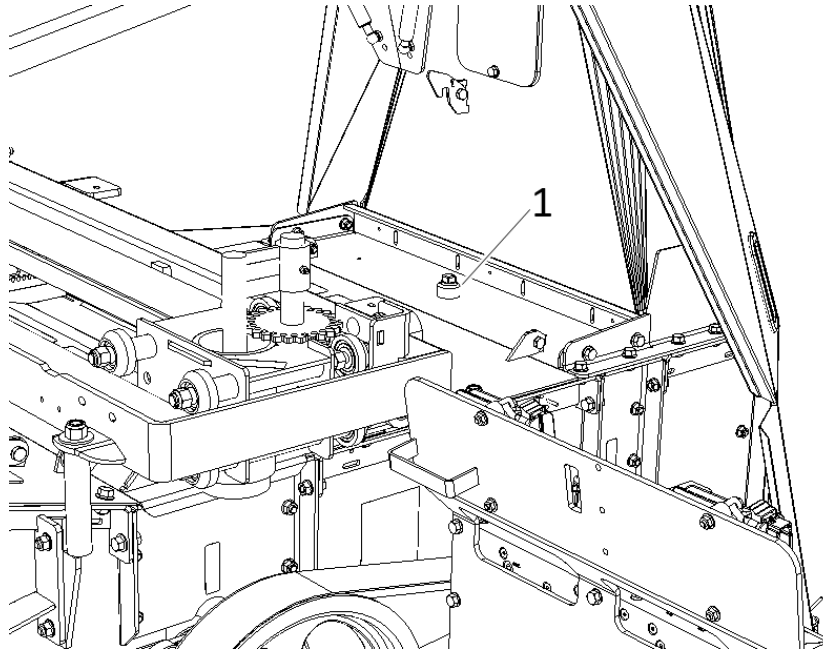

Figure 72 Default location of the liquid incorporation nozzle

The flow is regulated by adjusting the pressure at the pump. It must be adjusted to match the average throughput with to obtain constant application rate. See Figure 66 for the control switch location.

PRESSURE ADJUSTMENT

To adjust the pressure:

1. Refer to *Table 2: Flow vs Pressure of the XR TEEJET XR8004 nozzle* to select the right pressure to obtain the correct amount of liquid applied to the crop.
2. Adjust the pressure by modifying the pressure regulator setting. Turn the handle (item 1), then lock with the ring (item 2).

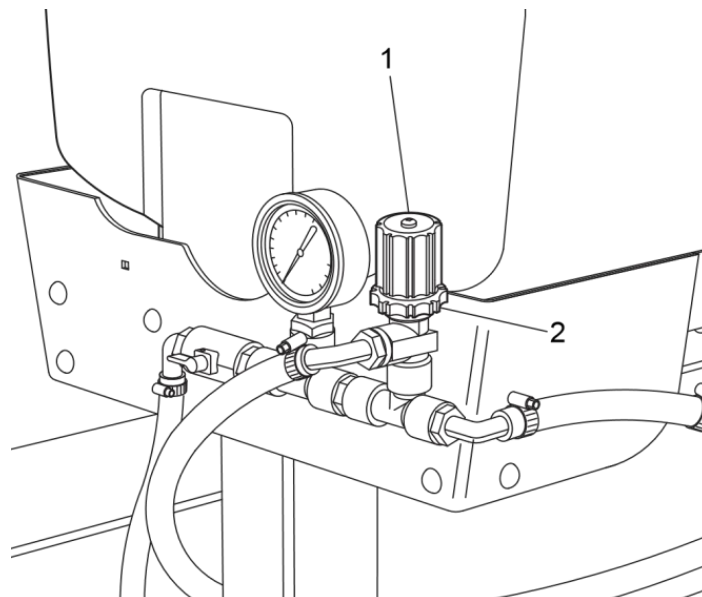

Figure 73 System pressure adjustment

SETUP

XR TEEJET XR8004 NOZZLE				
PRESSURE		FLOW		
Bar	psi	l/min	gal(US)/min	gal(IMP)/min
1	15	0.91	0.24	0.2
1.5	20	1.12	0.28	0.23
2	30	1.29	0.35	0.29
3	40	1.58	0.4	0.33
4	60	1.82	0.49	0.4

Table 2: Flow vs Pressure of the XR TEEJET XR8004 nozzle

NOTE: The electrical connection must be made through a load-protected circuit. Use the harness provided in the liquid incorporation kit which includes an activation relay. This harness and the standard harvester wiring can be used for other Tier liquid incorporation systems as long as it drives through the DION-Ag relay harness. These parts are available through DION-Ag parts department: Relay Cable (part# 30896) and Extension Cable (#31511).

FLOW CALIBRATION PROCEDURE

FIGURE 74

The system must be calibrated to ensure the correct dosage of liquid/inoculant is applied to the crop.

1. Fill the reservoir with clean water, 10-15l (3-4gal.) is sufficient.
2. Adjust the system pressure to the pressure corresponding to the desired flow.
3. Purge all air from the system by allowing the water to exit the nozzle until the flow is uninterrupted.
4. Inside the accelerator, place an empty bucket (see arrow) under the nozzle (item 2) to collect the water.
5. Collect the water dispensed by the system by running the system for 1 minute.
6. Measure the water volume collected during 1 minute.
7. Make the necessary adjustments to the system pressure until the desired flow is obtained.

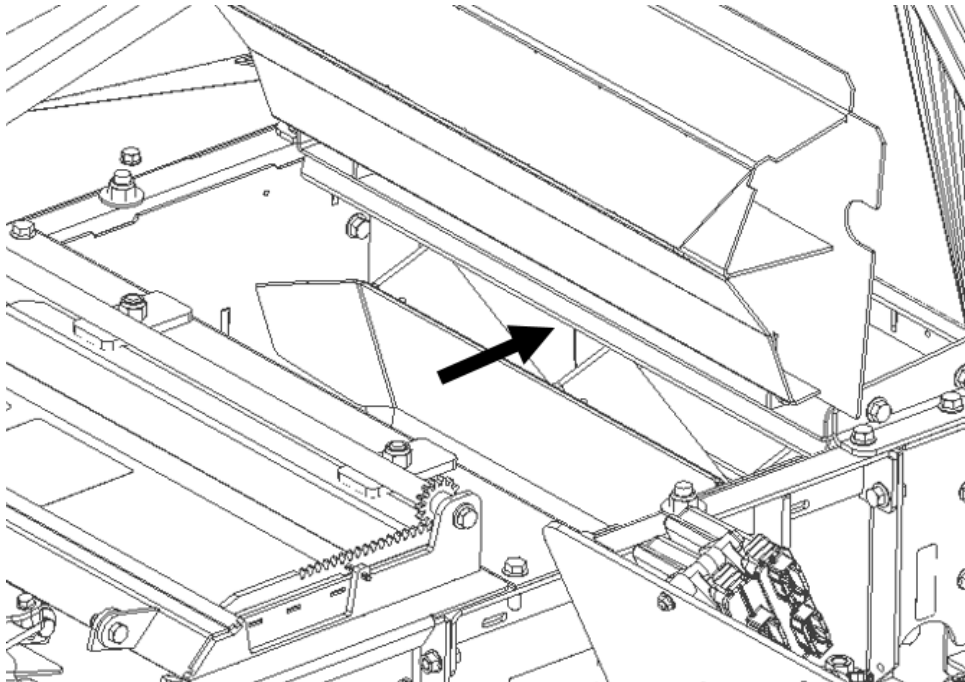

Figure 74 Flow calibration

SETUP

TRANSPORT LIGHTS

FIGURE 75

The transport lights on the right-hand side can be raised to reduce the harvester overall width when storing the machine or circulating in narrow spaces. To raise, remove the pin (item 1 configuration 2), then raise the light assembly and reinstall the locking pin (item 1 configuration 3).

The lights can also be adjusted to two different positions, on both sides. Generally, regulations require that the extremity of the light be less than 40cm (16in) from the outermost edge of the harvester, including the header, in transport position. Check with your local authorities for the applicable requirements.

- On the left-hand side, unbolt the support and move to the next set of holes.
- On the right-hand side, an extension bar is provided with the light package to obtain the extended position that may be required depending on the header width. Make sure the red lights and reflectors are located on the back side.

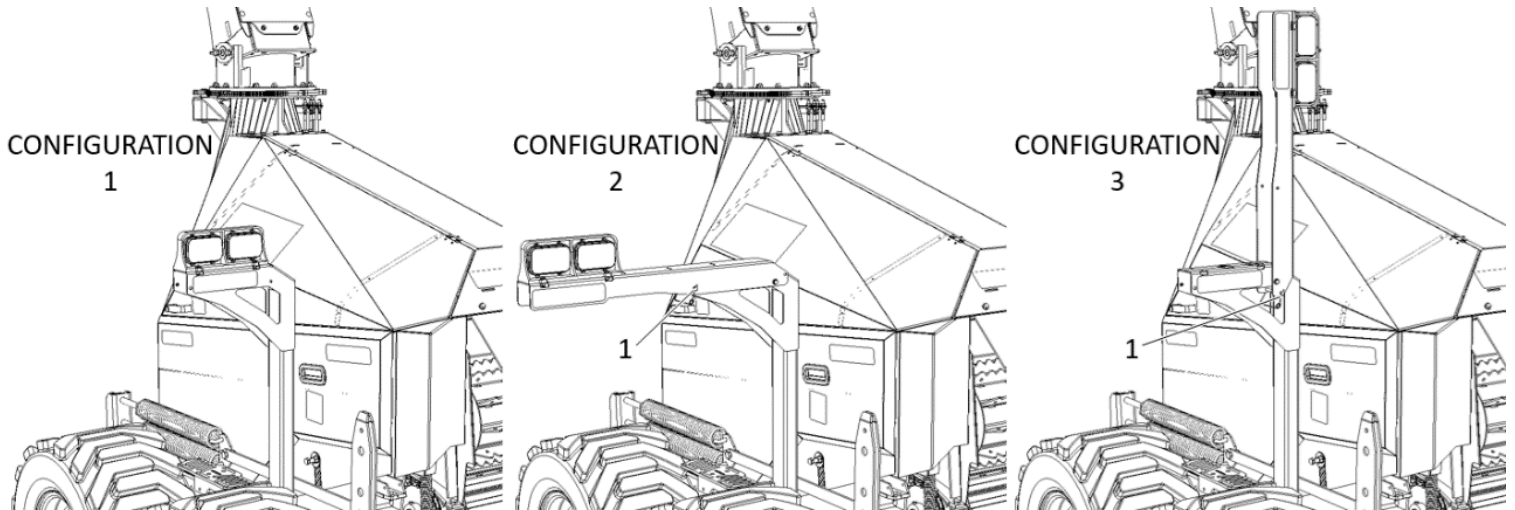

Figure 75 Transport light configuration

SETUP

SET TRACK WIDTH

FIGURE 76

The right-hand side of the machine is equipped with a 3-hole, adjustable axle which purpose is to better distribute the weight or track with crop rows. The hole closest to the wheels is #1 and furthest from the wheels is #3.

Hole #1 and #2 - Transport and operating position

Hole #3 - Position is reserved for maintenance and for installing or removing the processor roll.

NOTE: Make sure the 3 wear plates on the axle tube face upwards.

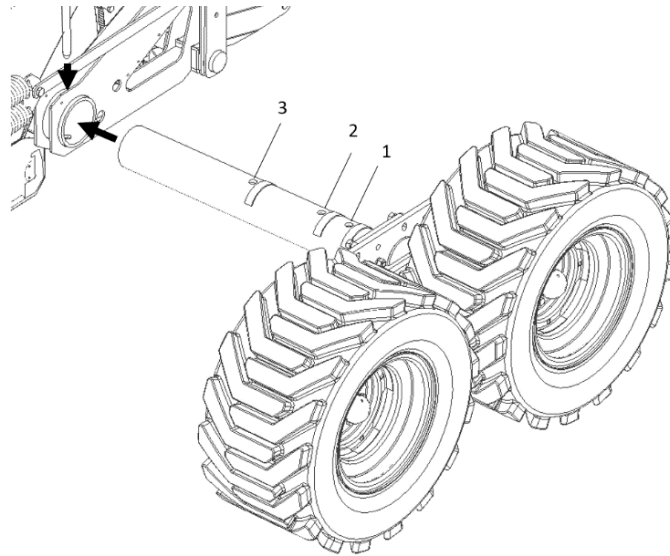

Figure 76 Track width adjustment

GROUND CLEARANCE

It is possible to adjust the height of the forage harvester according to the ground conditions and the height of the tractor drawbar.

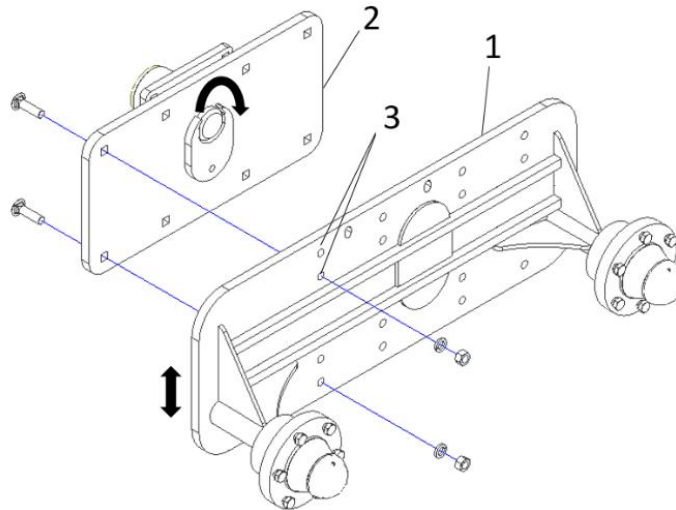

Figure 77 Axle height adjustment

Three positions are available depending on the mounting of the tandem axles. The intermediate position is recommended for most applications.

To raise or lower the forage harvester:

1. Unbolt the tandem plates (item 1 & 2). One side at a time.
2. Move or rotate the internal plate to achieve the desired height.
3. Re-bolt in place ensuring both sides are in the identical hole locations.

OPERATION

OPERATION PRACTICAL ADVICE



WARNING: A forage harvester can pose a severe health risk if not used properly. Make sure the safety rules are followed by everyone operating the machine or in its vicinity. Refer to page SAFETY RULES the SAFETY RULES.

NOTE: *With safety in mind, we suggest to perform a general inspection and adjustment verification before starting the harvester.*

HARVESTER DRAW BAR POSITION

Maintain the draw bar (item 1) as straight as possible (as close to 90° as possible) when operating in the field to reduce the drive shaft angles. This will increase the life of the universal joints and reduce vibrations. Also, with a straighter draw bar position, trailers being pulled behind the harvester will track better.

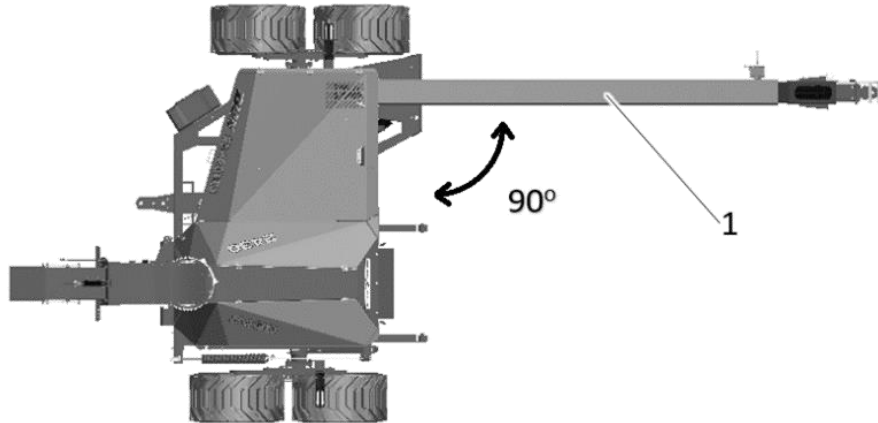

Figure 78 Harvester drawbar

STOPPING THE MACHINE

It is essential to familiarize yourself with the controls and safety rules. It is essential to know how to stop the machine before starting it. Refer to page 69, section STOPPING THE HARVESTER.

FIELD WORK

To set the harvester in harvesting mode:

1. Release the spout lock by pushing on the lock handle (item 1) to allow ring gear movement.

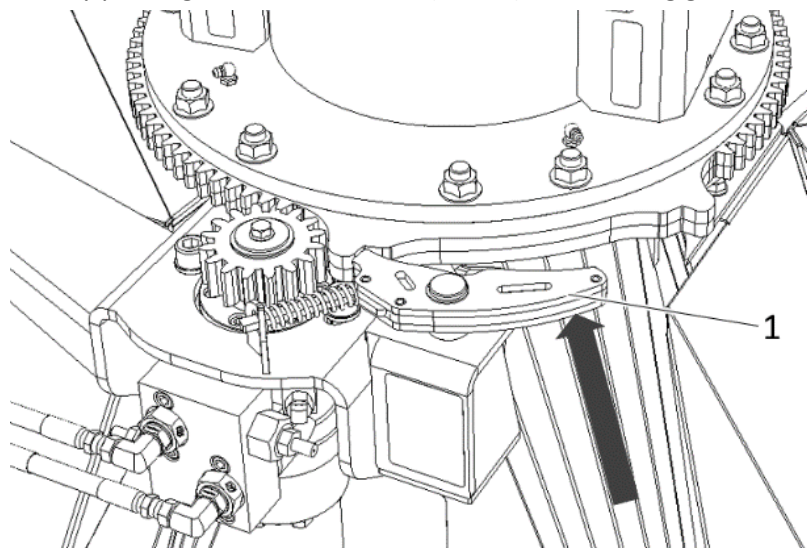

Figure 79 Spout unlock

OPERATION

2. Push the handle **in** towards the harvester to unlock the header lift cylinder (Figure 80).

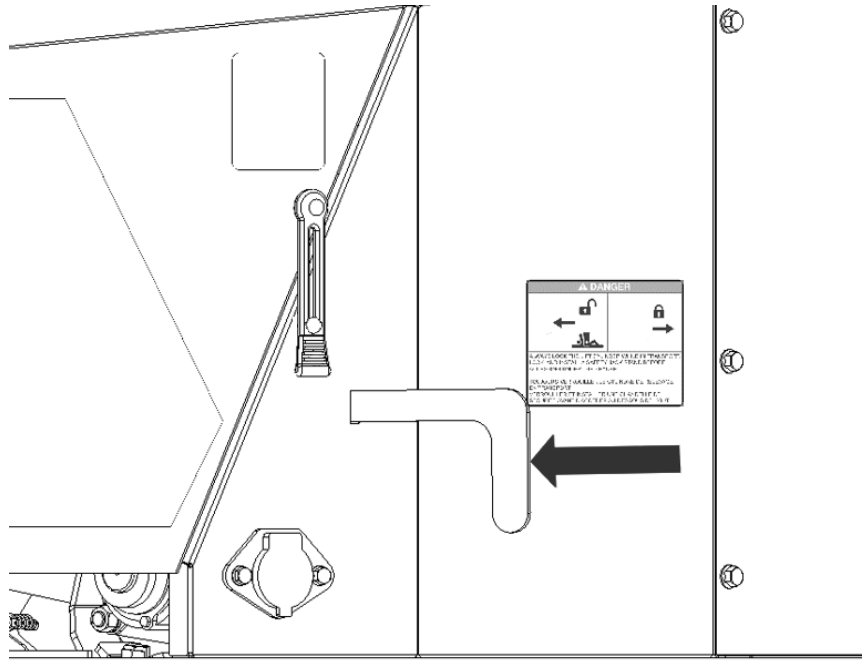

Figure 80 Unlocking the header lift cylinder

3. Unlock the drawbar by removing the transport locking pin (item 1). Store the pin in the toolbox.

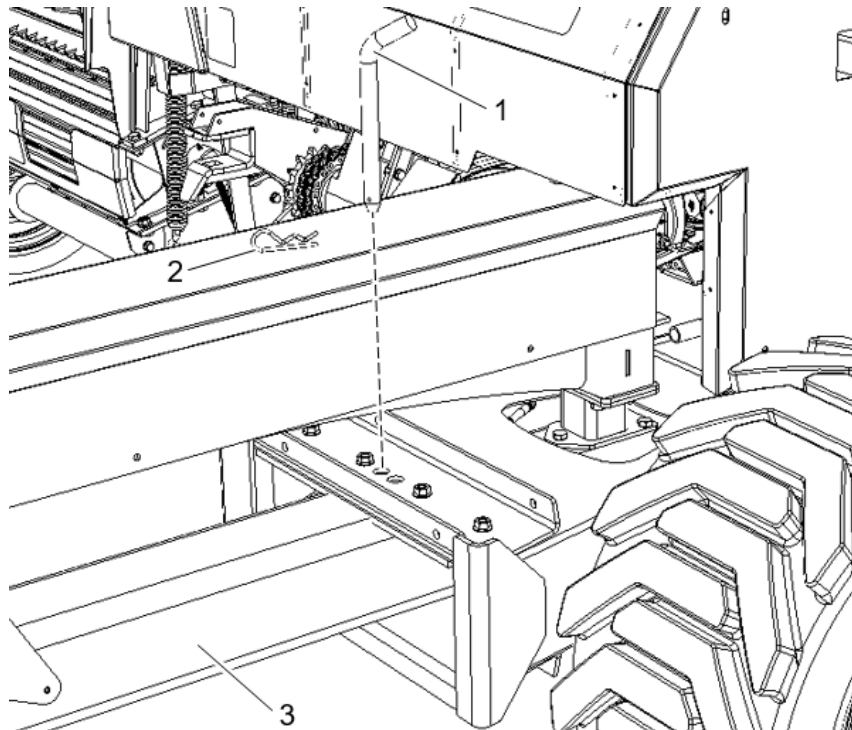

Figure 81 Unlocking the drawbar

4. Activate the hydraulic valve of the tractor connected to the harvester. Make sure the flow is limited to less than 11 l/min (3 GPM) and the back pressure on the valve manifold gauge remains below 50 psi.
5. Turn on the control box – Item 1, Figure 83.
6. Initialize the metal detector (if equipped) – See following section.

The harvester is now operational as soon as the PTO is activated on the harvester.

OPERATION

F-N-R TRANSMISSION SHIFTING

FIGURE 83

NOTE: The tractor SCV must be set in continuous mode to shift the transmission.

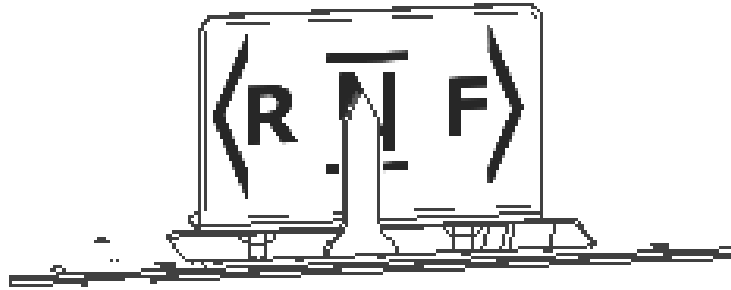

Figure 82 Shifter indicator

WITHOUT METAL DETECTOR, OR DEACTIVATED

In this configuration, the transmission control is fully manual.

REVERSE: Press and hold 'R' on the shifter switch (item 5) to move the shifter to the reverse position. Make sure the button is pressed until the shifter has moved to the end of its stroke. Continue to hold 'R' for as long as needed.

FORWARD: Press and hold 'F' on the shifter switch (item 5) to move the shifter to the forward position. Make sure the button is pressed until the shifter has moved to the end of its stroke.

NEUTRAL: When in reverse, press and hold 'F' (item 5) to move from REVERSE towards NEUTRAL. Stop mid-way (NEUTRAL) when the indicator arm is centered with the 'N' on the indicator.

NEUTRAL: When in forward, press and hold 'R' (item 5) to move from FORWARD towards NEUTRAL. Stop mid-way (NEUTRAL) when the indicator arm is centered with the 'N' on the indicator.

WITH METAL DETECTOR

For any harvester model equipped with the *FerroDtec* metal detector system, the transmission will operate in a semi-automatic mode. The main switch and detector switch (Items 1 and 2) on the control box must be ON, as well as the hydraulic system.

REVERSE: From the NEUTRAL position, press and hold 'R' on the shifter switch until the shifter has moved to the end of its stroke in order to engage the transmission in reverse. Continue to hold 'R' for as long as needed. Releasing 'R' will shift back to NEUTRAL automatically.

FORWARD: From the NEUTRAL position, press 'F' once (hold for a fraction of a second). The transmission will engage FORWARD automatically.

NEUTRAL: From the FORWARD position, press 'R' once (hold for a fraction of a second). The transmission will return to NEUTRAL automatically.

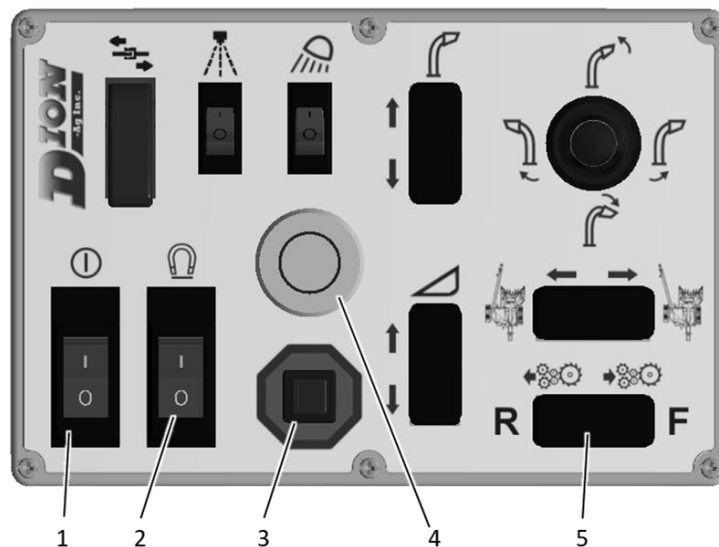

Figure 83 Control box

OPERATION

INITIALIZING THE METAL DETECTOR

For models equipped with the **FerroDtec** metal detector system, referring to FIGURE 83, follow these instructions to initialize the system. This must be done at the system start-up:

1. Start the tractor engine and activate the SVC, connected to the harvester, in continuous flow mode.
2. Turn ON the main switch and metal detector switch (items 1 and 2). The LED light and buzzer alarm will emit continuously. If the transmission is in FORWARD or REVERSE, it will automatically move to the NEUTRAL position. The shifter will remain in place if already in NEUTRAL.
3. Validate that the transmission is in NEUTRAL.
4. Engage the PTO at this time, or after the initialisation.
5. Shift the transmission to REVERSE. The alarm will turn off, confirming the initialization.
6. Shift the transmission to FORWARD, the harvester is now ready to harvest. If the alarm continues to emit, refer to the DIAGNOSTICS & TROUBLESHOOTING section of this manual.

IMPORTANT: To initialize the system, the shifter must first be in NEUTRAL and then shift to REVERSE.

IMPORTANT: If the tractor engine is turn off for several minutes, turn off the control box main switch to avoid discharging the tractor batteries. Following every shut off, the detector must be reinitialized.

NOTE: Refer to the DIAGNOSTICS & TROUBLESHOOTING *Erreur ! Source du renvoi introuvable.* **section to locate and solve potential issues.**

STARTING UP

Before harvesting a crop through the forage harvester, the power-takeoff (PTO) should run at the required speed e.g. 540 or 1000 rpm, as the case may be. Allowing the harvester to reach operating speed will prevent any material accumulation (clogging), breaking of the shear bolts or slipping of the friction clutch.

The specified rotation speed (540 or 1000 rpm) should be maintained throughout the harvesting period. However, it is recommended to choose an adequate FORWARD ground speed to maintain a constant load on the harvester for best performance.

IMPORTANT: Following the first two hours of field operation, the operator should check the entire machine to make sure all bolts are securely tightened and check for any oil leaks. Also, make sure all wheel bolts are properly tightened.

NOTE: Adequately sharpened knives and a correctly adjusted shear bar will increase the efficiency of the forage harvester and the cut quality.

STOPPING THE HARVESTER

Follow these instructions to properly stop the harvester:

1. Set the transmission to NEUTRAL.
2. Disengage the PTO and stop the SCV flow.
3. Engage the tractor park brake and block the harvester wheels.
4. Turn off the control box and tractor engine.

IMPORTANT: If the tractor engine is turn off for several minutes, turn off the control box main switch to avoid discharging the tractor batteries.

OPERATION

METAL DETECTION PROCEDURE

When a ferrous material is detected, the alarm is activated and the feed rolls and header are stopped within milliseconds. The transmission will also shift to NEUTRAL automatically. The transmission overload clutch will momentarily emit a loud clacking while the transmission shifts to Neutral. In this case:

1. An intermittent alarm resounds (refer to the legend on the side of the control box). Stop the tractor and reduce the engine speed.
2. Make sure the transmission is in NEUTRAL.
3. Stop the PTO and the tractor.
4. Put on the park brakes and block the harvester wheels.
5. Remove the key from the tractor and carry them with you.
6. Wait until the rotating components have completely stopped.
7. Manually remove the plants from the header (the metal that caused the alarm is not in this section of the machine).
8. Manually rotate the feed rolls to expel the crop caught between them. The metal part will be found in this section. It may be difficult to locate the smaller metal part in the crop, or the part may have fallen to the ground or between the bottom feed rolls.
9. INITIALIZING THE METAL DETECTOR (see page INITIALIZING THE METAL DETECTOR) and resume harvesting.

PROCESSOR ROLL PRESSURE AND SPACING

The operator can select the silage condition by varying the pressure and clearance of the upper processor roll (item 1).

Refer to FIGURE 84.

1. Adjust the pressure using the square headed handle (item 3).
2. Turn the left-hand spring threaded rod (item 4) until a 1.5 mm (1/16") space is obtained between the spring coils.
3. Adjust the upper roll gap by the elastic stop nuts (item 5, on both sides) on both of the vertical adjusting rods (item 6). Ensure the tension applied to the rods is equal on both sides.
4. Adjust the nuts equally to achieve the same indicator limit (Items 7 & 10).

NOTE: The adjustment is done mainly by varying the processor roll clearance.

NOTE: A linkage system maintains the rolls parallel and a uniform clearance over the width of the rollers.

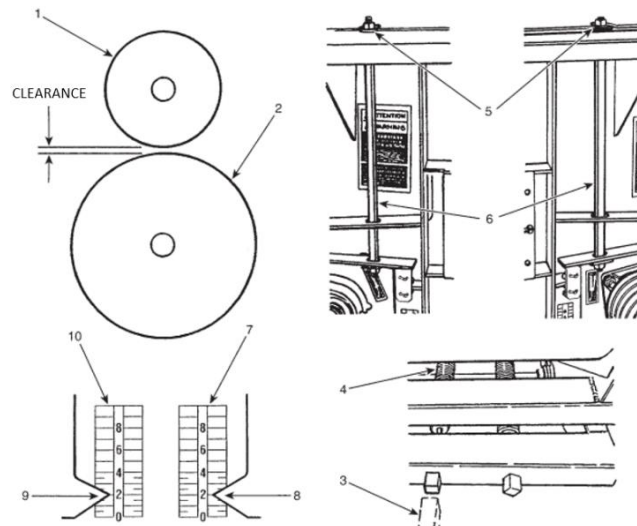

Figure 84 Processor roll clearance and pressure

OPERATION

PROCESSOR ROLL CLEARANCE ADJUSTMENT PROCEDURE

To facilitate the processor roll adjustment and obtain the desired silage quality (Figure 85):

1. Adjust the roll spacing to position 2 shown on the decal (item 1). Each level (2, 4, 6 & 8) represents a 3mm (1/8in) additional clearance. Processor roll clearance at Level 2 = 6mm (1/4in) gap between the rolls.
2. Harvest over 60-90 meters (a few hundred feet) and verify the silage quality.
3. Depending on the level of processing you find, increase or reduce the clearance by half a mark (1.5mm) at a time.
4. Repeat steps 2 and 3 until the desired silage quality is obtained.

NOTE: A larger processor roll clearance requires less tractor power. For the best efficiency, maintain the largest gap possible that provides the desired processing or corn cracking.

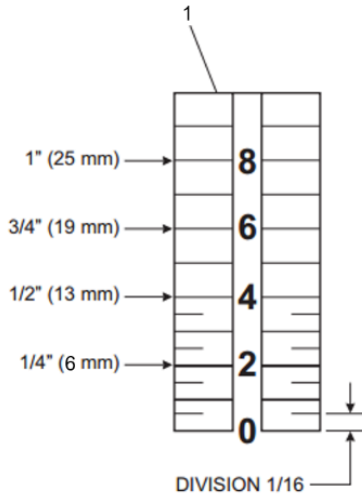

Figure 85 Processor roll clearance decal

HEADER OR FEED ROLL OVERLOAD

In the event of plugging or jamming of the header or the feed rolls, the overload protection clutch on the F-R transmission (FIGURE 86, item 1) will slip and emit a warning sound. Similarly, a blockage can trigger a slippage of the header overload clutch (friction or radial ball clutch) and cut the power transmission.

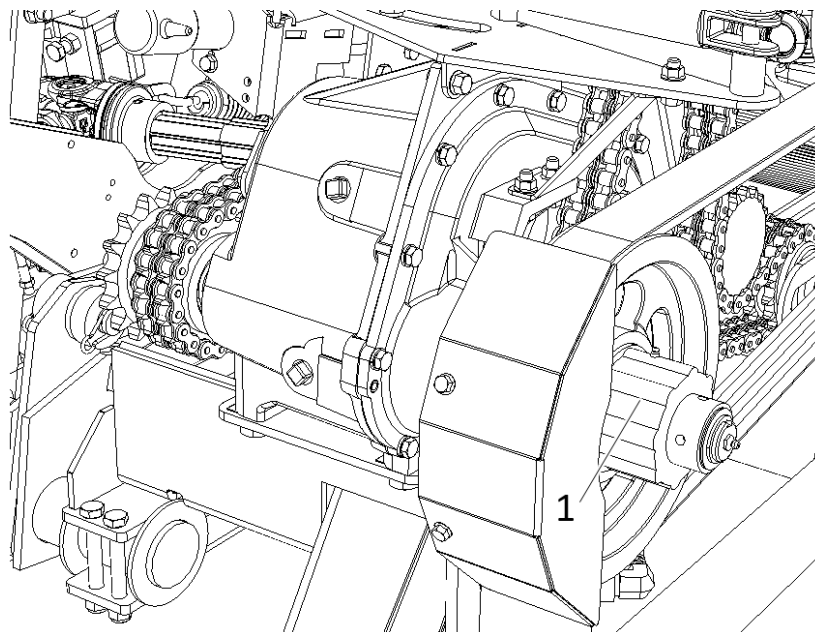

Figure 86 F-N-R transmission overload clutch

OPERATION

When an overload happens:

1. Press the Emergency Stop button (FIGURE 83, item 3) or quickly shift the transmission to NEUTRAL to avoid clutch overheating.
2. In case of minor blockages, reduce the PTO rpm to the minimum, then shift the transmission to REVERSE for as long as necessary to unplug the jammed silage.
3. If this does not clear the blockage, disengage the PTO.
4. Engage the parking brake and block the equipment wheels.
5. Switch off the tractor engine.
6. Listen and wait for all rotating parts to come to a complete stop.
7. Clean the machine and remove the excess material which has accumulated.
8. Start the machine at minimum RPM and use REVERSE to free the feed rolls from accumulated crop.
9. Shift the transmission to FORWARD and resume harvesting.

NOTE: It is not necessary to initialize the harvester after a blockage since the controller has not been turned off. If the controller was turned off, see INITIALIZING THE METAL DETECTOR on page INITIALIZING THE METAL DETECTOR for the procedure.

SHEAR BOLT FAILURE

The cutter head drive shaft is protected by a 12 mm X 55 mm, grade 8.8 safety bolt (item 1, Figure 87).

The universal joint flanges are equipped with a grease Zerk (item 2, FIGURE 84) to prevent seizing of the shaft to the flange if the shear bolt breaks. When the cutter head shear bolt fails, the feed rolls keep turning and the *FerroDtec* controller will automatically make an emergency stop (for models equipped with the detector).

An intermittent failure alarm (4/5s ON – 1/5s OFF) is activated and the transmission shifts back to NEUTRAL to avoid a feed roll or header blockage.

Before resuming harvesting:

1. Shift the transmission to REVERSE to empty the feed roll throat and shift back to NEUTRAL.
2. Stop the PTO and turn off the tractor, engage the parking brake and block the equipment wheels.
3. Wait for all rotating parts to come to a complete stop.
4. Replace the broken shear bolt.
5. Clear the feed rolls or header if any crop remains.

NOTE: Clean the processor rolls if needed (see on page HEADER OR FEED ROLL OVERLOAD).

6. Start the tractor, engage the PTO at low speed with the harvester in NEUTRAL, and accelerate the engine speed quickly to clear the harvester.
7. Shift the transmission back to FORWARD to resume harvesting.

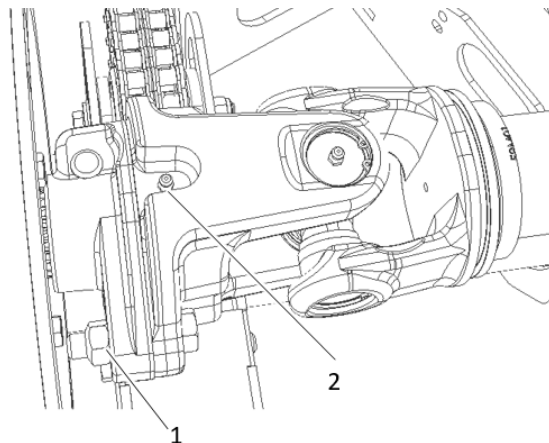

Figure 87 Cutter head drive shaft shear bolt

OPERATION

FRICITION CLUTCH (OPTIONAL)

As an option, a friction clutch can replace the shear bolt overload protection (on demand and for specific cases, contact your dealer).

NOTE: When a friction clutch is used, power is still transmitted to the cutter head during slippage, but may burn quickly if not stopped during an overload situation.

When slippage occurs, and the feed rolls are in FORWARD motion, the harvester controller will initiate an emergency stop (models equipped with *FerroDtec*).

An intermittent failure alarm (4/5s ON – 1/5s OFF) is activated and the transmission shifts back to NEUTRAL to avoid a feed roll or header blockage.

1. Stop the PTO, shut the tractor off and wait for all rotating parts to come to a complete stop.
2. With the harvester in NEUTRAL, turn the feed rolls manually to clear the header and inlet.
3. Clear the feed rolls or header if any crop remains.
4. Start the tractor, engage the PTO at low speed with the harvester in NEUTRAL, and accelerate the engine speed quickly to clear the harvester.

NOTE: Clean the processor rolls if needed (see on page 73).

CLEANING THE PROCESSOR ROLLS

FIGURE 88

If a safety shear bolt is broken or the PTO has been accidentally stopped while operating, material accumulated between the processor rolls and the cutter head must be removed. Follow this cleaning procedure:

1. Stop the PTO, shut the tractor off and wait for all rotating parts to come to a complete stop.
2. Open the top cover (item 1) and secure it opened with the safety latch (item 5).
3. Open the cleaning doors (item 2).
4. Use the scraper (item 3) down between the cutter head and the upper roll, first with the narrow side.
5. Scrape material out through the cleaning slotted holes (item 2 or 4).
6. When the cleaning is done, close the top cover and the small cleaning doors. Engage PTO to completely clean the area between the rolls and the cutter head. Then, completely stop everything as stated in Step 1 and check if the cleaning is adequate. If not, carry out the procedure once more.

IMPORTANT: Clean the belt area from any debris to avoid damaging them.



WARNING: Be careful when working inside the cutting chamber. A piece of wood should block the cutting head in order to prevent any sudden rotation of the knives.

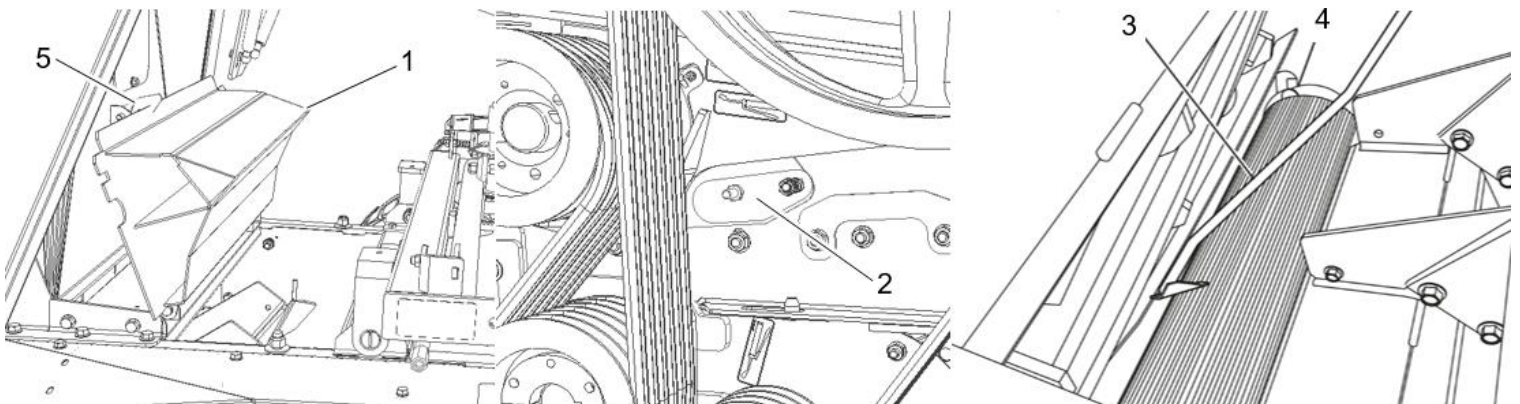

Figure 88 Cleaning the processor rolls

OPERATION

TRANSPORT

TRANSPORT ON PUBLIC ROADS - FIGURE 90



WARNING: When a trailer or other piece of equipment is attached to a forage harvester using a manual, electric or hydraulic quick release coupler (item 3), the locking pin (item 4) must be installed before accessing a public road or hilly terrain. An appropriately rated safety chain for the equipment being towed must also be installed. Also, the safety cover for the hitch release switch must be lowered on the control box and the control box must be turned off. Finally, the hydraulic flow to the forage harvester must be stopped to avoid any unexpected action.



WARNING: Securely attach the forage harvester to the tractor. Use an approved hitch pin of the appropriate size with a mechanical restraint system and attach a safety chain with a capacity of at least 20,000 lb (9071 kg) (Figure 18, Figure 19 Cat. II drawbar extension on pages Figure 18 & Figure 19 Cat. II drawbar extension respectively).



WARNING: Never hitch a loaded trailer behind a forage harvester on a public road.

Before transporting the harvester on the road, take the following precautions.

1. Clean the harvester of any debris that may fall on the road during transportation.
2. Set the drawbar (item 3, Figure 90 Transport on public roads) in transport position. Secure it using the locking pin (item 4) provided.
3. Raise the header and lock the lift cylinder by pulling the locking handle completely outwards (See item 6, FIGURE 90 Transport on public roads).
4. For models equipped with the 'Stinger' spout extension, rotate it to transport position (full forward position) and lower it completely. (The lowest cylinder position is limited to maintain a suspension stroke). In this position, make sure the spout is properly locked (FIGURE 89).

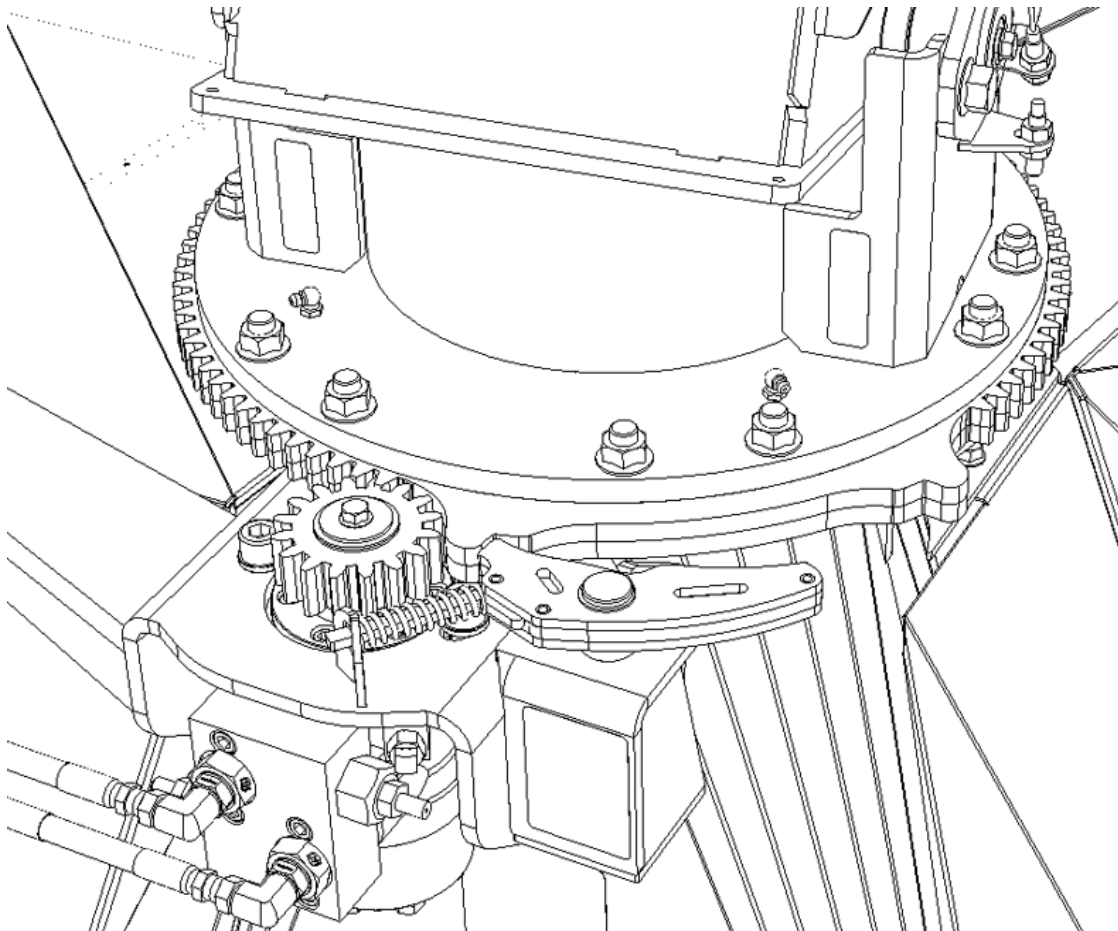

Figure 89 Spout in locked position

OPERATION

5. For models with short spout, ensure it does not protrude from either side of the harvester and that the tip height is well below the allowable public road max height.
6. Shut off the hydraulic flow to the harvester.
7. Turn off the control box.

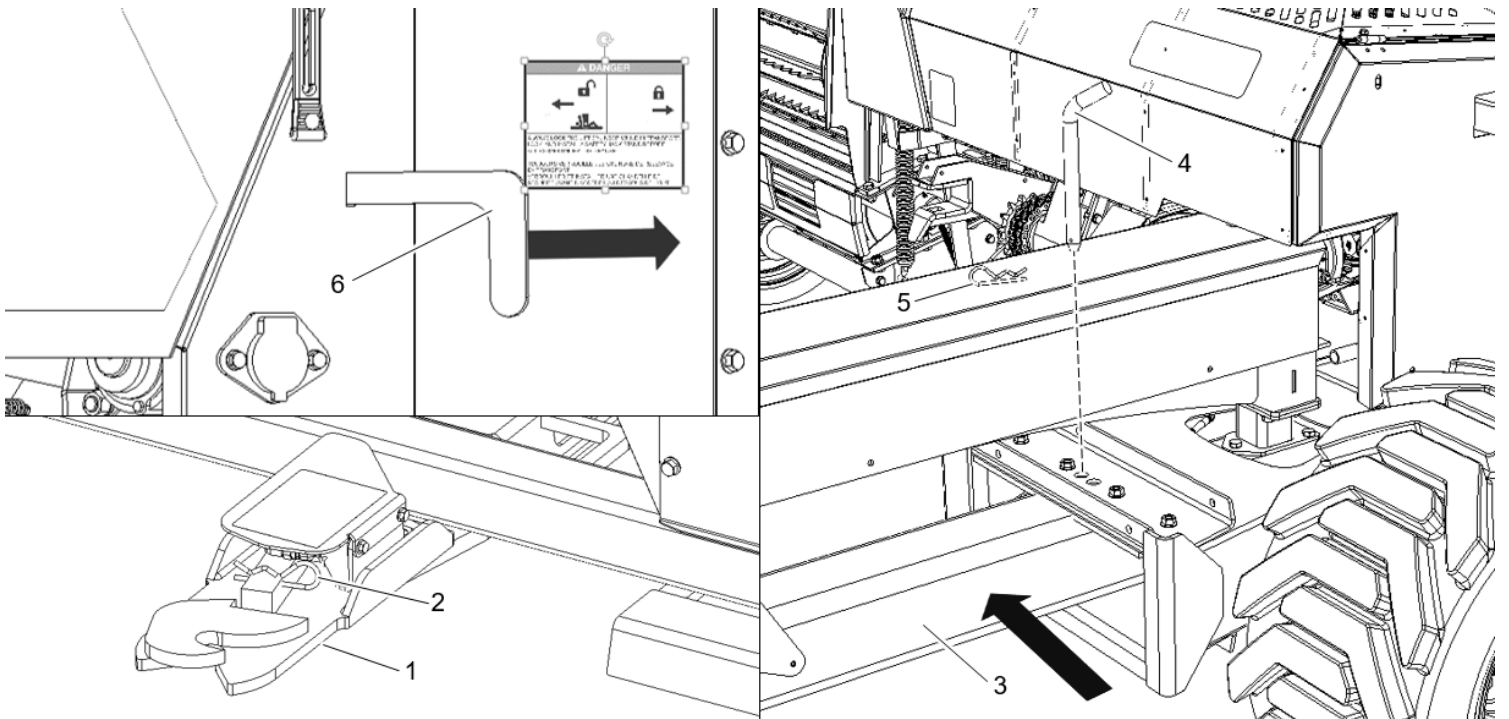

Figure 90 Transport on public roads

MAINTENANCE & ADJUSTEMENTS



DANGER: Never lubricate or service the machine when the PTO is operating and/or the tractor engine is running.



WARNING: Never open guards/shields/doors or make adjustments while the machine or tractor engine is running.



WARNING: Make sure all guards, shields and doors are in place and properly secured before starting the tractor engine. When adjustments have been done, check the machine thoroughly for possible loose parts or bolts.



WARNING: Never park or work on a machine without first having blocked the wheels and applied the parking brakes on the tractor.



WARNING: Never leave an operator in the tractor cab when performing a machine maintenance or inspection. Also, for your own safety, instruct anyone standing in the immediate surroundings to keep a safe distance from the harvester (e.g. a distance of at least 3 m or 10 ft).



WARNING: Ensure all moving parts have come to a complete stop before opening any guards, shields and doors or servicing the harvester.

IMPORTANT: *Lubrication and greasing at the proper frequency and quantity will minimize the wear and tear of the components, thus reducing the possibilities of breakdowns.*

HYDRAULIC CIRCUITS

The forage harvester is equipped with a hydraulic system to operate most of its functions. Make sure the hydraulic oil level on the tractor is sufficient, that the oil is clean and of proper quality. Likewise, ensure the hydraulic couplers and tractor valve couplers are thoroughly cleaned before connecting them.

POWER TAKE OFF (PTO)

To prevent the telescopic shafts on the PTO from blocking, grease as recommended.







DRIVE CHAINS

To maintain the roller chains, always use specifically formulated oil. Never apply grease on drive chains. Chains that have accumulated dirt or debris should be clean with solvent and dipped in oil to avoid premature wear. As per manufacturer specification, the chain life is limited to a 1.5% stretch from its theoretical length.

MAINTENANCE & AJUSTEMENTS

LUBRICATION CHART

The symbols in the chart below indicate specific points which should be greased, oiled and verified:

SYMBOLS	DESCRIPTION	FREQUENCY
Black on White 	Grease - 52 points	According to frequency indicated on the decal
 SAE30 or equivalent	Oil - 46 points	Oil every 12 hours of operation
 80W140 semi-synthetic	80W140 synthetic	Change once a year
		Change once a year or every 500 hours
	Oil level on gear boxes	Check every 100 hours of operation. Add oil if necessary.
	Drain plugs on gear boxes	
	Wheel hubs (2) or (4) (tandem)	Grease and adjust once a year

GEARBOXES LUBRICATION

The gearbox oil level must be checked and adjusted after the first ten (10) hours of operation, at the beginning of every season and at least every 100h of operation.

Synthetic 80W140 oil is recommended (available in 1l containers from DION-Ag Inc. - Parts Department - # 30671) for both gearboxes.

Fill up to the sight glass level (See Figure 93 Angle drive gearbox & Figure 94 Main gearbox, spout rotation and hydraulic trailer disconnect).

Drive shafts and CV joints must be greased daily.

MAINTENANCE & AJUSTEMENTS

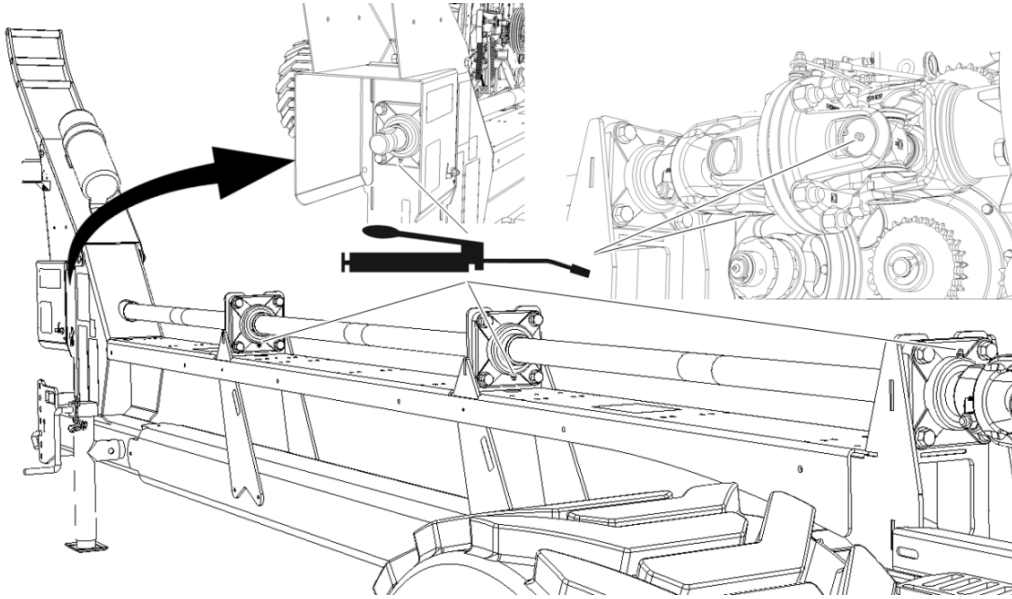

Figure 91 Universal joint and drawbar bearings

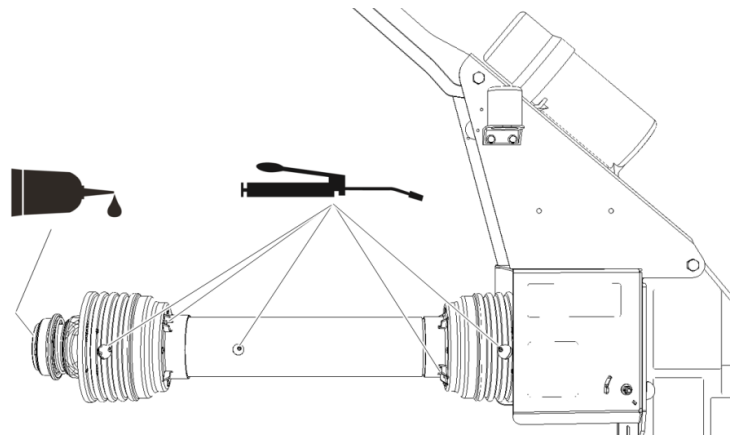
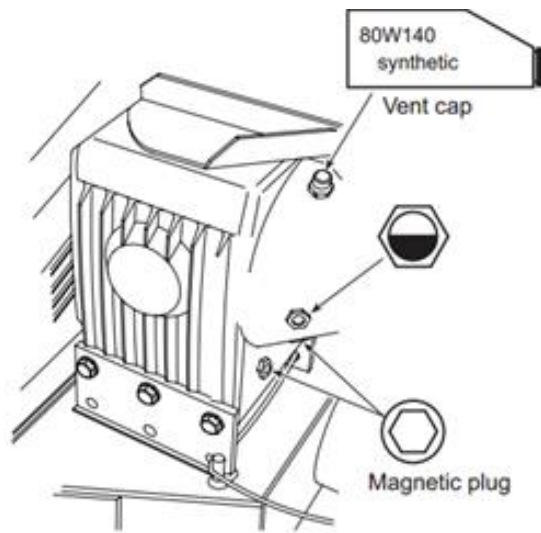

Figure 92 Front PTO



CAPACITY: 8 L (2.1 US Gal.)

Figure 93 Angle drive gearbox

MAINTENANCE & AJUSTEMENTS

IMPORTANT !

Every 100 hours
of operation maximum

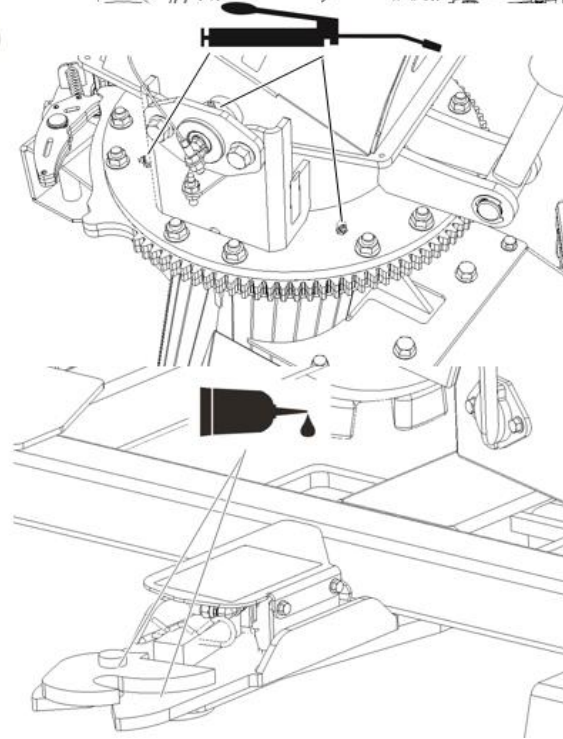
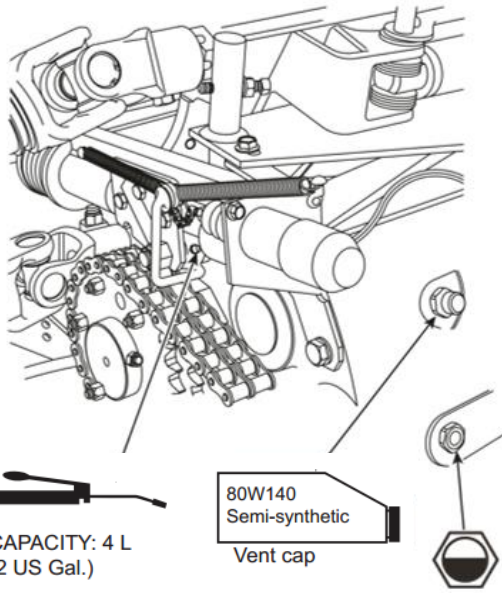
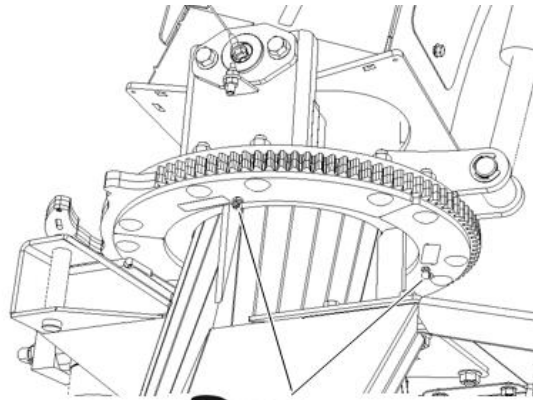
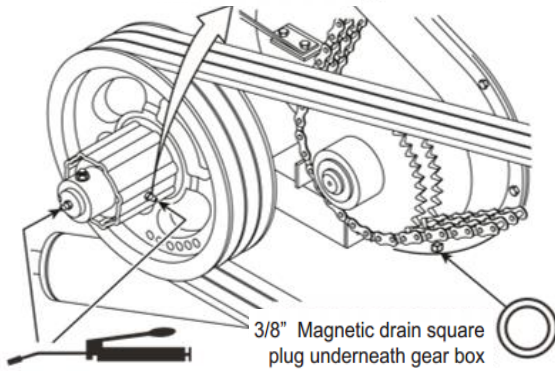

Figure 94 Main gearbox, spout rotation and hydraulic trailer disconnect

MAINTENANCE & AJUSTEMENTS

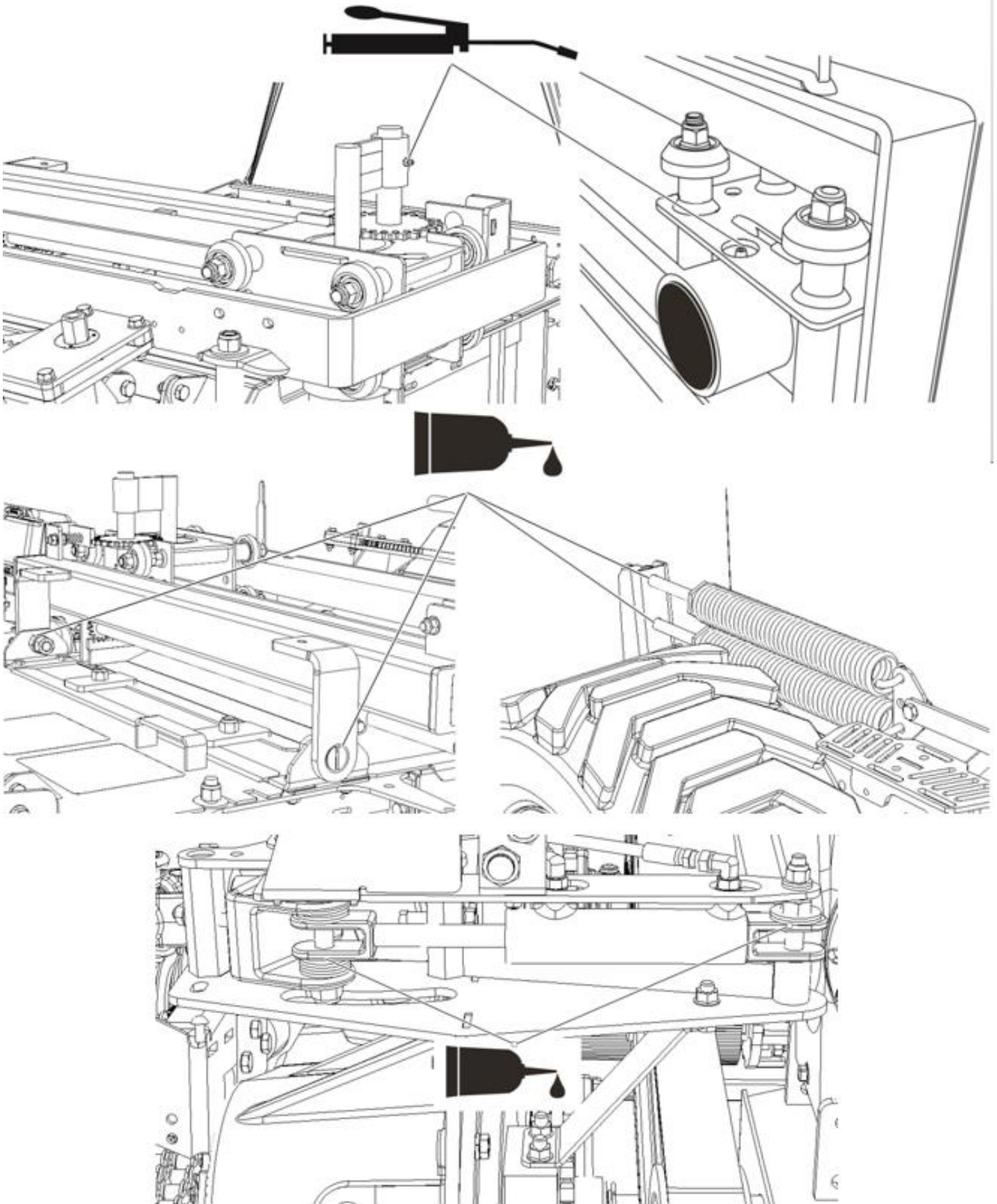

Figure 95 Knife grinder, suspension springs and transmission shifter

MAINTENANCE & AJUSTEMENTS

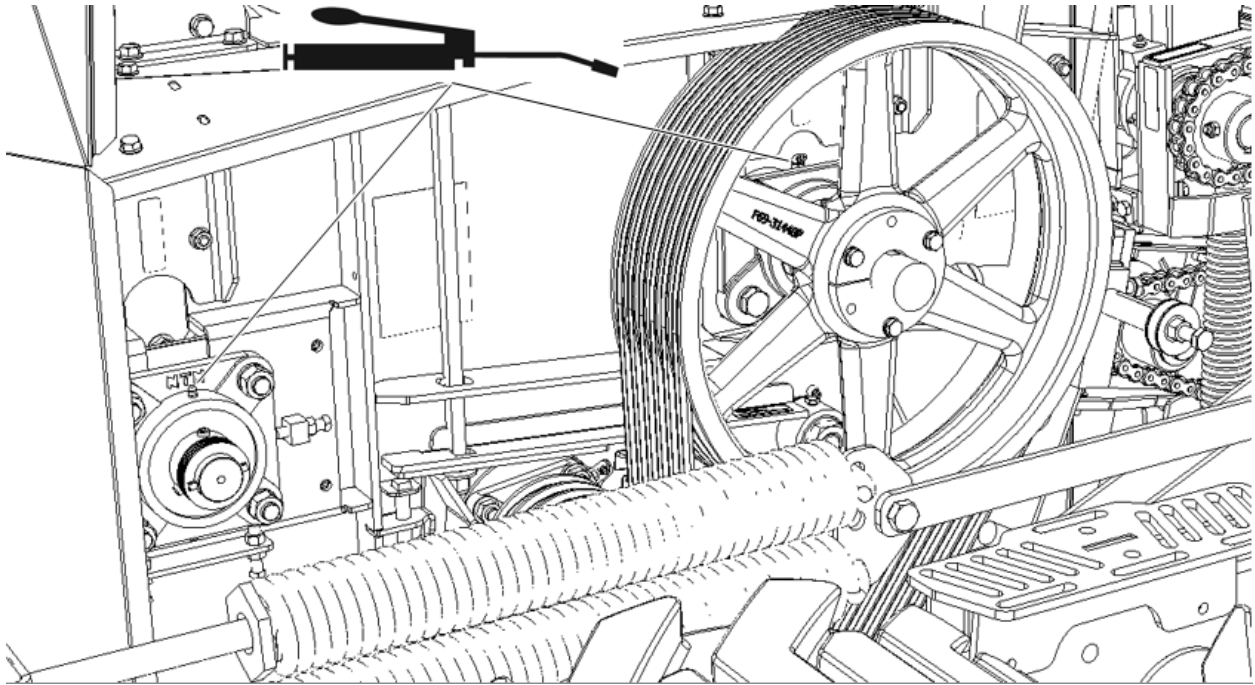

Figure 96 Cutter head and blower bearings (each side – 4 points)

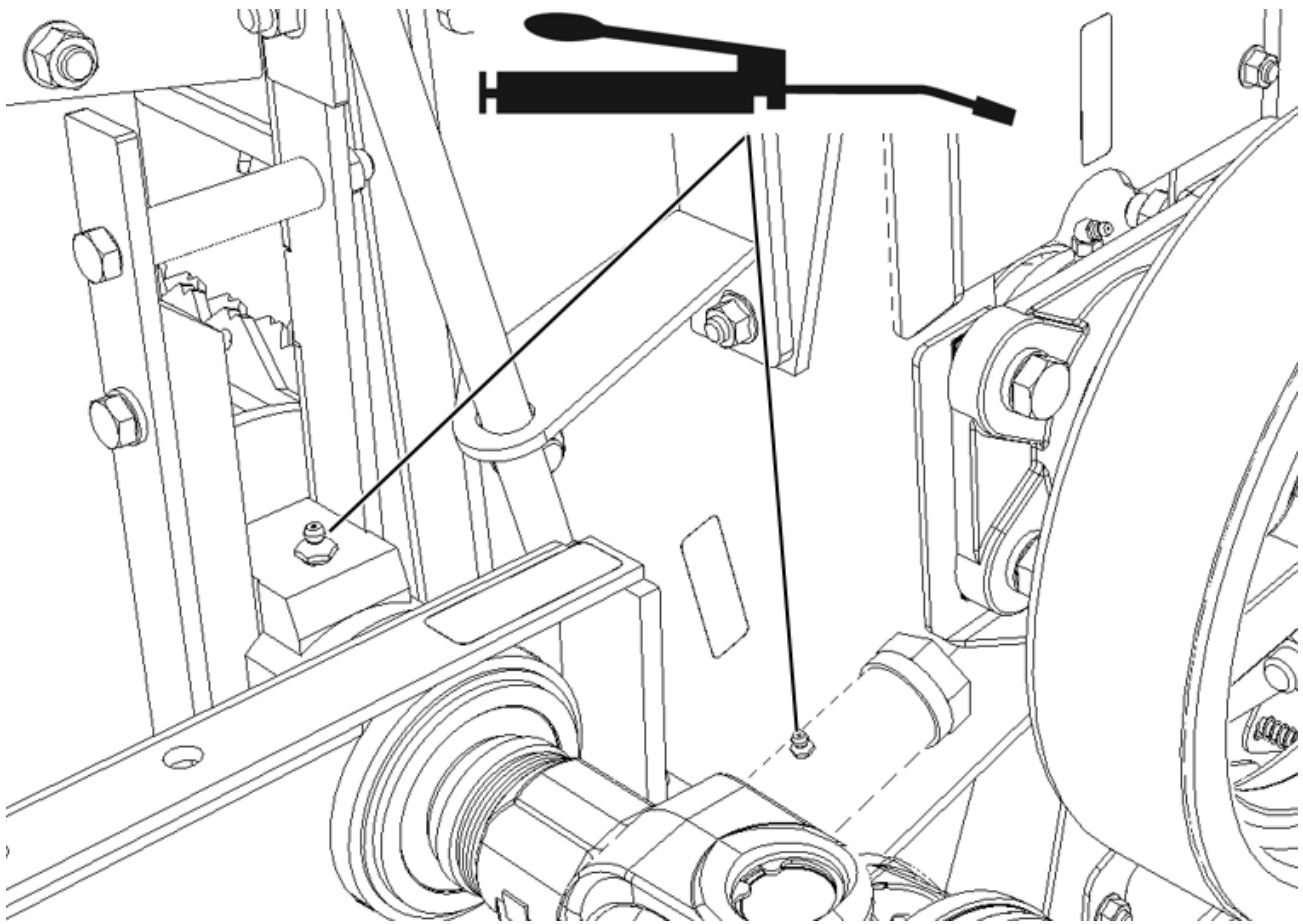

Figure 97 Feed roll slider, shear bar spring plunger (each side – 4 points)

MAINTENANCE & AJUSTEMENTS

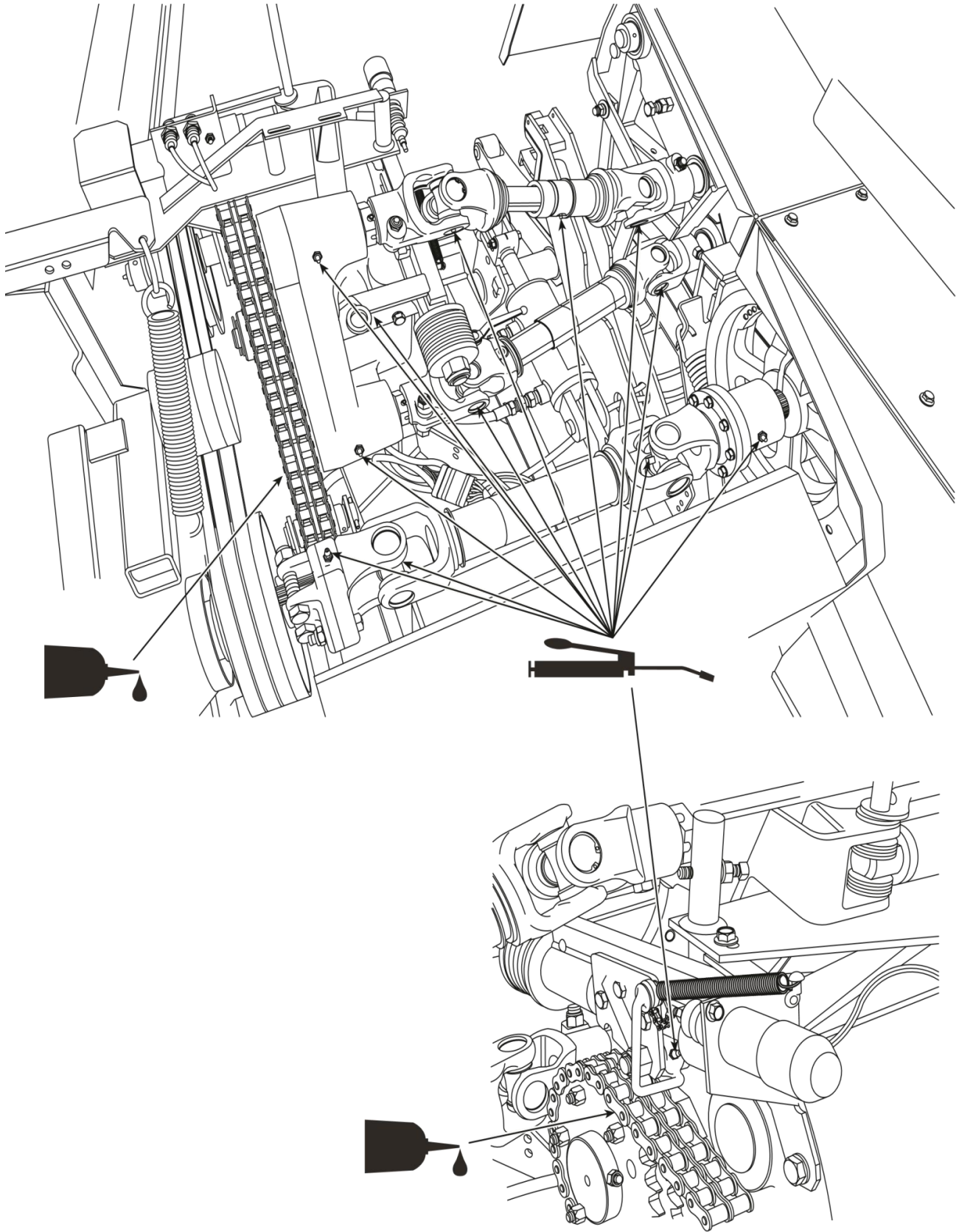

Figure 98 Universal joints, transmission chain

MAINTENANCE & AJUSTEMENTS

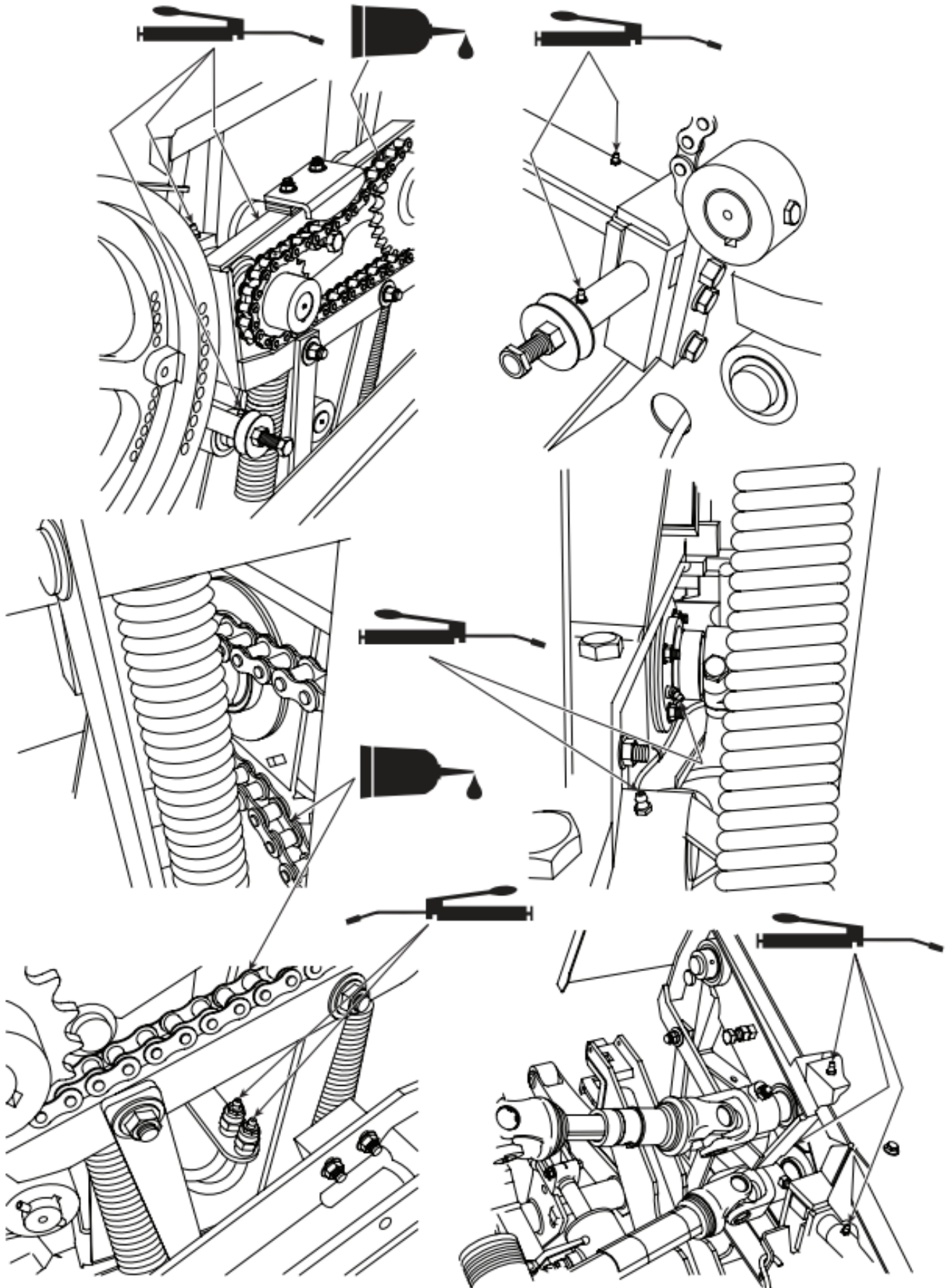

Figure 99 Feed rolls linkage, bearings and chains

MAINTENANCE & AJUSTEMENTS

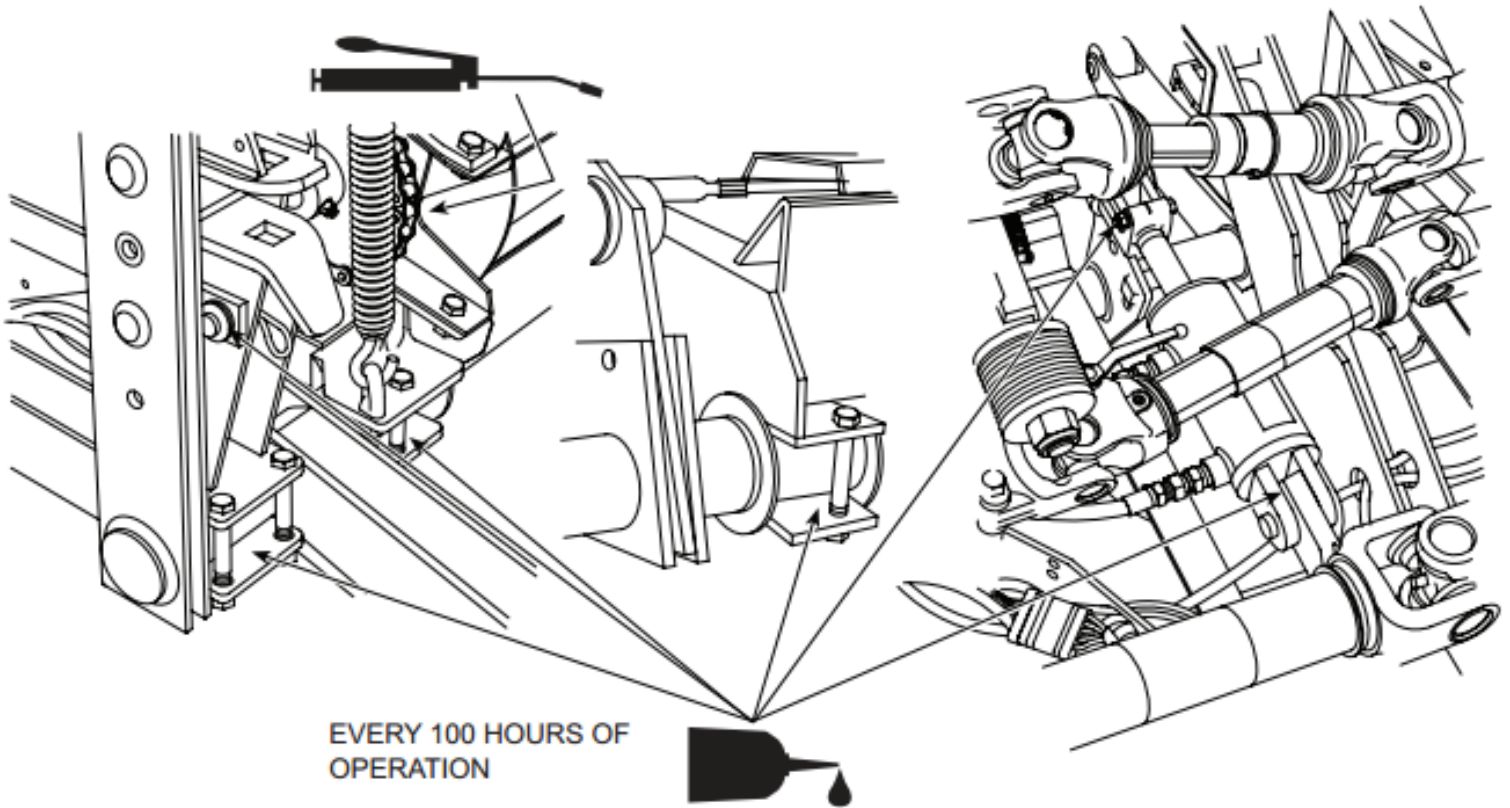





Figure 100 Header lift arms and cylinder

PROCESSOR ROLL LUBRICATION

In wet conditions, harvesting silage may produce large amounts of fluid when passing through the processor rolls. This fluid may contaminate the roller bearings. It is **highly recommended** to increase the greasing frequency of the grease chambers behind the bearing (item 1) every **4 hours** of operation.

SYMBOL	DESCRIPTION	FREQUENCY
White on Green 	High-speed grease 4 points	2 pump strokes every 40 hours of operation
Black on White 	Standard grease - 8 points	Grease periodically. See illustration below for frequency
	Threaded rods - 6 points	Oil periodically

MAINTENANCE & AJUSTEMENTS

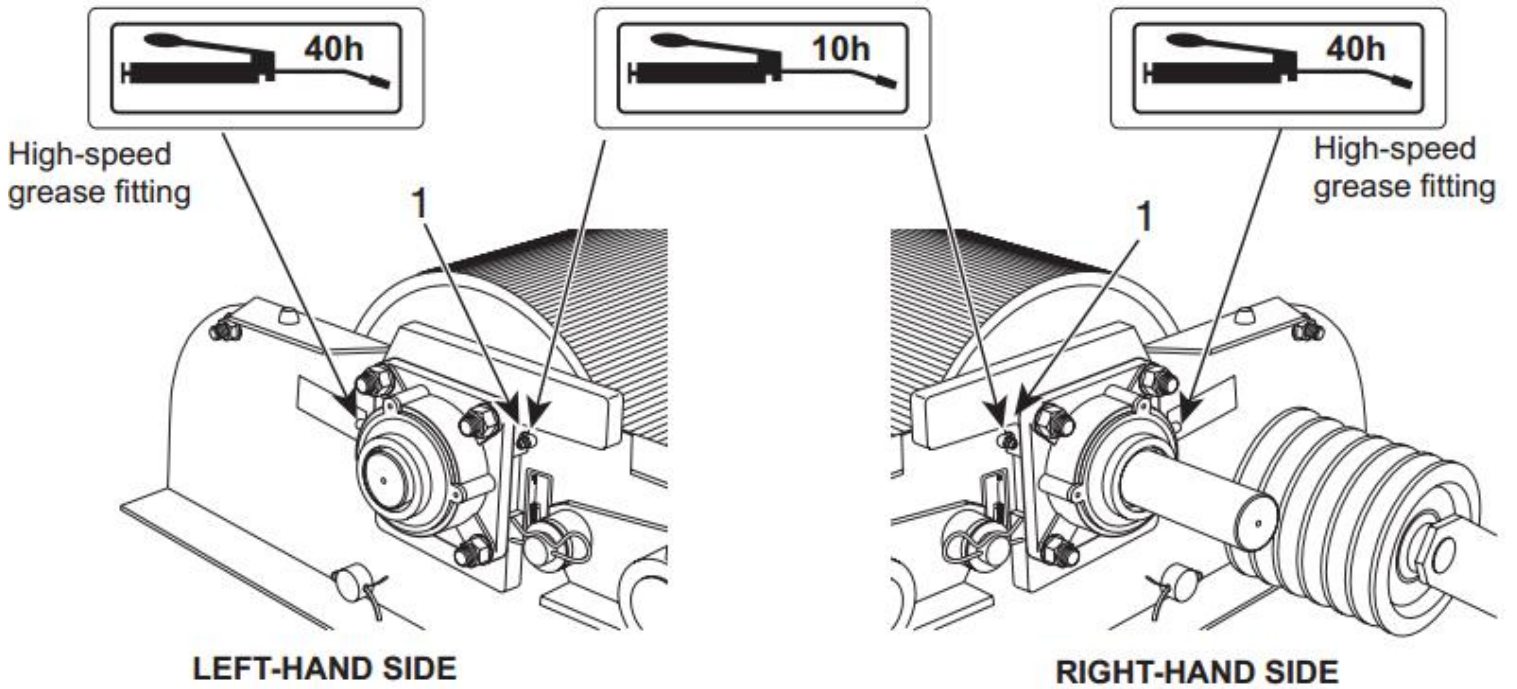

Figure 101 Sealed grease chamber behind the roller bearings

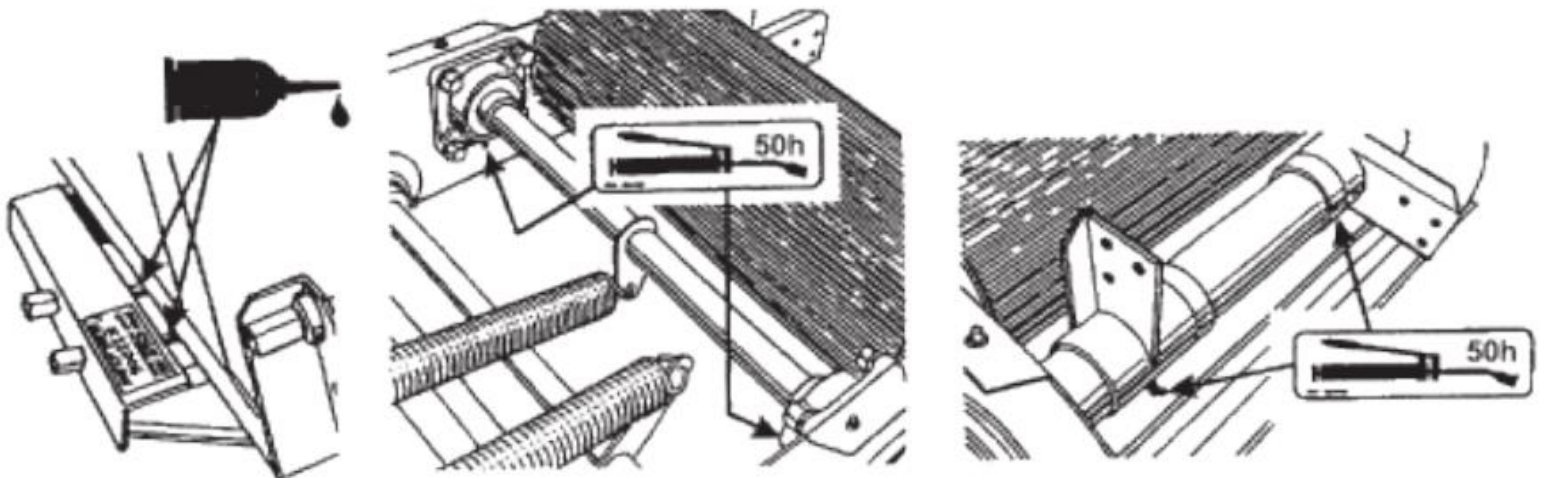
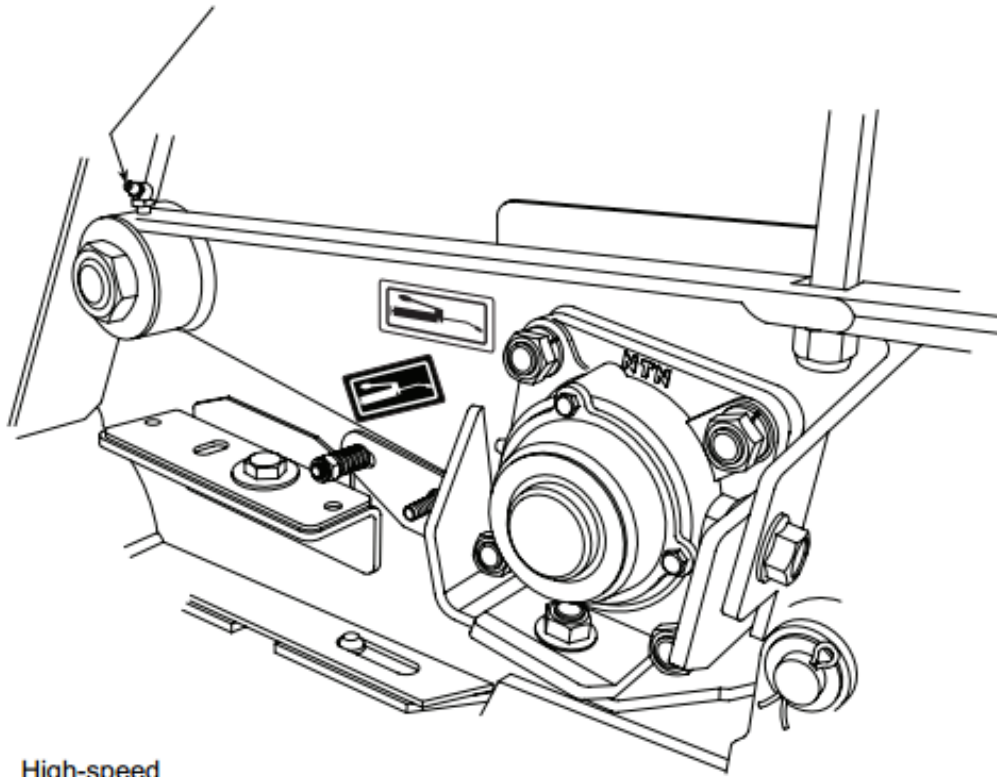
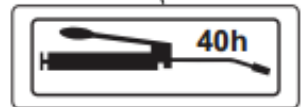
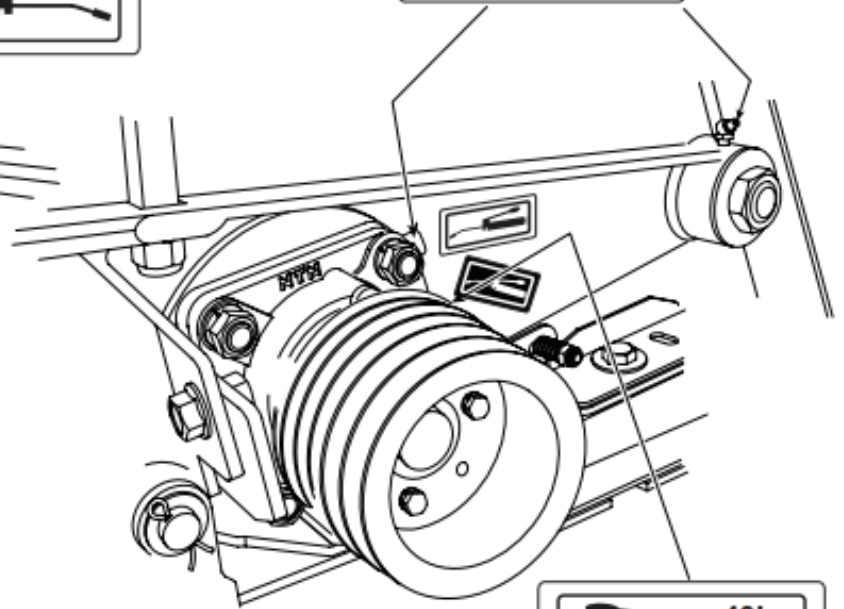
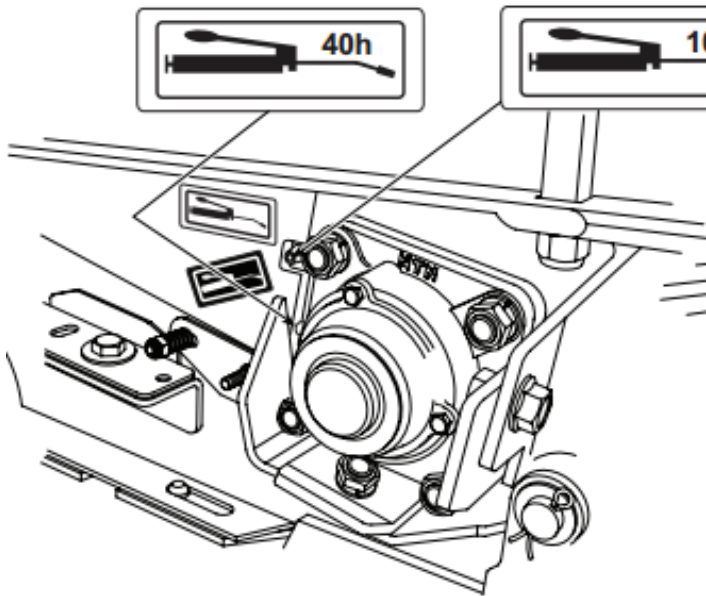

Figure 102 Processor rolls lubrication

MAINTENANCE & AJUSTEMENTS



High-speed
grease fitting



LEFT-HAND SIDE

RIGHT-HAND SIDE

High-speed
grease fitting

Figure 103 Processor rolls lubrication

MAINTENANCE & AJUSTEMENTS

SMOOTH FEED ROLL SCRAPER ADJUSTMENT

FIGURE 104

The scraper (item 1) should always be installed as close as possible to the smooth feed roll (item 4). To adjust, loosen bolts (item 2) and nuts (item 3). To make this adjustment easier, open the cutter head cover to gain access to the assembly (item 1 - Figure 108 Shear bar replacement).

NOTE: The cleaner (item 1) should be adjusted at a maximum 0.005" (0.12mm) from the smooth feed roll to prevent material from accumulating between these two components.

NOTE: It is recommended to check and reposition the cleaner every 100 hours of operation.

NOTE: Always install with the special washers in place (item 5).

When the cleaner (item 1) requires cleaning, it should be removed from the right-hand side of the Forage Harvester. If it is worn or bent, it should be replaced. To remove the cleaner, remove bolts (item 2), nuts (item 3) and all of the hardware and spacers before pulling it out.

In any situation, if the smooth feed roll (item 4) rotates with difficulty, this will cause the chain and sprocket to wear prematurely and consequently will cause an unnecessary loss of power.

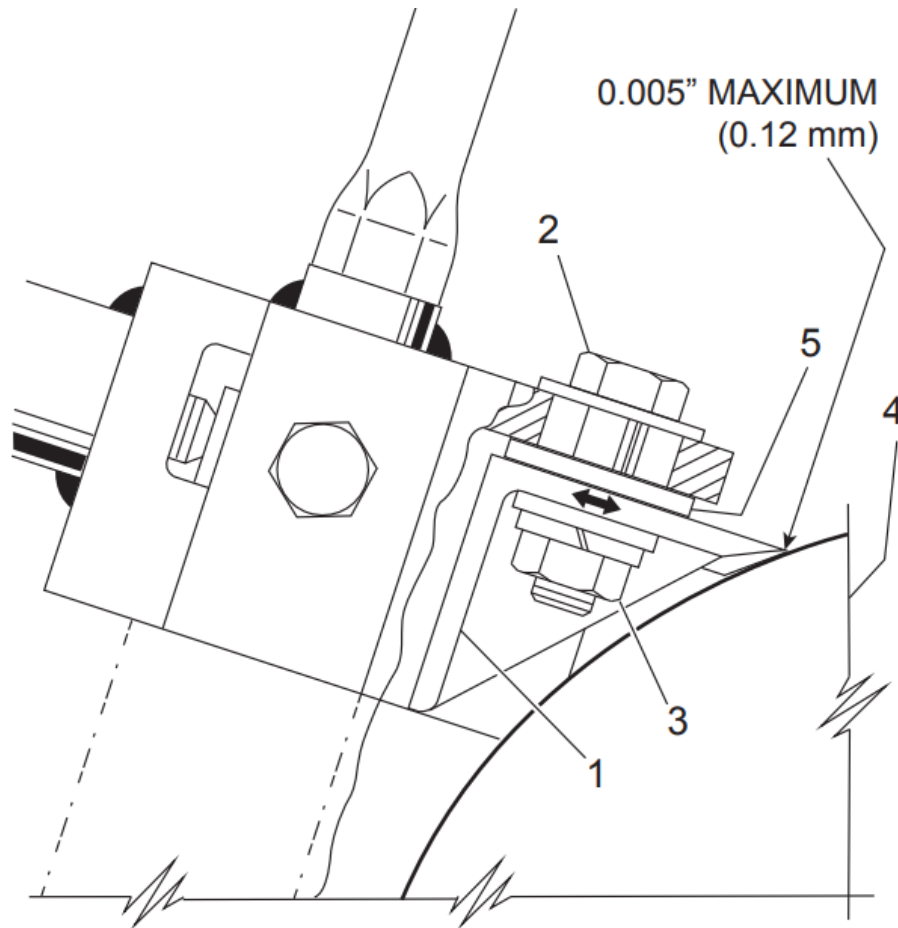

Figure 104 Smooth roll scraper adjustment

MAINTENANCE & AJUSTEMENTS

KNIFE ADJUSTMENT

FIGURE 105



WARNING: Always disconnect the harvester from the tractor for the knife adjustment operation.
WARNING: Always proceed with the knife adjustment with great precautions.



WARNING: Be careful when working inside the cutting chamber. A piece of wood should block the cutting head in order to prevent any sudden rotating motions from the latter.

The Forage Harvester knives should be readjusted after successive grindings have shortened them by approximately 1/4" (6mm) since the shear bar cannot be moved forward by more than this distance.

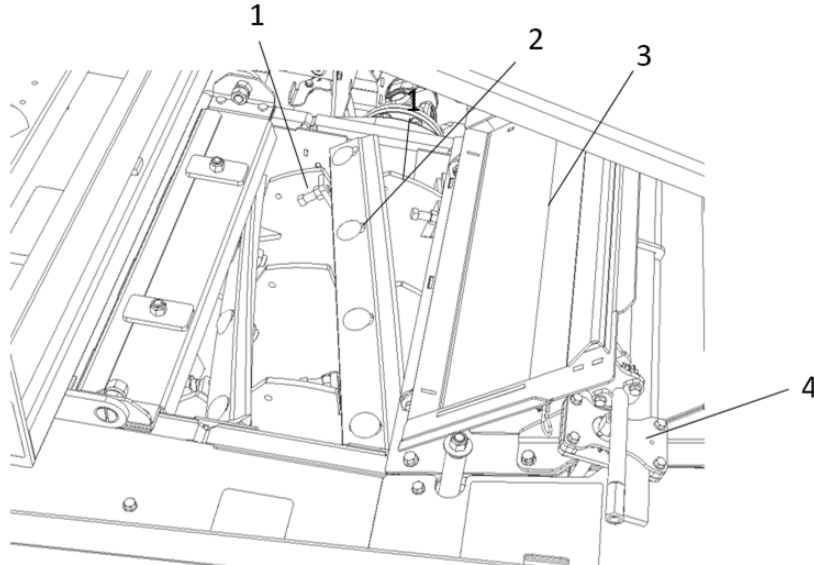

Figure 105 Knife replacement

To adjust the knives:

1. The day prior to adjusting the knives, clean and apply oil on all cutter head bolts (item 1 and 2).
2. Remove the shear bar, lift the sharpening assembly and cutter head cover (or the whole cutter head shield assembly and rack-and pinion assembly (items 3 and 4).
3. Loosen the knife bolts (item 2) and adjusting screws (item 1) supporting the knives.
4. Locate the round guide bar which is stored above the feed rolls. Insert the bar in the holes meant for this operation on the side of the frame above the cutterhead (see arrow). The bar is used as a guide for the knife adjustment.

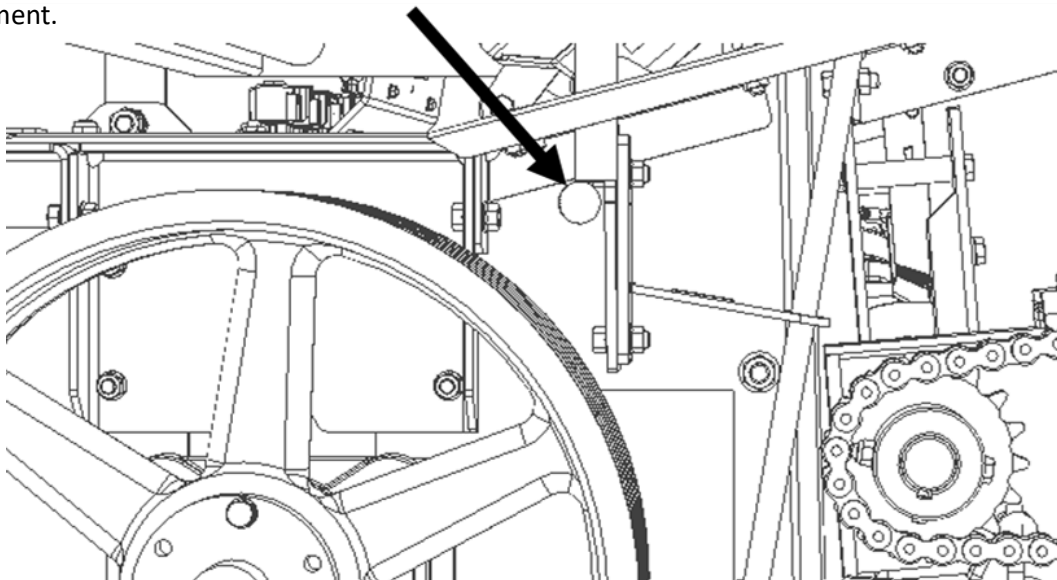

Figure 106 Knife guide installation

MAINTENANCE & AJUSTEMENTS

5. The 2 adjusting screws (item 1) on the back side of each knife will be used for adjusting the knives. They should be adjusted to where the knives just start to touch the guide bar along its full length.
6. Slightly tighten the four knife bolts (item 2) and verify knife adjustment against the guide bar. Readjust, as necessary, by using the two screws (item 1) on the reverse side of each knife. After the adjustment is completed, tighten the four knife bolts (item 2) permanently to 300 - 320 lb-ft (407 to 434 Nm).
7. Once the knives are perfectly adjusted, remove the guide bar and reinstall the shear bar, taking care to choose the side with the best cutting edge. Install the cutter head cover and its support (items 5 and 7). Follow up with knife sharpening in order to obtain a good cylindrical cutter head (see KNIFE SHARPENING section page 53).

KNIFE REPLACEMENT

Knives are sold in **matched pairs**. When replacing knives on the cutter head, always install in matched pairs, 180° opposite each other, to maintain proper balance. If you modify or sharpen the knives while they are not installed on the cutter head, make sure they have the same weight before reinstalling them 180° opposite each other. The maximum weight difference between two knives should be 25 grams. See the previous section for KNIFE ADJUSTMENT or for installation information.

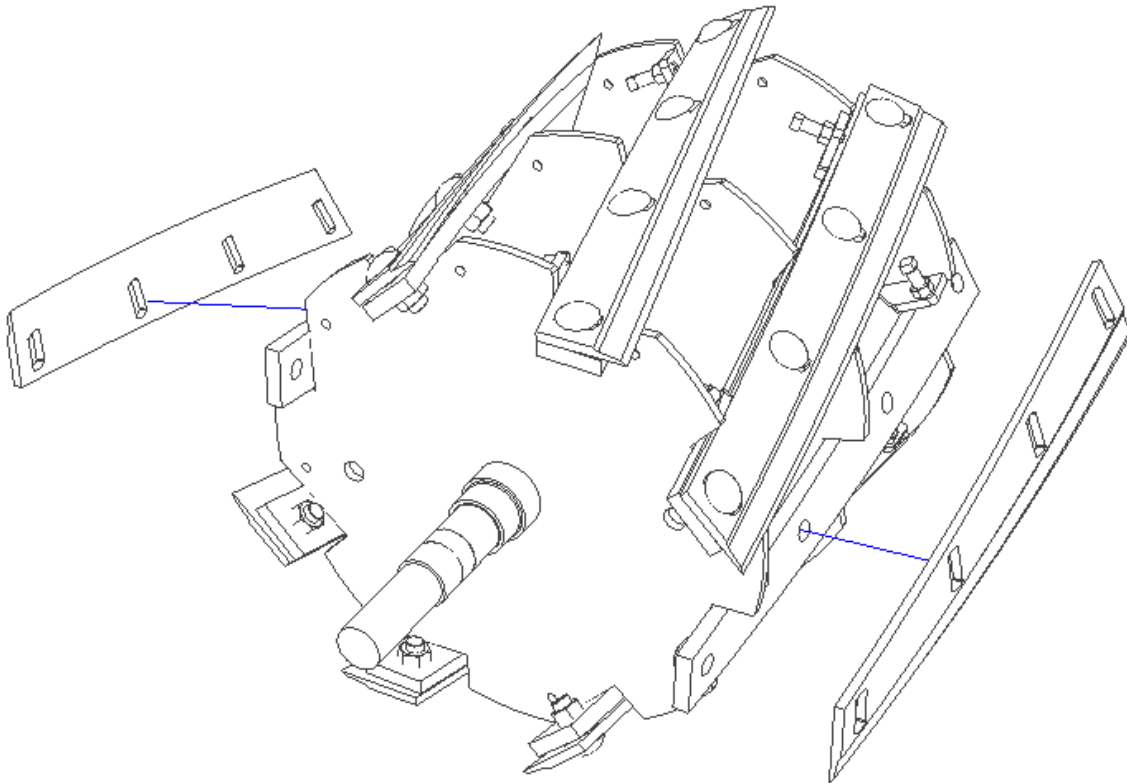

Figure 107 Knife replacement

MAINTENANCE & AJUSTEMENTS

SHEAR BAR REPLACEMENT

FIGURE 108, FIGURE 109, FIGURE 110

NOTE: Always position the tungsten edges facing upwards (on top).

The shear bar cutting edge will remain sharp longer providing all knives have been properly sharpened and the shear bar is adjusted every time the knives are sharpened. When the cutting edge becomes excessively worn, the shear bar can be removed, turned around and then reinstalled.



WARNING: Stop the PTO and shut off tractor engine before servicing or performing maintenance. Refer to SAFETY RULES on page 12.

To replace the shear bar, proceed as follows:

1. Open the shear bar cover (item 1 to access and clean the shear bar area (item 2).

NOTE: On the earlier models, the shear bar must be removed towards the inside of the harvester. On later models, the adjustment module is removable to allow the bar to be pushed out towards the right-hand side of the harvester. A kit is available for purchase to update the older models to the removable module configuration for easier shear bar maintenance. Contact your dealer about Service Bulletin #FH2002.

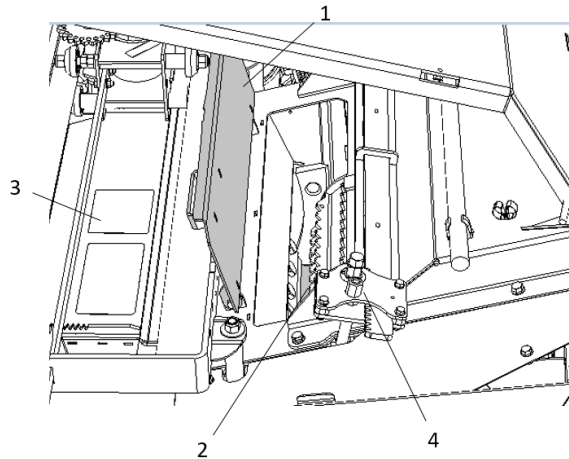

Figure 108 Shear bar replacement

2. Loosen the shear bar clamping rod (item 4 - Figure 108 Shear bar replacement). Loosen the pointer nuts and screws (item 5) completely to clear the path for the shear bar and then unscrew the adjuster bolt (item 6).

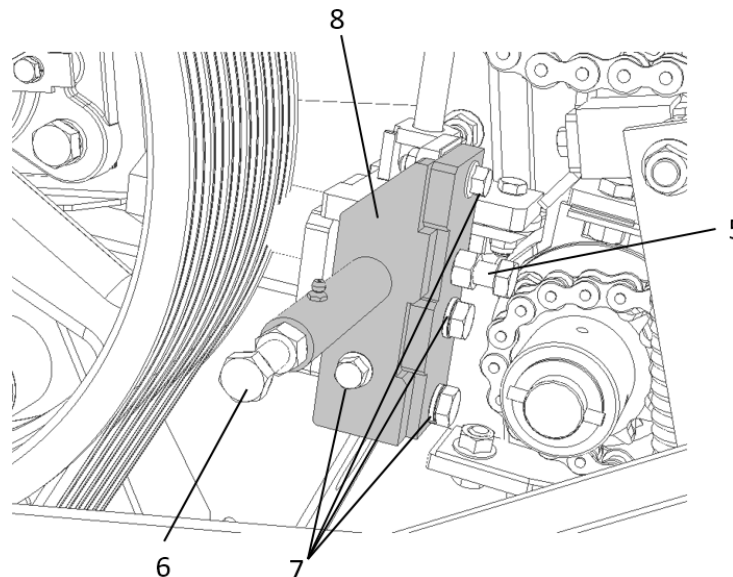

Figure 109 Shear bar replacement

MAINTENANCE & AJUSTEMENTS

3. Remove the shear bar adjuster module (item 8, see note above for serial# 8XXXXX1.) by removing bolts (item 7).
4. Remove the shear bar (Figure 110 Removing the shear bar), clean it, and verify the condition of the cutting edge.
 - a. If the worn edge is still sharp and the bar is straight, reinstall in the same position.
 - b. If 1 edge is worn or rounded but the bar is straight, reinstall with the sharp edge towards the knives.
 - c. If the bar has worn out both tungsten edges or is bent or warped, replace it.

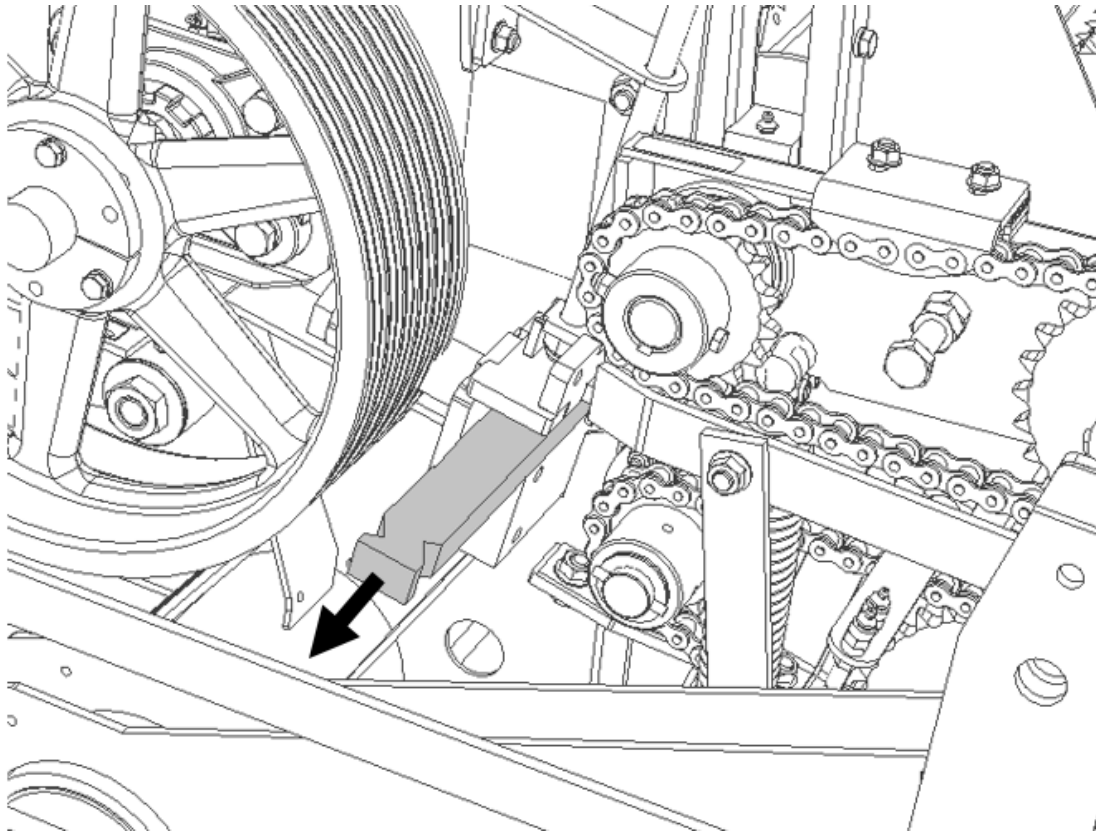

Figure 110 Removing the shear bar

5. Thoroughly remove the forage debris between the bar and the smooth roll cleaner and between the shear bar and its support.
6. Coat the entire underside of the shear bar with a thin layer of “never seize” to ensure movement when adjusting.
7. Reinstall the shear bar back in place.

NOTE: Always install the shear bar with the tungsten carbide facing upwards.

NOTE: Position the shear bar so that the parallelism adjustment screws (item 1) are embedded in the notches of the bar (see arrow Figure 111 Shear bar initial adjustment).

IMPORTANT: Apply “Never Seize” to all bolts and the bottom of the shear bar (items 5 and 6) every time a shear bar is replaced.

MAINTENANCE & AJUSTEMENTS

SHEAR BAR INITIAL ADJUSTMENT

To make the initial adjustment of the shear bar, do the following:

NOTE: Ensure the tungsten faces upwards.

NOTE: This adjustment must always be performed after sharpening the knives.

1. Position the bar while ensuring the pointers (item 1) are properly inserted in the bar notches.
2. Adjust the shear bar parallel to the knives by using the adjustment screws (item 1) on both sides of to obtain a precise (0.005") and uniform gap across the whole width. Tighten the bar with clamping screws (item 4) and recheck the bar clearance.
3. Tighten to apply light pressure the adjuster bolt (item 3), that is used for subsequent sharpening. Tighten its locking nut.
4. Close the traps and guards over the cutter head.
5. Regularly check the quality of cut during the first hours following this adjustment. If the cut is not precise even after a shear bar clearance adjustment (DAILY SHEAR BAR ADJUSTEMENT, page 54), check parallelism.

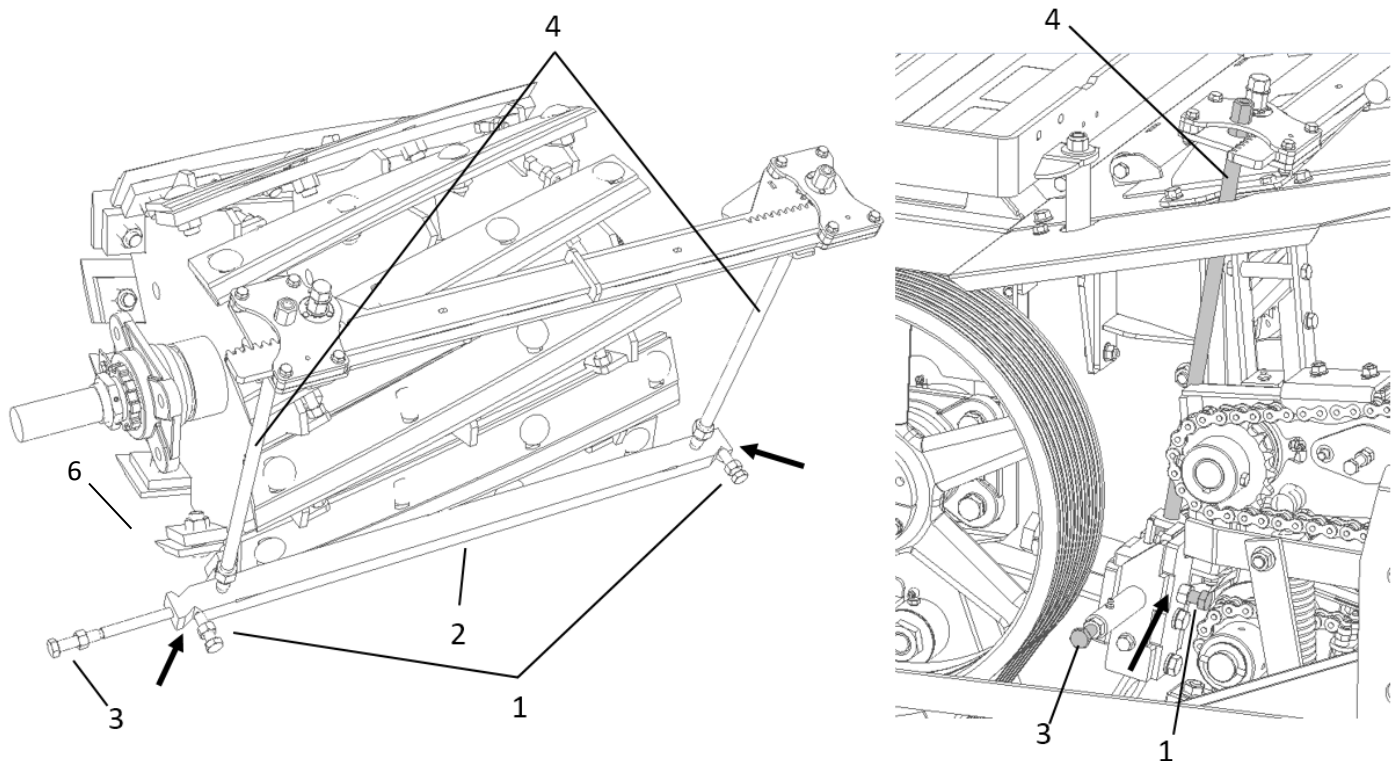

Figure 111 Shear bar initial adjustment

NOTE: All bolts used for the shear bar adjustment are special bolts, never use standard bolts.

NOTE: It may be useful to remove the guards over the cutterhead for better access and clean up of the shear bar for easier access to do the adjustment. This adjustment will remain constant until the knives been worn out by ¼" (6mm).

NOTE: Use feeler gauges to obtain a precise adjustment.

SHEAR BAR CLAMPING ADJUSTMENT

FIGURE 112 TO FIGURE 114

NOTE: *Inspect and verify the clamping adjustment approximately every 100 hours of operation or at the start of each season.*

NOTE: *Do this only after checking that the initial shear bar adjustment is adequate. See SHEAR BAR INITIAL ADJUSTMENT.*

IMPORTANT: *An incorrectly tightened rack may cause premature wear of the shear bar or damage.*

It is essential that the shear bar is securely tightened after every adjustment. The rack allows you to do this on one side of the forage harvester. The rack operates the far side locking rod and the available travel of the rack must be sufficient to completely tighten the rod. If the rack reaches its full stroke before the rod is fully tightened, the shear bar will not be properly clamped in place. An unstable shear bar will be subjected to vibrations which can damage it or cause damage elsewhere within the forage harvester.

To inspect and adjust the rack:



WARNING: Stop the PTO and turn off the tractor engine before adjusting the rack. Refer to SAFETY RULES on page SAFETY RULES.

1. When the far side locking rod is fully tightened with the rack and pinion, one or two teeth must be visible on the near end of the rack assembly as shown.

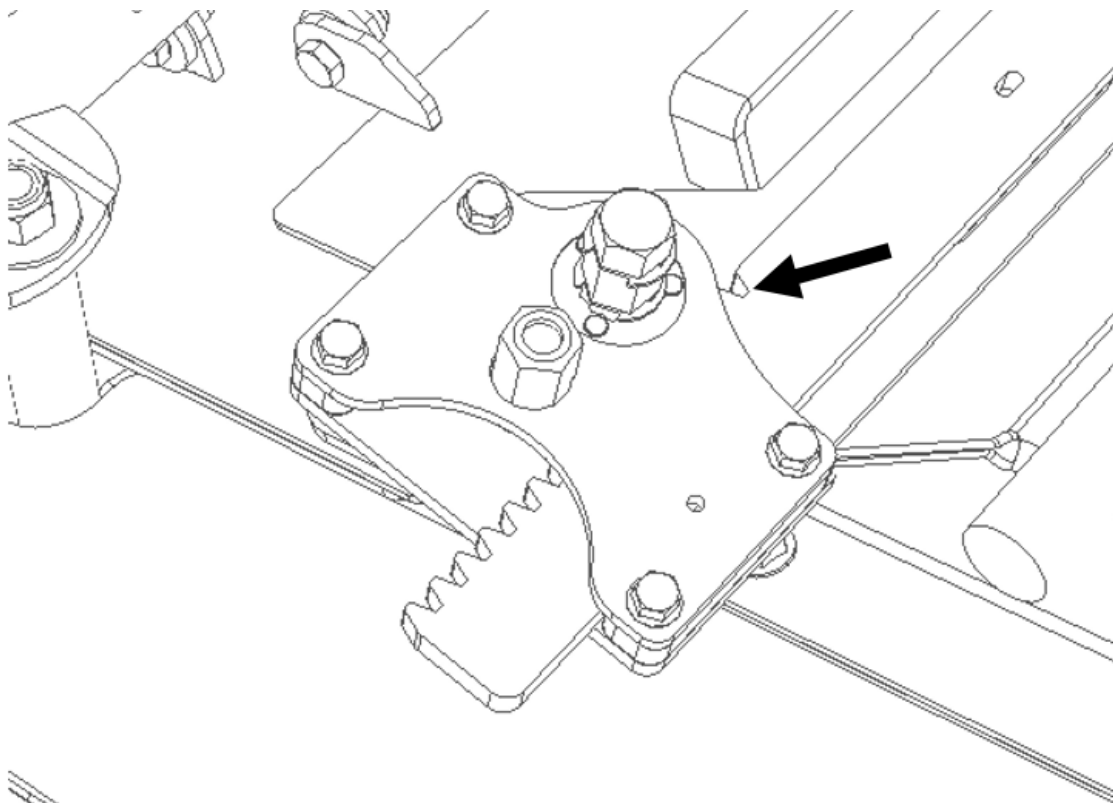

Figure 112 Rack & pinion adjustment

2. If less than one tooth is visible, the rack should be readjusted.

MAINTENANCE & AJUSTEMENTS

3. To make an adjustment, remove the clamping hardware and top plate of the **far side locking rod only**. Then remove the gear.
4. Tighten the far side locking rod (item 1) to approximately 60 lb-ft (75 N.m). Using the near sided section of the rack assembly, turn the gear (item 2) to move the rack to obtain 1 visible tooth as shown in Figure 112 Rack & pinion adjustment or until the rack extends approximately 1-3/8" from the base.

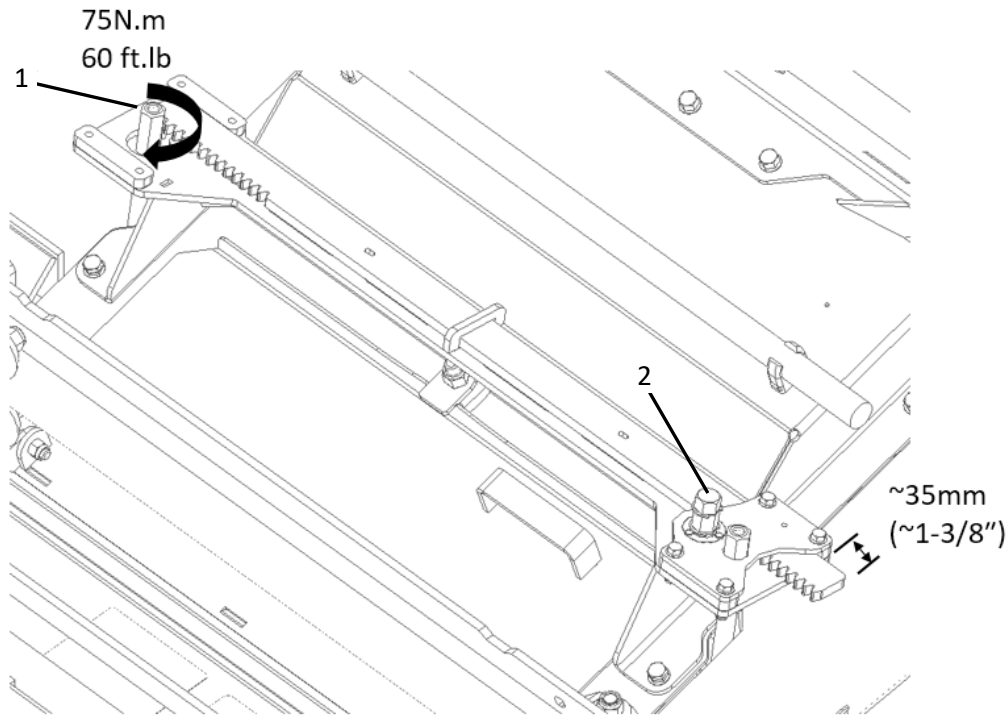

Figure 113 Positioning the rack and pinion

5. Reinstall the gear onto the locking rod (item 1) by indexing it until it best aligns with the rack.
6. Reinstall the top plate (item 3) using the same hardware (items 2). Tighten the elastic stop nuts just so the bolts are not loose in the assembly. Overtightening these will cause excess friction in the rack and pinion assembly. Apply a few drops of oil in the lubrication holes (item 4) and ensure the system operates smoothly. Ensure that at least 1 tooth is visible (as shown in Figure 112 Rack & pinion adjustment) after the locking rod (item 1 Figure 112 Rack & pinion adjustment) has been tightened completely.

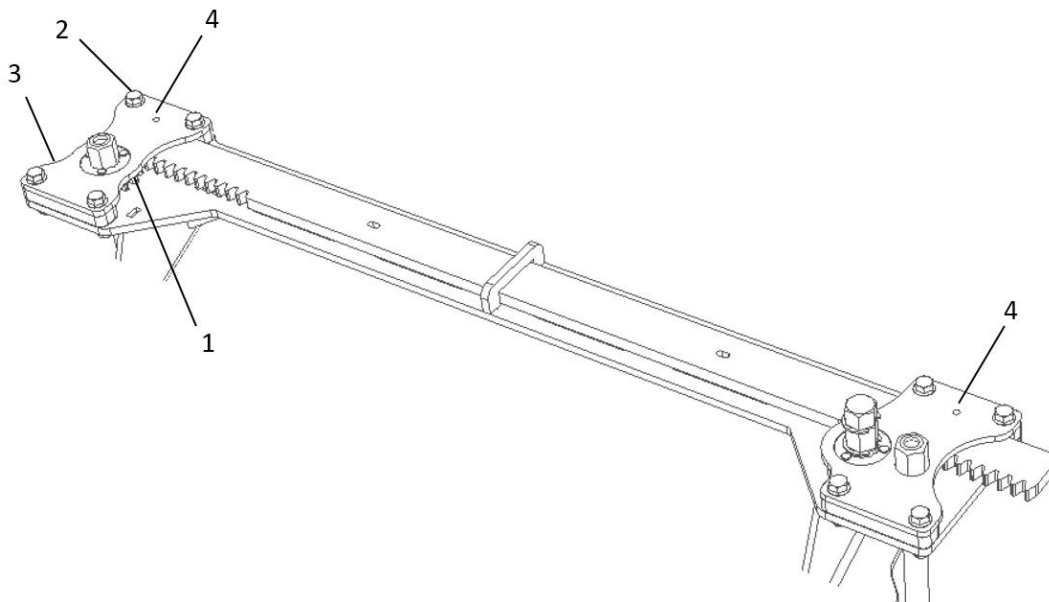

Figure 114 Reinstall the rack

MAINTENANCE & AJUSTEMENTS

CUTTERHEAD LINER REPLACEMENT

FIGURE 115

The bottom plate under the cutter head can be replaced by sliding it backwards.

1. Unbolt the bottom plate by removing the support (item 1), the two 3/8" X 3" lg carriage bolts (item 6) and 3/8" lock nuts (item 7).
2. Remove the half bottom plate (item 3) and the three bolts on each side (item 4).
3. Unbolt the two access doors (item 5) and remove the bolts. The upper processor roll must also be removed if necessary.
4. It is now possible to remove the bottom plate by sliding it under the cutter head.
5. Clean thoroughly before sliding in the new bottom plate.
6. Tighten the two 3/8" X 3" lg carriage bolts before tightening the three bolts on each side (item 4).

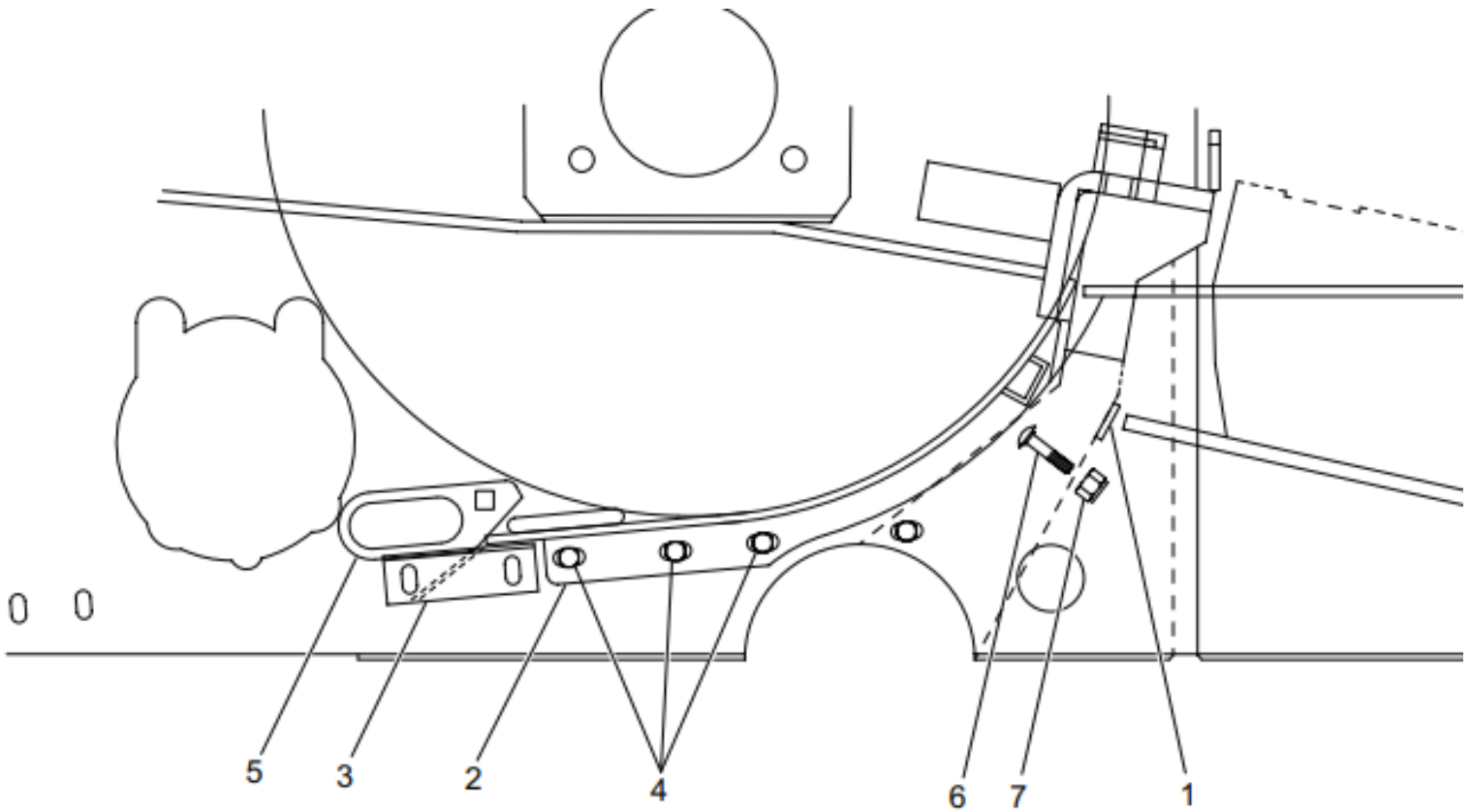

Figure 115 Cutterhead liner

MAINTENANCE & AJUSTEMENTS

PROCESSOR LINER ADJUSTMENT

FIGURE 116

Adjust the front half bottom plate (item 1): Loosen all 8 bolts (item 6) and leave a lengthwise clearance of 1/16" to 1/8" (1.5 to 3) between the front half bottom plate and the lower roll (item 3) as shown below.

NOTE: The front half bottom plate (item 1) must always be bolted under the cutter head bottom plate (item 4). Tighten all 8 bolts securely while retaining the even, lateral spacing between the lower roll and the bottom plate.

NOTE: Check deflector wear (item 7) and replace them if necessary. Worn deflectors will let corn leak between the end of the processor roll and the machine frame.

NOTE: A tall reflector is used on the left-hand side and a short one on the right-hand side (item 7).

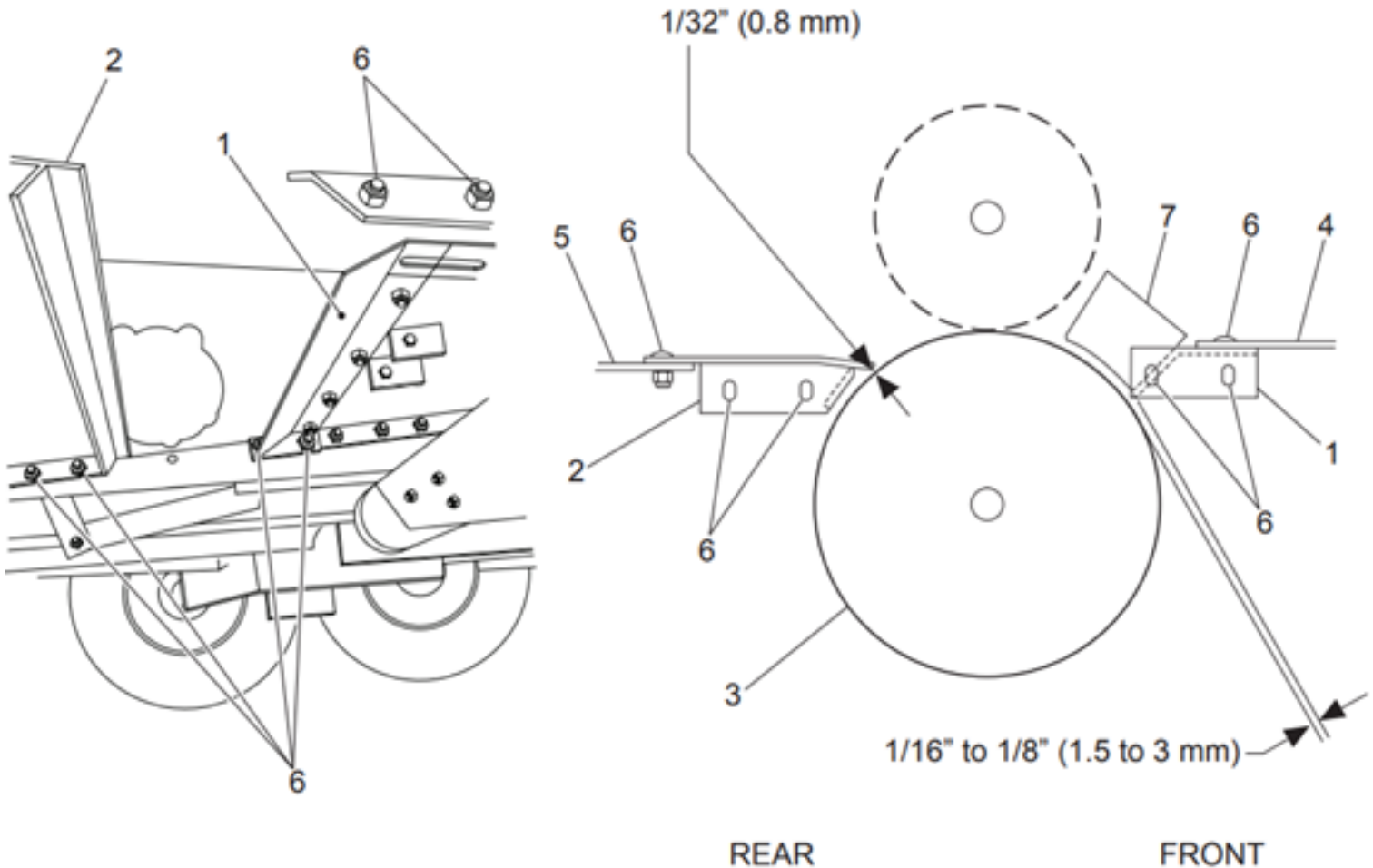

Figure 116 Processor plates adjustment

Adjust the rear half bottom plate (item 2): After installing the rear bottom plate and the adjustment bolt support bracket, adjust the distance between lower roll and the rear half bottom plate.

NOTE: The rear halfback (item 2) must always be bolted above the bottom of the accelerator (item 5). Tighten all the bolts.

NOTE: The lower Corn Processor roll must NEVER touch the rear half bottom plate. Use gauges with recommended thickness, as shown here.

MAINTENANCE & AJUSTEMENTS

1. Hand tighten the two bolts on each side (item 1).
2. Insert a 1/32" spacer (item 3) at each end of the roll, between the roll and the half bottom (item 2).
3. Using a vise grip clamp (item 5 - Figure 118 Processor roll adjustment), lock the half bottom and roll together. Tighten the two bolts on each side properly (item 1 - Figure 117 Processor roll adjustment)
4. Using the three 5/16" X 4 1/2" lg carriage bolts (item 4), adjust to 1/32" the gap between the roll and the half bottom, over the entire width.

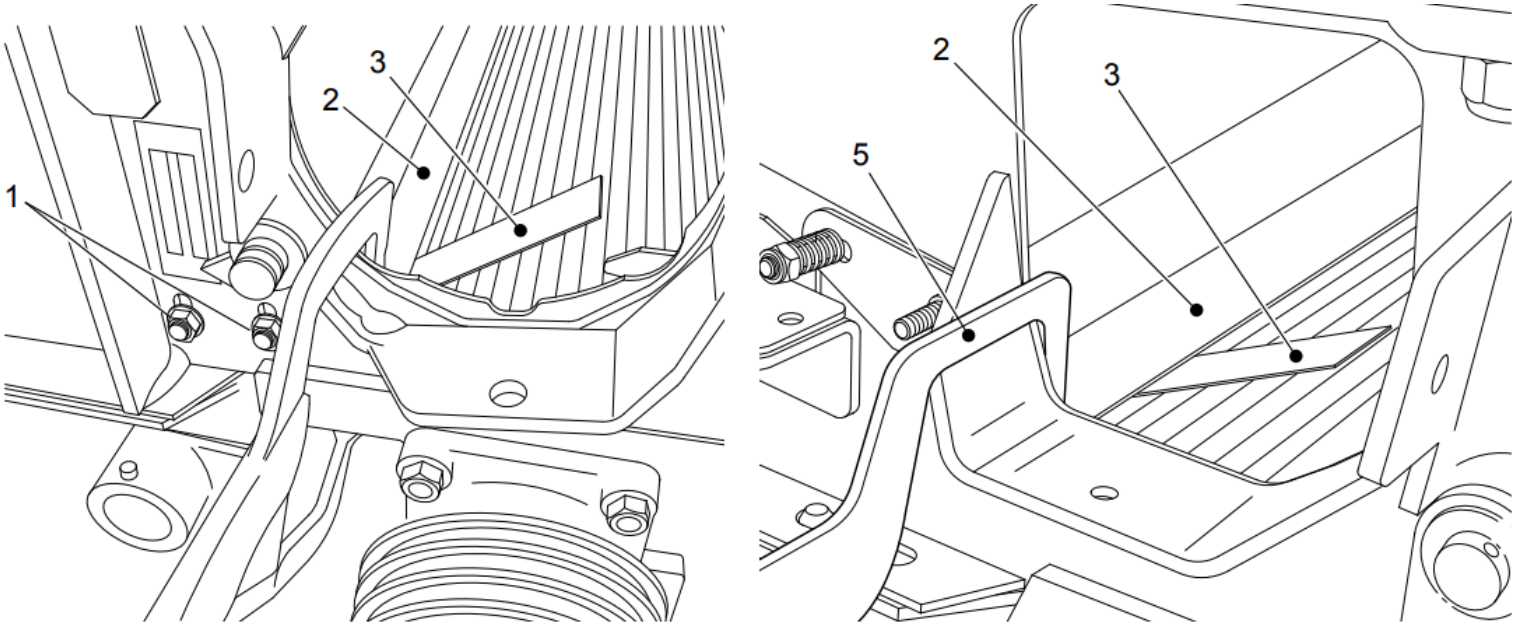

Figure 117 Processor roll adjustment

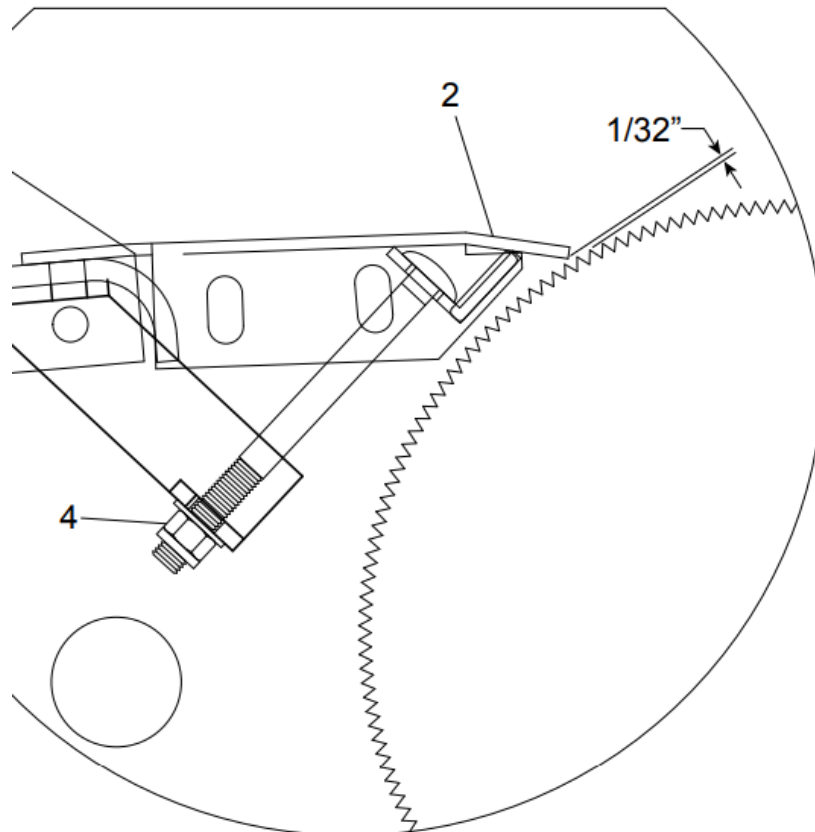

Figure 118 Processor roll adjustment

MAINTENANCE & AJUSTEMENTS

PROCESSOR MINIMUM GAP ADJUSTMENT

FIGURE 119

1. Loosen bolts on the levelling plate (item 7).
2. Use a 1/16" (1.5) gauge between the 6" top roll and 10" bottom roll.
3. There are 2 adjustment bolts. One on each side of the processor rolls. The head of these bolts (item 2) rest against the underneath of the support flanges (item 3). Loosen the 2 nuts on each bolt. While holding the head of the bolt in place, turn the adjuster nut (on the same side as the head of the bolt). This will raise or lower the 6" roller assembly. Adjust both sides of the roller assembly until a gap of 1/32" to 1/16" (0.8 to 1.5) between the 6" and 10" corn processor roll is achieved. While holding the adjuster nut, tighten the lower nut until the adjuster bolt is locked in place. Confirm that the pointer is indicating "ZERO" on both decals (item 6). If the right-hand and/or left-hand decals do not match or do not point to "ZERO", apply new decals to ensure "ZERO" is accurately indicated on both sides.
4. Rotate both top and bottom rolls to make sure there is a 1/32" to 1/16" clearance all around the rolls.
5. Tighten all levelling plate bolts (item 7) properly.
6. Install the zero-setting seal (item 8) using cable ties.

NOTE: Make sure corn processor rolls NEVER touch.

NOTE: Engage tractor PTO and make sure nothing touches touching at low and then at high speed.

NOTE: Readjust the zero position after replacing a high-speed bearing or either processor rolls.

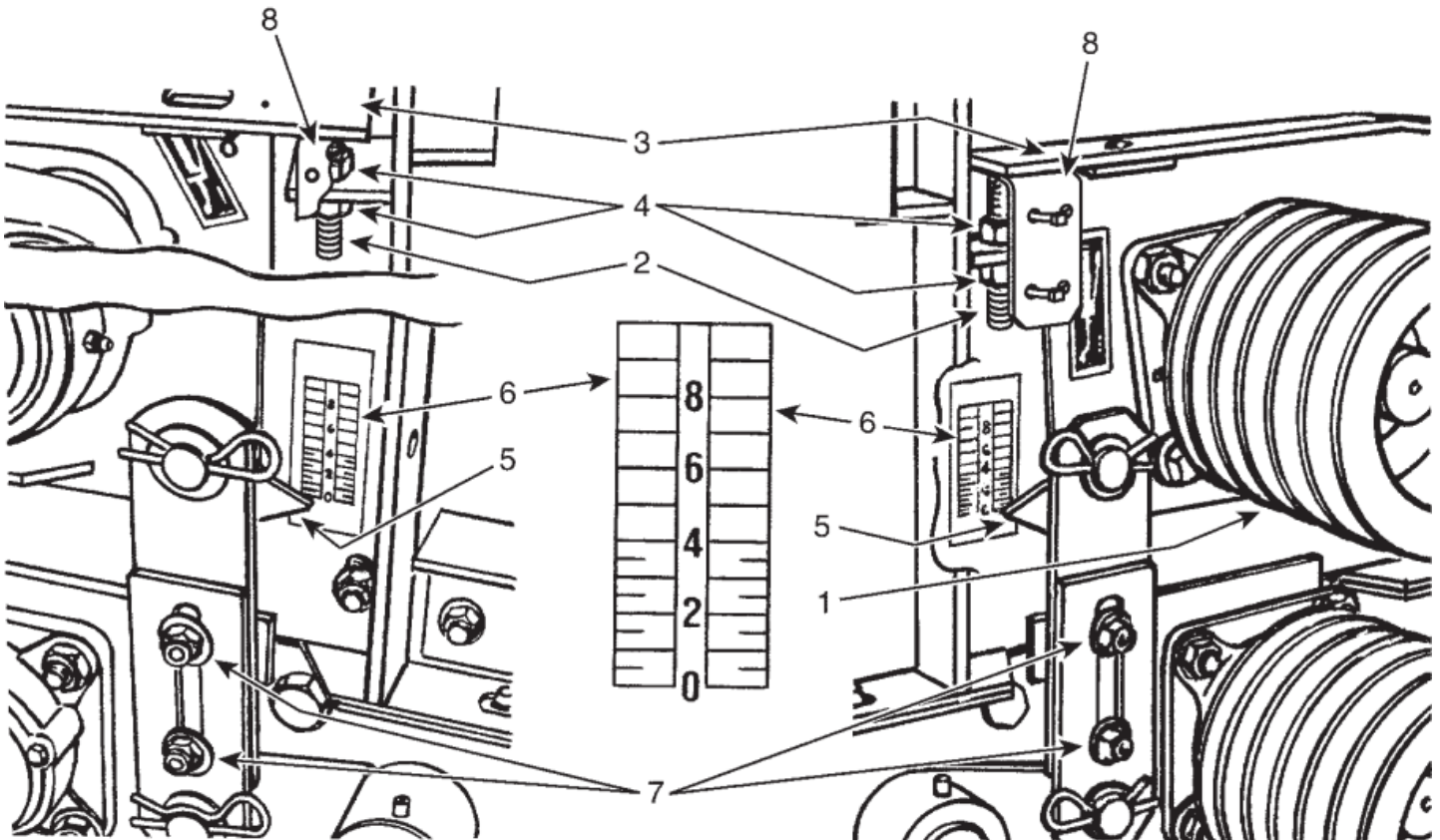

Figure 119 Minimum processor roll clearance adjustment

MAINTENANCE & AJUSTEMENTS

ACCELERATOR LINER REPLACEMENT

FIGURE 120, FIGURE 121, FIGURE 122

1. Remove the rear guards.
2. Remove the 6" upper processor roll (if installed) from the forage harvester (see CONFIGURING FOR CORN HARVEST SETUP).
3. Remove the lower half bottom plate of the processor roll (9 bolts).
4. Remove all bolts holding the accelerator bottom plate (9 bolts on each side and five bolts on the discharge housing).
5. Unbolt the two bearings (item 1) from the accelerator shaft and remove the two support plates (item 2) (one thin and one thick) on each side.

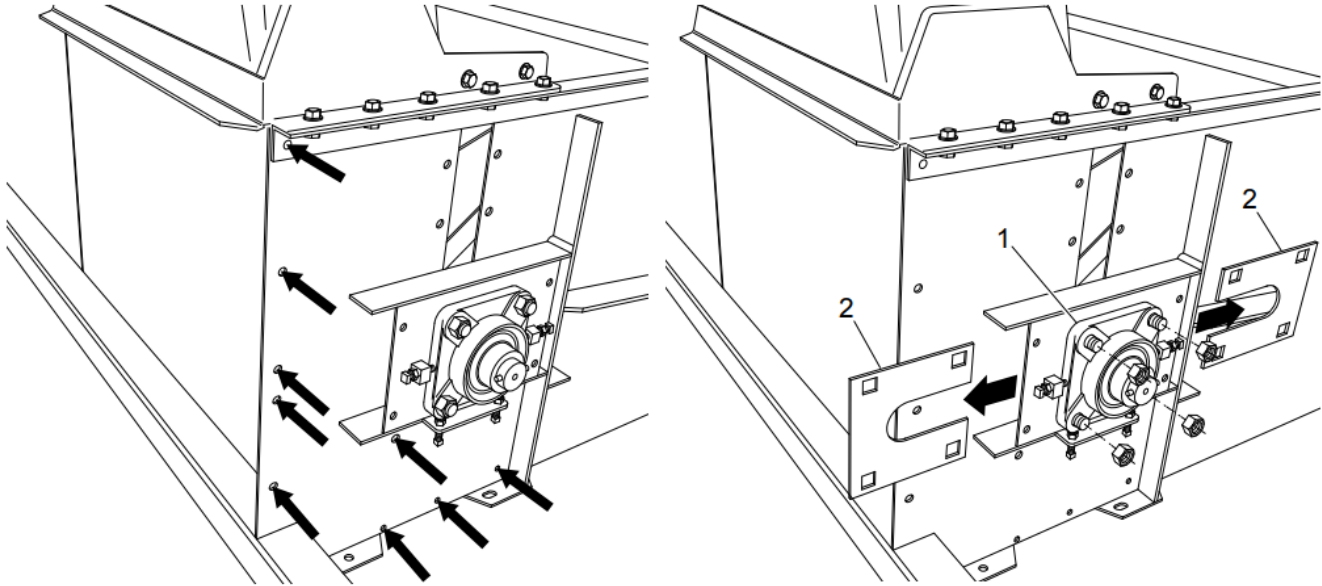

Figure 120 Blower liner removal

6. Unlock and unscrew the adjustment bolt (item 3) on the front side of each bearing.
7. Lift the accelerator assembly on both sides simultaneously, as shown, with two metal bars (item 4) and two pieces of wood (item 4 & 5).

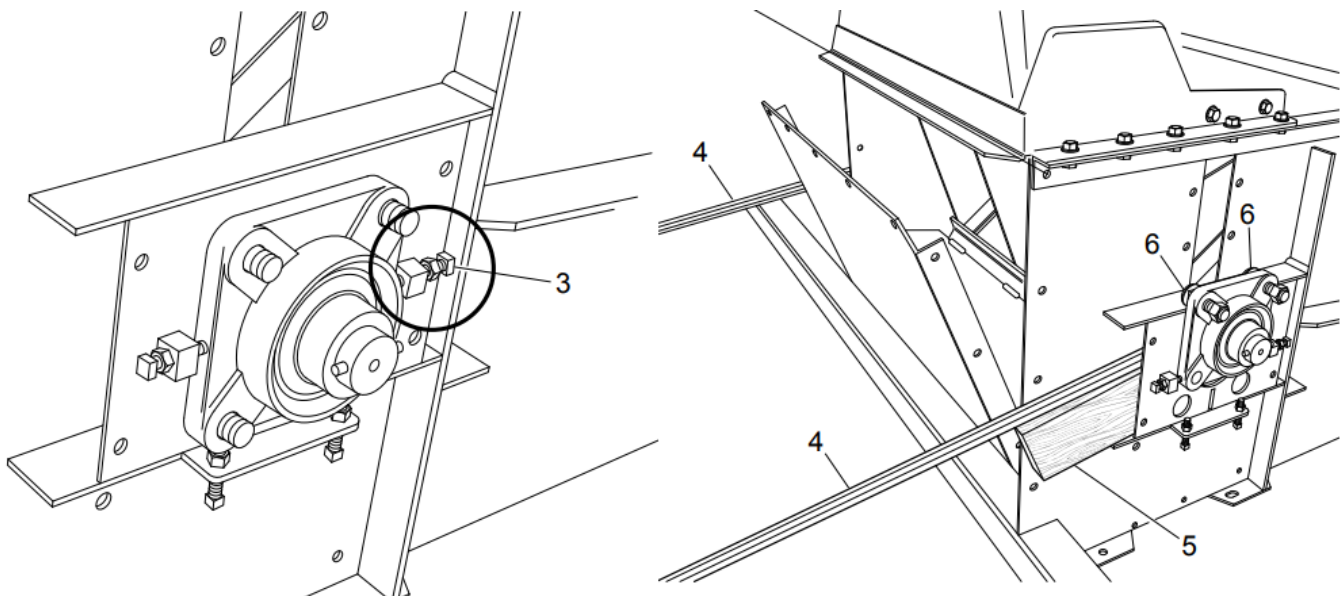

Figure 121 Accelerator replacement

MAINTENANCE & ADJUSTMENTS

- Remove the 2 bottom bolts (item 6) from both of the bearing assemblies, on both sides. Leave the two top bolts on each side (in the top holes of the bearings) in order to keep the accelerator assembly in the raised position.
- Remove the accelerator liner and replace with the new one.
- Secure bottom plate with the nine bolts on each side and five bolts on the discharge housing (). Firmly tighten all bolts. Do not forget the guard support bracket on each side.
- Install the lower roll half bottom plate of the processor roll with the adjustment support bracket and nine bolts. Firmly tighten all bolts.
- Slide accelerator assembly down back to its operating position. Secure both bearings in place with four bolts and the two support plates (one thin and one thick), on each side.
- Proceed with the accelerator adjustment (Figure 122 Accelerator adjustment). Firmly tighten all bearing and adjuster bolts and nuts.
- Reinstall all guards.

ACCELERATOR ADJUSTMENT

FIGURE 122



DANGER: Stop the PTO and switch off the tractor engine before adjusting the accelerator.



WARNING: When working inside the cutting chamber, block the cutter head with a piece of wood in order to prevent it from rotating (see Figure 122 Accelerator adjustment).

When the forage harvester has been in use for a long period of time, the extremity of the accelerator's four blades will be worn, even if they are made from hardened steel. The condition of the blades should be verified every **100 hours** of operation. **The accelerator throwing force is directly related to the implementation of the following procedure:**

- Open the top cover located between the spout base and the cutter head. Lock it open with the spring-loaded latch.
- Loosen the four bolts (item 3) on the bearing, on both sides.

NOTE: Check the condition of the accelerator's bottom plate (item 5); replace it if it is damaged or punctured. Check the condition of the blades (item 6); replace them if they are bent or very worn (rounded corners).

- Using the set screws (item 4), adjust the accelerator to a clearance of 0.040" to 0.045" (1.02 to 1.14) between the edge of the blade (item 6) and bottom plate of the accelerator (item 5) at the "6H" (6 o'clock) position (see Figure 192). While maintaining the 6 o'clock clearance, adjust the accelerator to a clearance of 0.090" to 0.120" (2.5 to 3) between the edge of a blade and the bottom plate of the accelerator at "8H" (8 o'clock) position. Return to the 6 o'clock and reverify the clearance. Continue in this manner until both the 6 and 8 o'clock positions are correct. This theory behind these 2 adjustments is to obtain a clearance that is tight at the front of the accelerator contour and increases as the accelerator approaches the rear of the accelerator contour.

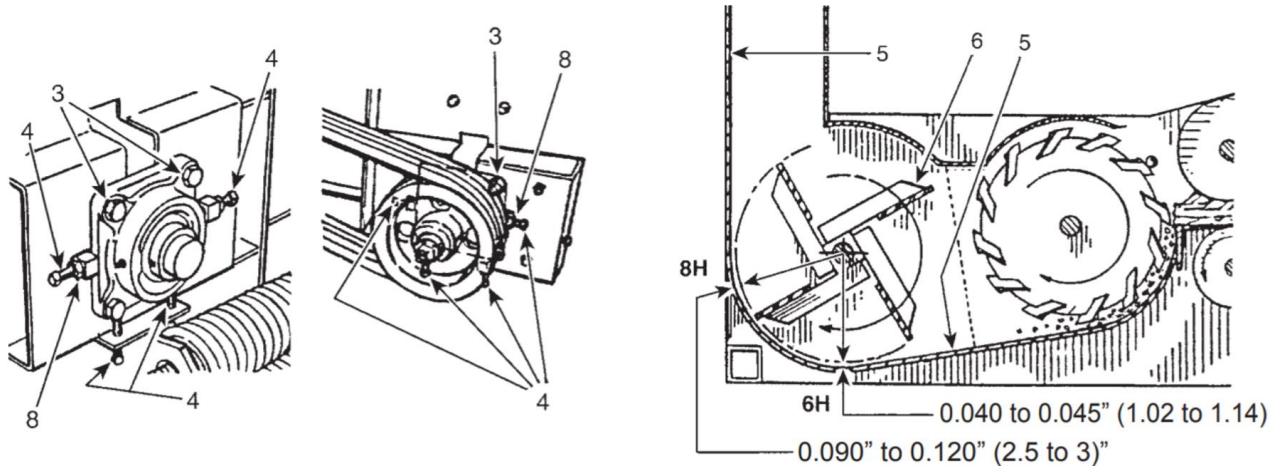

Figure 122 Accelerator adjustment

MAINTENANCE & ADJUSTMENTS

NOTE: Because of particular operating conditions and the power of the tractor, the accelerator on the forage harvester may become noisy. Inspect all the surfaces throughout the accelerator chamber for dried material or defective surfaces. If the noise continues, progressively increase the clearance at 6H (6 o'clock) in 0.015" (0.4) increments until noise is no longer noticeable. However, a clearance that is too large may reduce the throwing capacity of the machine.

NOTE: One 360° turn of the screw is equal to a 1/16" (1.5) clearance.

4. Re-tighten bolts (item 3) on both sides then tighten the screws (item 4) and lock them in place with a nut (item 8). Once all these adjustments and/or replacements have been fully completed, rotate the accelerator manually and check for possible friction.
5. Put the cover and guards back in place.

NOTE: All maintenance work described in this chapter is entirely the responsibility of the owner and/ or operator.

ACCELERATOR PADDLE REPLACEMENT AND BALANCING

FIGURE 123

NOTE: If blades are replaced, ensure the accelerator assembly is first moved away from the bottom plate. The new blades will be longer than the blades being replaced due to wear. Since the accelerator assembly is subjected to a high centrifugal force, ensure blades are always installed the outward most position as shown on the figure.

NOTE: Blade kit contains a set of four balanced blades

To check accelerator balance:

1. Remove the belts from the accelerator.
2. Remove all residual material from inside the accelerator chamber.
3. Rotate the accelerator by hand and hold a pair of blades perfectly horizontal, as shown in Figure 123 Accelerator paddle adjustment.
4. Release the accelerator. If the accelerator stays still, these two blades are well balanced. If the accelerator starts rotating, this means 1 blade is heavier than the opposite blade (see Figure 123 Accelerator paddle adjustment). The blade that rises is the blade that will require additional weight. Weight must be added to the blade's central arm. Special holes are drilled in the blade arms in order to add nuts and bolts as the counterweight.

NOTE: Secure the weight to the middle blade arms.

5. Repeat steps 3 and 4 with both sets of blades until the accelerator assembly is balanced.

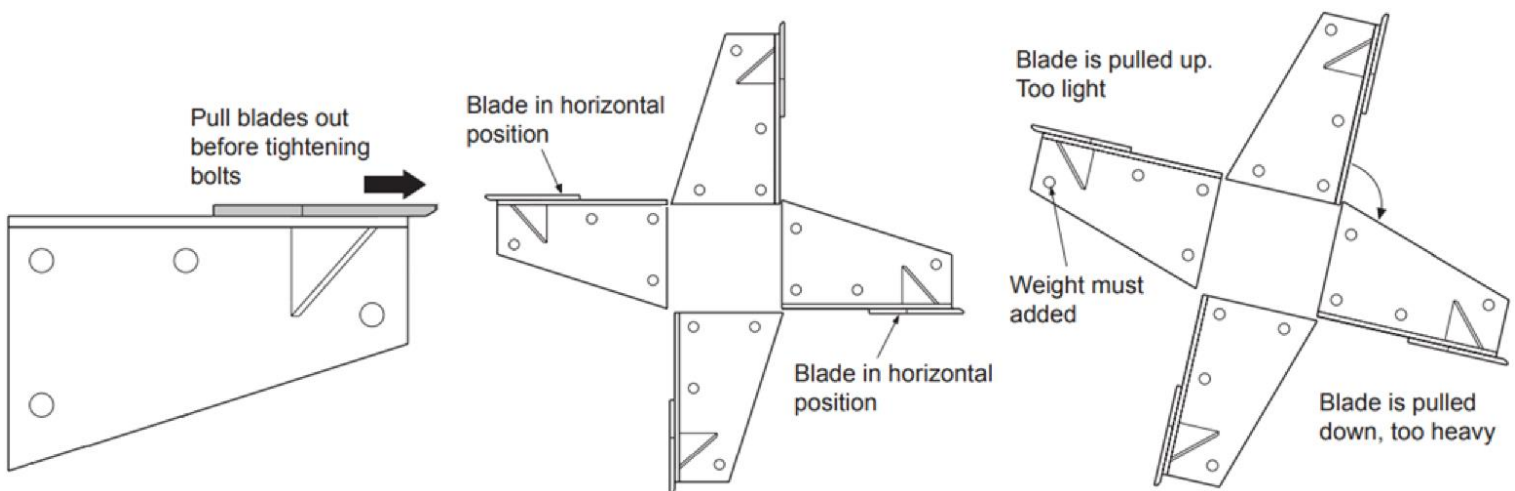

Figure 123 Accelerator paddle adjustment

MAINTENANCE & AJUSTEMENTS

SPOUT ROTATION MOTOR AND GEAR ADJUSTMENT

FIGURE 124, FIGURE 125

To ensure optimal durability of the motor and the chute rotation gear, adjust as necessary.

1. Rotate spout to the left-hand side of the machine.
2. Remove top shield (item 1) to access spout motor gear.
3. Loosen all set screws (item 3) and lock nuts (item 2).

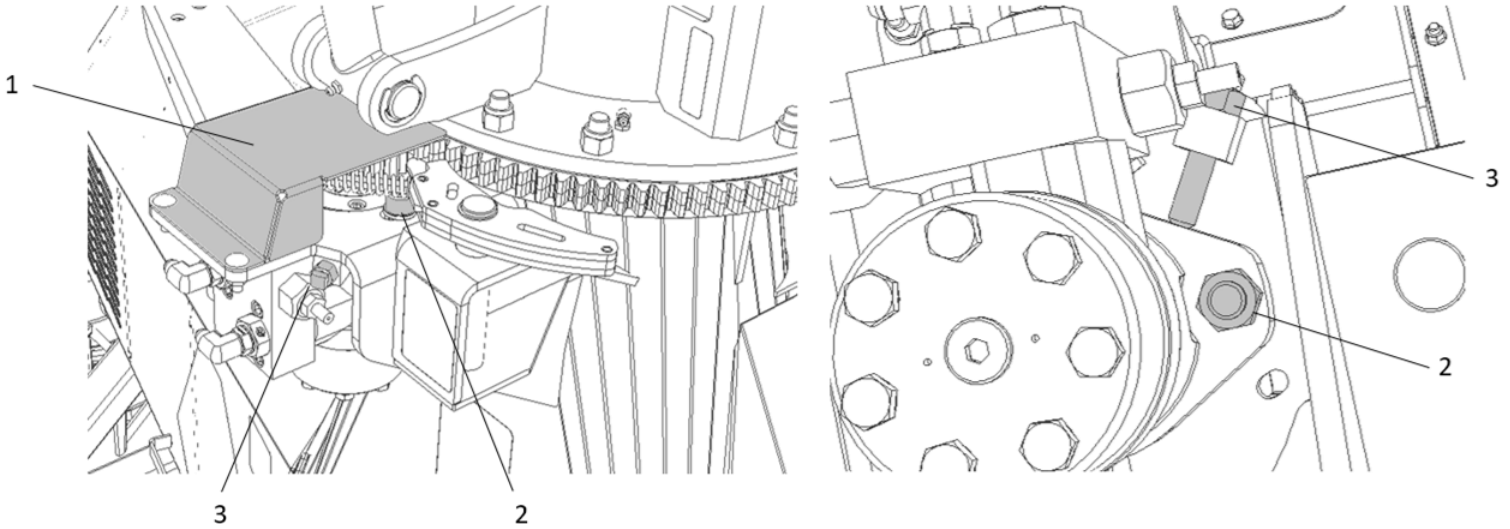

Figure 124 Spout rotation motor adjustment

4. Adjust the clearance between the pinion gear and the ring gear by turning set screw (item 3). Allow a play of 0.1 mm (0.004 in.) between the teeth of the pinion gear and the crown (item 5)

IMPORTANT: Do not apply lubricant between the pinion gear and the ring gear.

5. Tighten lock nuts (item 2).
6. Lock the adjuster screw in place with the lock nut (item 3).

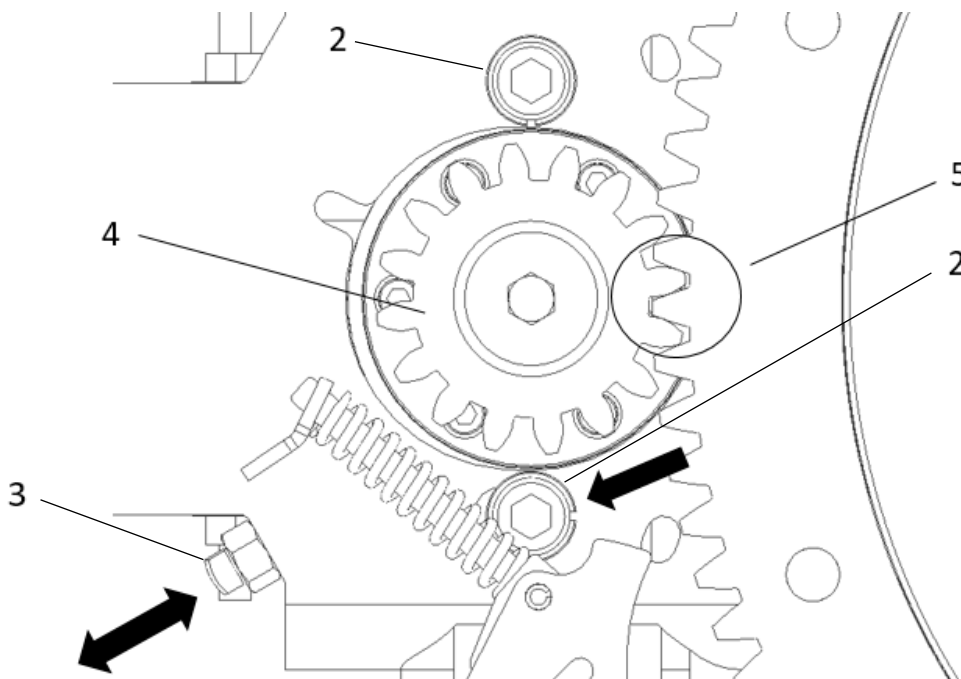

Figure 125 Spout motor adjustment

MAINTENANCE & AJUSTEMENTS

SPOUT CYLINDER TRAVEL SENSOR ADJUSTMENT

FIGURE 126

Adjusting the cylinder sensor to maintain travel on the drop cylinder is essential to ensuring proper suspension operation, especially with the Stinger chute extension, during transport mode (item 4).

IMPORTANT: Operating the chute with the Stinger configuration without proper cylinder clearance can damage the structure of the forage harvester or the chute itself.

To adjust the sensor:

1. Disconnect the sensor connection (item 1) and lower the chute to fully contract the cylinder.
2. Raise the magnetic target (item 3) to its lowest position on the support.
3. Adjust the sensor to obtain a clearance of 2-3mm (~ 1/8") between the sensor tip and the target.
4. Rotate the sensor about 15deg counter clockwise from vertical and tighten the sensor bolt (item 5). Reconnect the sensor.
5. Lift the chute completely and lower it completely. The sensor must interrupt the lower range of the descent to retain 20-25mm of travel remaining on the drop cylinder shaft (item 4). Continue to adjust the position of the sensor to obtain the required travel after lifting and lowering the chute.

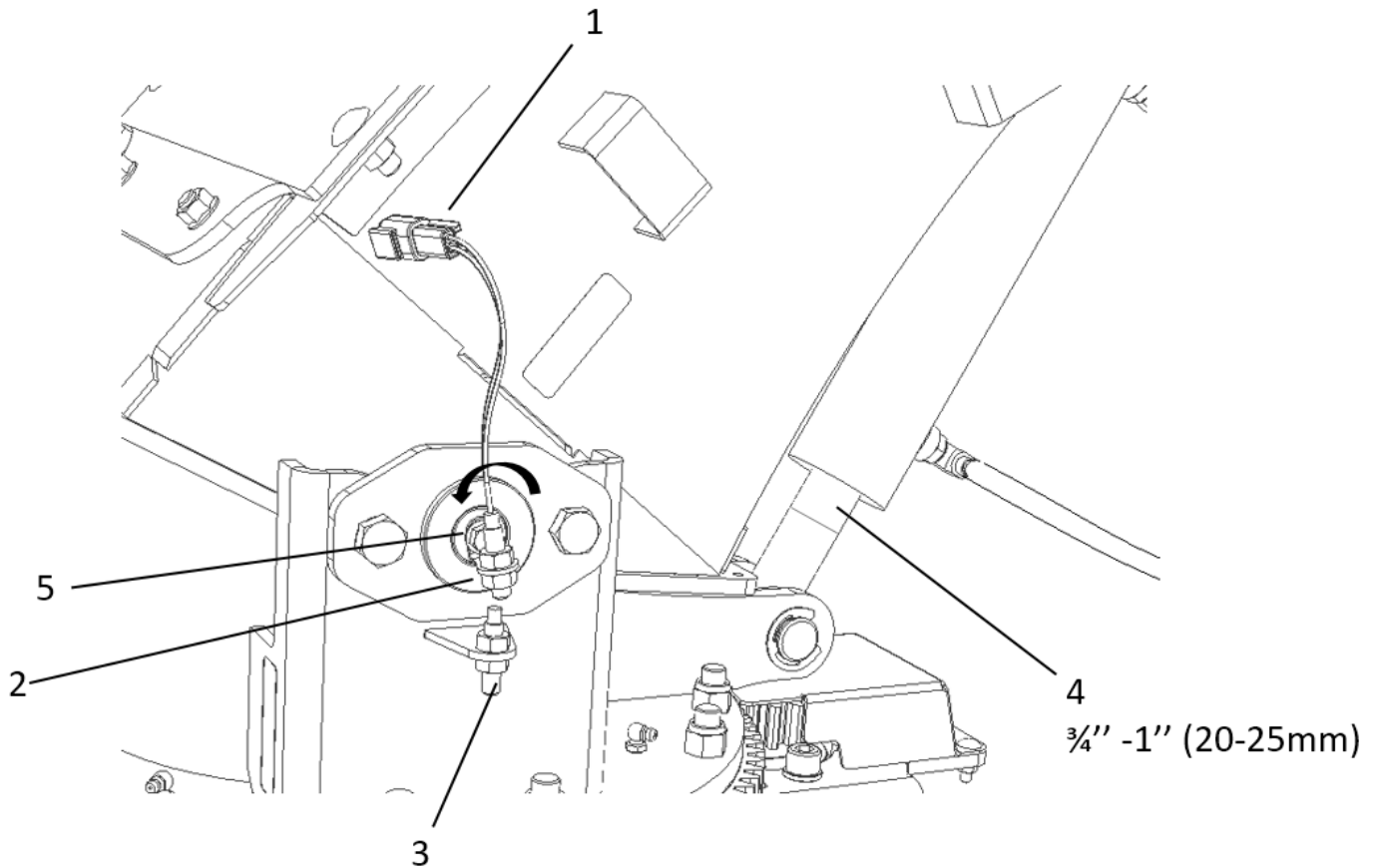

Figure 126 Spout limit switch adjustment

MAINTENANCE & AJUSTEMENTS

SPOUT LINER REPLACEMENT

FIGURE 127

When the main wear strip (item 1) or that of the "Stinger" extension is worn or punctured:

1. Lower the chute completely.
2. Unbolt the wear plate (item 3), the hoses while leaving the support remain in place.
3. Using a scraper, remove excess silicone sealant from the structure of the chute (item 3).
4. Apply thin line of clear silicone sealer to prevent leakage. Let it set up partially.
5. Install the new plate and tighten the bolts (item 2).
6. Reconnect all hoses and cables.

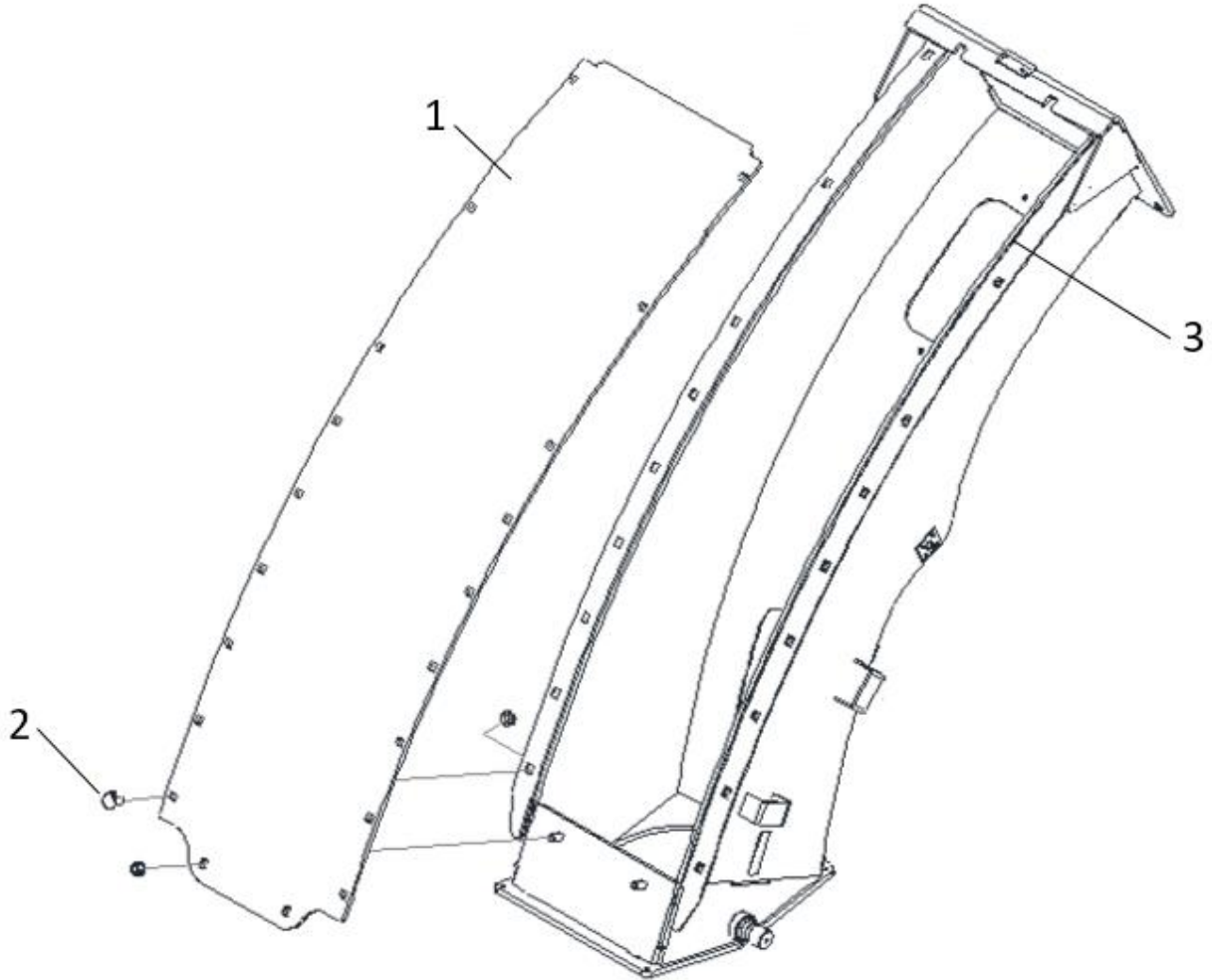

Figure 127 Spout liner replacement

MAINTENANCE & AJUSTEMENTS

FEED ROLL SPRING TENSION

FIGURE 128

Both upper feed rolls are under tension and maintain the ability to open and close to a controlled extent. Their vertical motion is limited by four springs (item 1). The vertical displacement of these rolls is interdependent and controlled by stabilizing bars (item 2).

There are two springs on either side of the feeding inlet. Their purpose is to compress the crop passing through the feed rolls. To preload the springs, adjust the space between the bottom of the eyebolt head (item 3) and the support plate (item 4) to approximately 1.5mm (1/16in). Do this by adjusting the lock nut (item 5) while preventing the eyebolt from rotating.

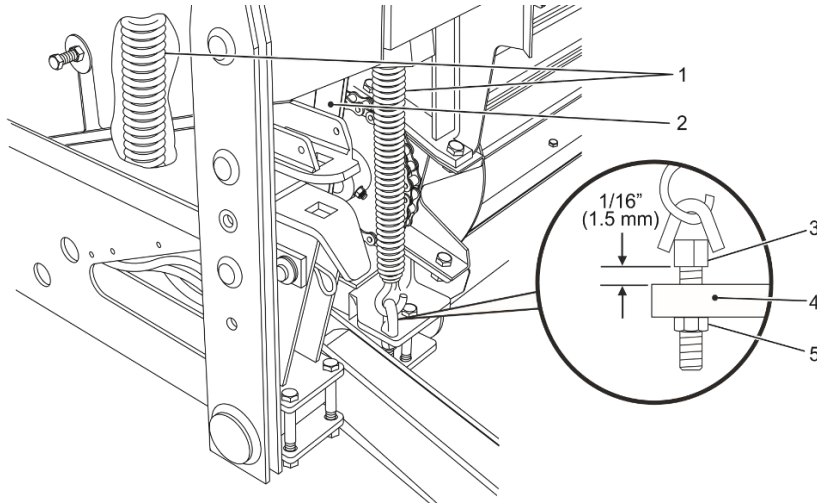

Figure 128 Feed rolls compression springs

HARVESTING UNDER SPECIAL CONDITIONS

FIGURE 129

For certain types of crops or conditions where the crop is very slippery, like straw harvesting or short wet hay, the spring tension can be reduced.

- Loosen the front springs (item 1) by loosening the eyebolt nut (item 5, FIGURE 128 Feed rolls compression springs).
- If clogging still occurs, loosen the rear springs (item 3, FIGURE 129 Adjustment for special conditions) as well. It may also be necessary to completely remove the springs.

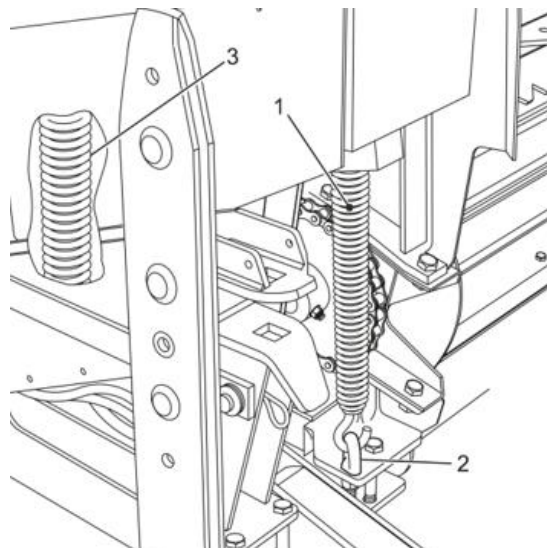

Figure 129 Adjustment for special conditions

MAINTENANCE & AJUSTEMENTS

FEED ROLLS CHAIN TENSION

FIGURE 130 - FIGURE 131

To adjust the tension of the top feed roll chain (item 1), loosen the bolts (item 2) completely and add/remove spacers (item 3) as needed from beneath the tensioner plate (item 4) to obtain the required tension. Make sure the tensioner is centered with the chain rollers (item 5). Place any unused spacers on top of the tensioner plate for future use. Tighten the nuts properly.

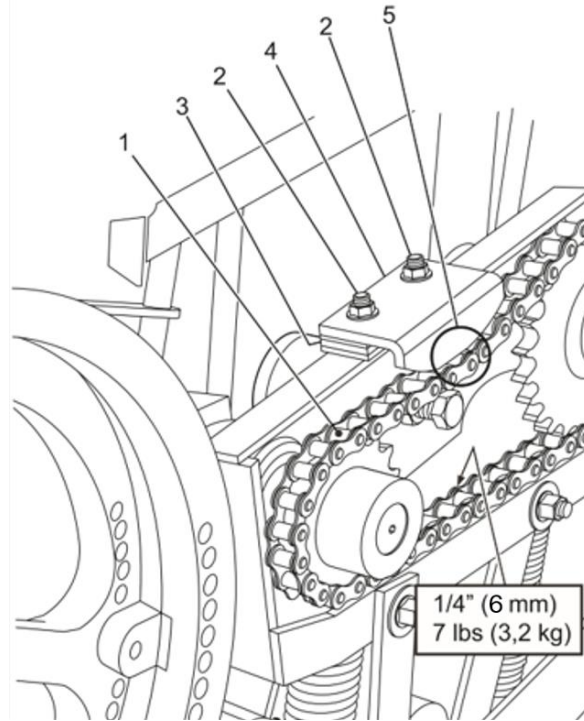

Figure 130 Top feed roll chain tension

To adjust the bottom feed roll chain (item 1) tension, loosen both nuts (item 2), and then push the tensioner (item 3) upwards until the proper tension is set before tightening the bolts. Ensure the tensioner plate is horizontal about the holes in the plate (bolted through corresponding holes on both rows). Do not install through random holes. Make sure the tensioner plate is centered on the chain rollers (item 4) by adjusting the number of shims (item 5).

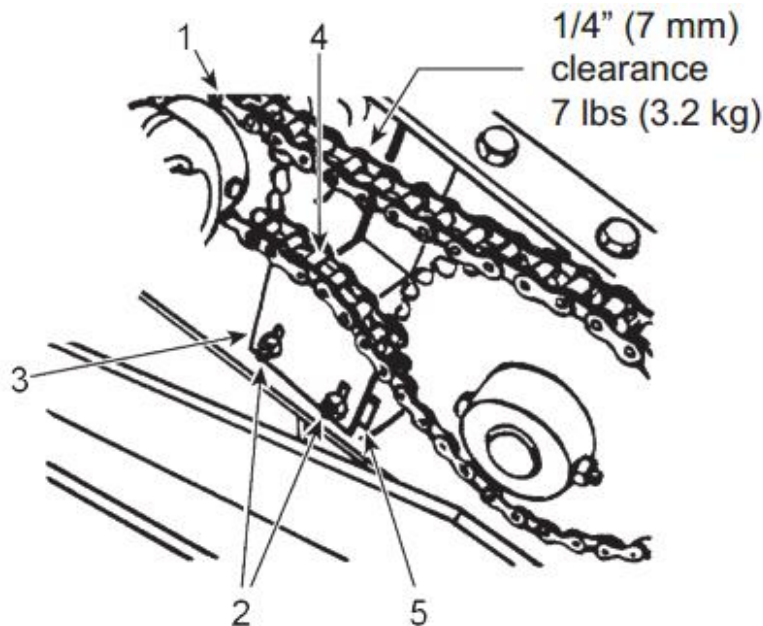

Figure 131 Lower feed rolls chain tension

MAINTENANCE & AJUSTEMENTS

TRANSMISSION BELT TENSION

FIGURE 132

The 4-banded belt (item 1) driving the main transmission is tensioned by a floating tensioner pulley arm (item 2). To maintain full power transfer to the transmission, the tensioner pulley arm spring should be adjusted to obtain a gap of 1,5 to 2,5 mm (1/16 - 3/32 in) between the coils.

This gap is maintained by adjusting the lock nut (item 3) while preventing the eyebolt from rotating. The stroke limiter bolt (item 4) must be adjusted to maintain a gap of at least 3mm (1/8 in) between the tensioner pulley arm and the tip of the stroke limiter bolt.

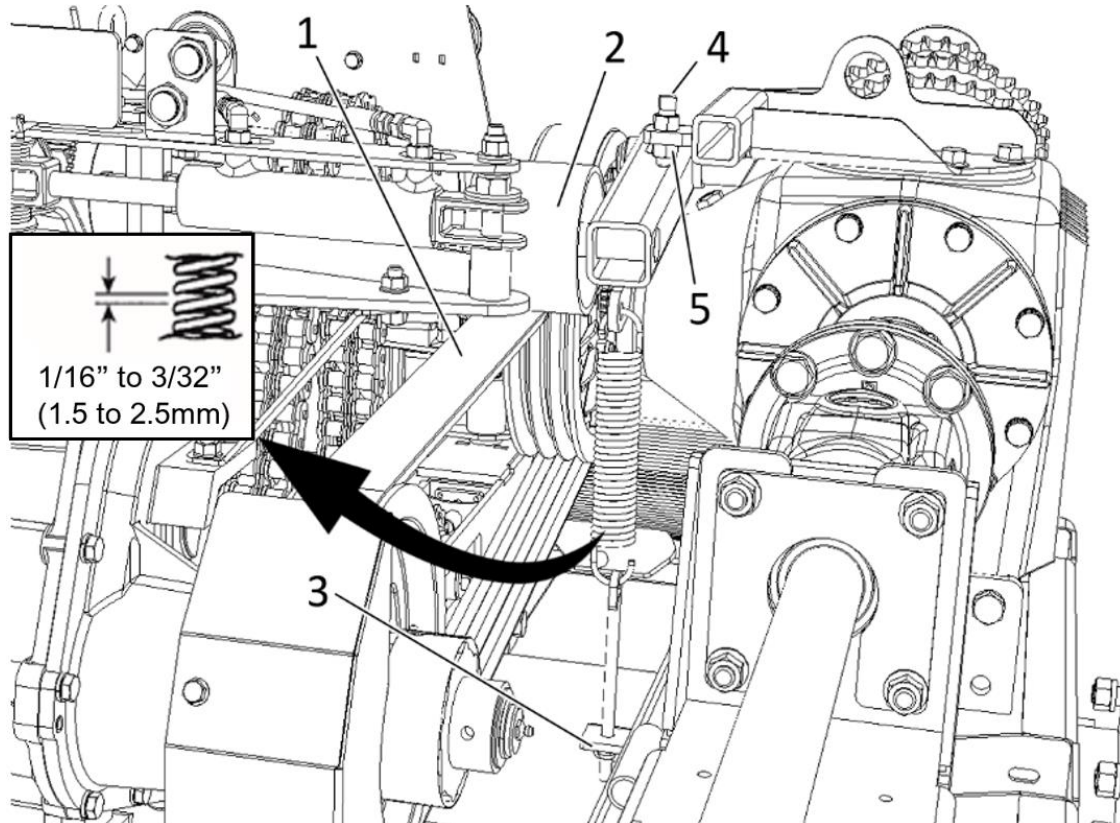

Figure 132 Main transmission belts

MAINTENANCE & AJUSTEMENTS

ACCELERATOR BELT TENSION

FIGURE 133

The 4-banded belt (item 1) of the accelerator is driven by the pulley on the cutter head shaft. Its tension is adjusted with the spring (item 2):



WARNING: Always make sure all rotating components have stopped before servicing the harvester.

1. Loosen the locking nut (item 4).
2. Adjust the spring rod (item 3) until there is a 1.5 to 2.5mm (1/16-3/32in) gap between the coils.
3. Tighten the locking nut (item 4).

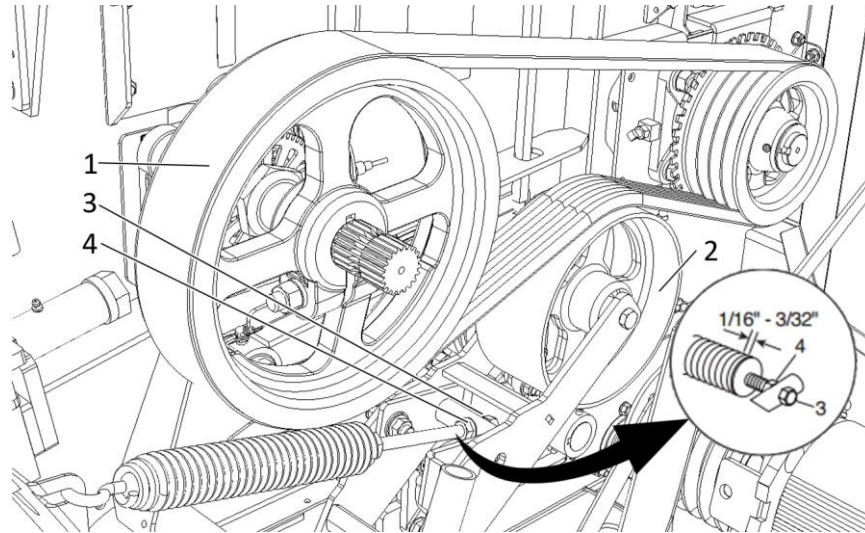

Figure 133 Accelerator belt tension

PROCESSOR BELTS TENSION

FIGURE 134

The tension is maintained through the tension idler (item 4). Tighten the belts (item 5) by turning the (right-hand side) rod (item 2) of the tension spring (item 3) with the provided square head handle (item 1) to obtain a gap between the coils of 1.5 mm to 2.5 mm (1/8 - 3/32in). For higher demanding conditions or with a high horsepower tractor, increase this tension to avoid slippage and belt failure.

NOTE: During the first few hours of use, check the tension regularly to compensate for initial stretching of the 4 banded belts. Stretching may equate to approximately 1" to 2" (2.5 to 5 cm).

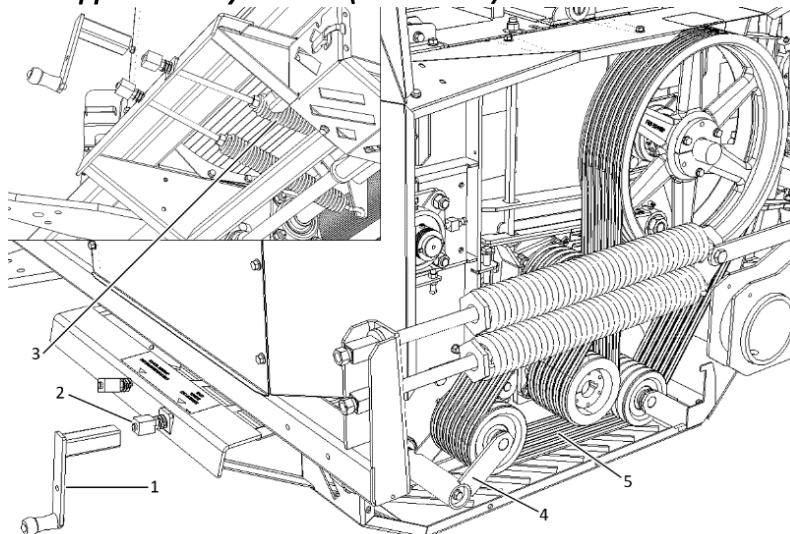

Figure 134 Corn processor belt tension adjustment

HEADER LIFT CYLINDER ADJUSTMENT

FIGURE 135

When the header is lifted to the maximum, it should not make contact with the forage harvester. If there is contact, adjust the length of the cylinder by adjusting the position of the attachment link.

NOTE: Always position the cylinder locking pin (item 5) upwards. Installed downwards, it can interfere with the lifting lever and break the cylinder rod and cause the harvesting tool to fall.

NOTE: Take precaution to not damage the cylinder shaft during adjustment as this will cause the shaft seal to leak.

1. Remove the pin (item 2) and the yoke of the jack (item 1).
2. Loosen the clamp bolt (item 5) and lift the cylinder. Turn the yoke to shorten or lengthen the cylinder stroke.
3. Reinstall the cylinder pin.



WARNING: Never work under an unsecured harvesting tool.

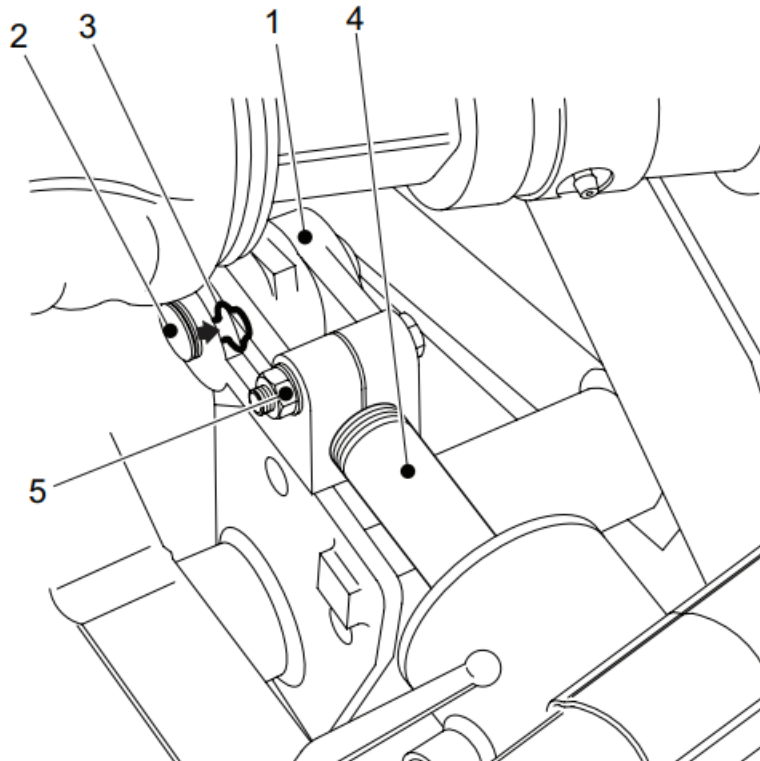

Figure 135 Header cylinder adjustment

MAINTENANCE & AJUSTEMENTS

STONE CARRIAGE ADJUSTMENT

To ensure precision when sharpening, all wheels must be properly seated on the roller shafts. Make adjustments so that all the wheels roll when operating the carriage. Any wheels that do not turn during sharpening must be adjusted to prevent vibrations.

1. Loosen the elastic jam nut (items 1) on any wheel that requires adjustment.
2. Adjust the nuts (item 2) of any wheels that was not spinning during the sharpening process until the wheel is in contact with the roller shaft. Do NOT apply high torque on these nuts. The wheels must roll smoothly of the shafts.
3. Holding the nut (item 2) in place, tighten the elastic jam nut to lock the wheel securely in place. Repeat for any wheel requiring adjustment.
4. Close guard (item 11).
5. Adjust the height of the stone (item 4) by pulling or pushing on the carriage (item 11) until the gear make firm contact with the spring-loaded flat bar (item 14). See
6. for more detail.

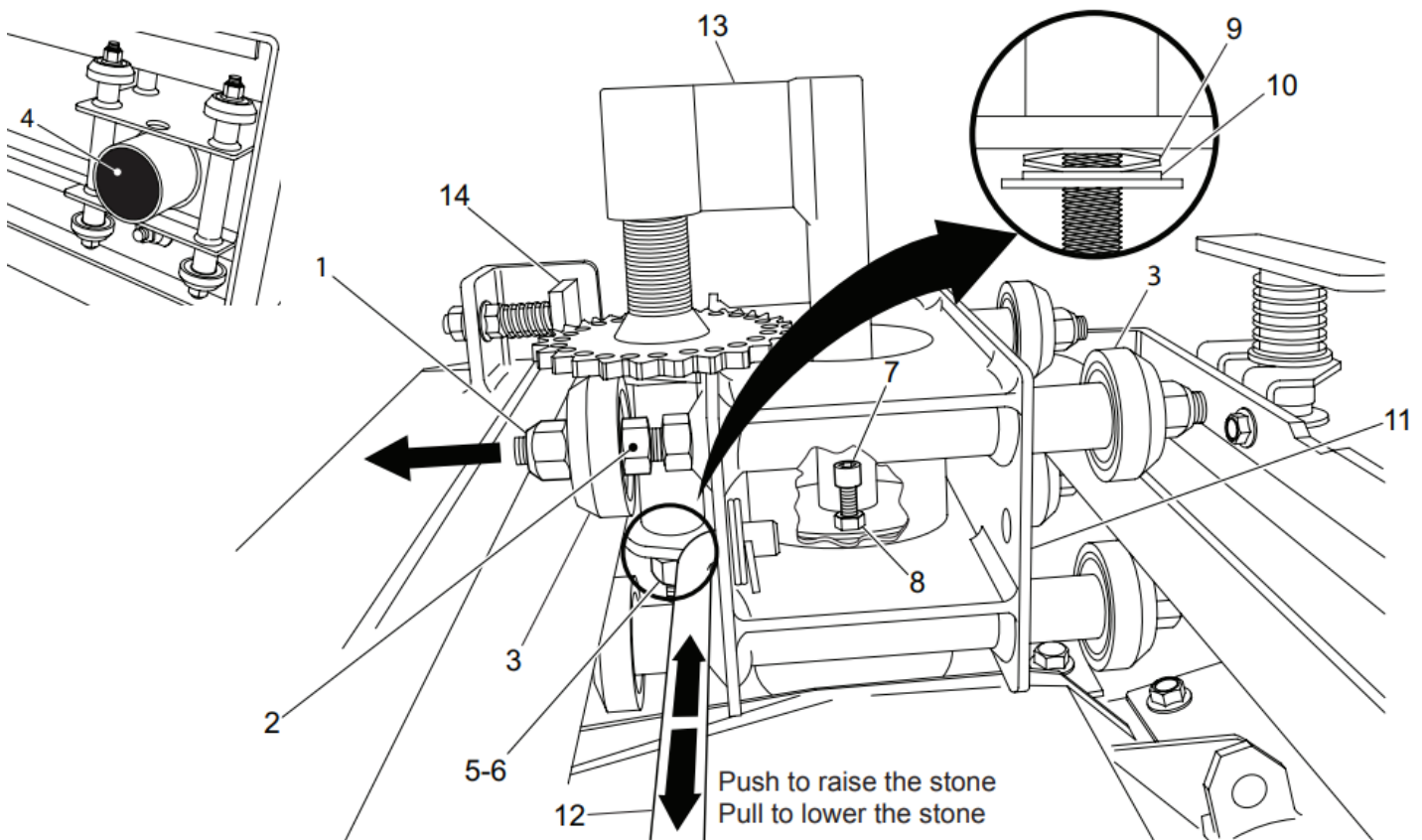

Figure 136 Stone carriage adjustment

MAINTENANCE & AJUSTEMENTS

SHARPENING STONE REPLACEMENT

FIGURE 136

1. Remove the elastic jam nut (item 5), the flat washer (item 6) and the spring washer (item 9).
2. Pull up the adjusting arm (item 13) and the stone assembly.
3. Loosen the two nuts (item 8) and the two set screws (item 7).
4. Unscrew the worn stone (item 4) to remove it.
5. Install the new stone to the support, tighten the set screws (item 7) and lock them with the nuts (item 8).
6. Lower the assembly to its original position, making sure the spring washers (item 9) and the flat washers (item 10) are as shown below.
7. Tighten the plastic stop nut (item 5) until the proper tension is obtained. Make sure the automatic ratchet system is working properly and all the wheels are in contact with the roller shafts.

SHARPENER FRAME ADJUSTMENT

FIGURE 137

The proper frame adjustment must be checked once a year to ensure a precise sharpening. to adjust:

1. Loosen the 5/8" nut (item 1).
2. Tighten the 5/8" X 2" lg flat stove bolt (item 2).
3. Eliminate most of the backlash between the support bracket (item 3) and the pivot (item 4) while making sure the frame is free to pivot.
4. Tighten the 5/8" nut back (item 1) while keeping the bolt (item 2) fixed.
5. Carry out the same procedure for the other pivot.
6. Lubricate and make sure frame pivots freely.

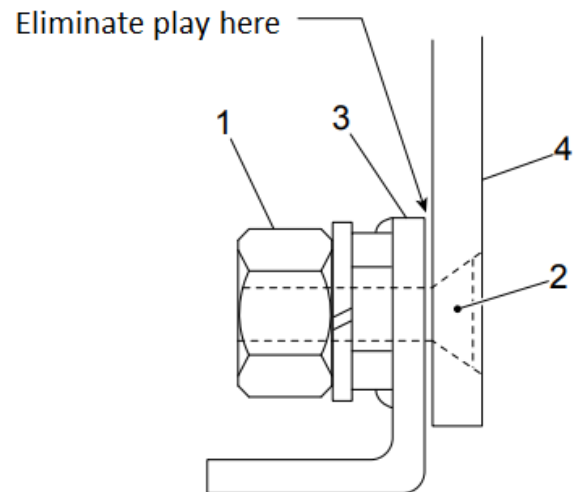
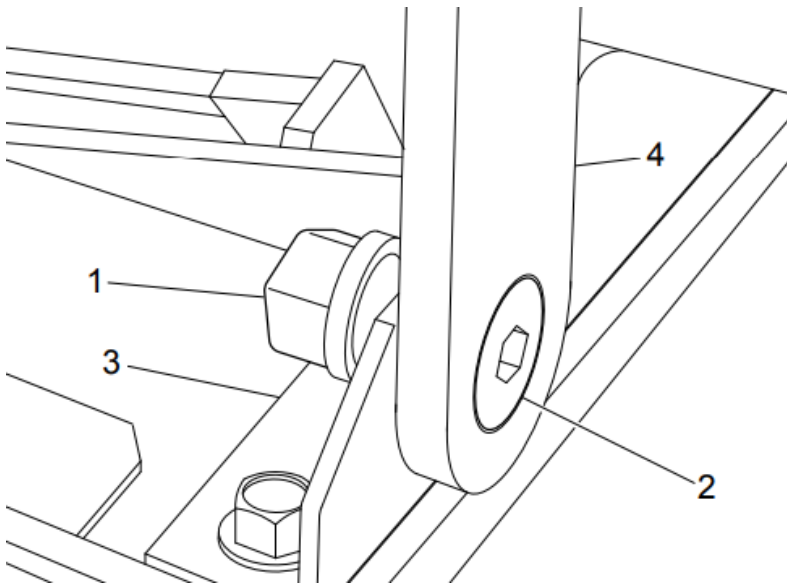

Figure 137 Sharpener frame adjustment

MAINTENANCE & AJUSTEMENTS

F-N-R TRANSMISSION SHIFTER ARM ADJUSTMENT

FIGURE 138

To adjust shifting on the main transmission:

1. Shift the transmission to NEUTRAL before proceeding.
2. Hold the rod (item 1) in place with pliers to unscrew the nut (item 2). Remove the rod, noting the order of the spacers (item 3). Release the cylinder (item 7).
3. Loosen nut (item 4) and tighten the bolt (item 5) as much as possible. Pull on the clutch arm (item 6) while turning the transmission drive pulley to allow easier shifting. Pull the arm as much as possible towards the bolt head (item 5) until you hear a "CLICK" inside the transmission. This means that the reverse gear (REVERSE) is obtained.
4. Unscrew the bolt (item 5) and adjust to obtain a clearance of 1/8" (3 mm) between the gear change support and the adjuster bolt head.
5. Lock the bolt in place with the locking nut (item 4).
6. To adjust the FORWARD gear, repeat steps 3 & 4 but for the FORWARD gear. The adjuster bolt (item 8) is opposite (item 5). Push the clutch arm (item 6) while turning the transmission drive pulley to allow easier shifting. Push the arm as much as possible towards the bolt head (item 8) until you hear a "CLICK" inside the transmission. This means that the reverse gear (FORWARD) is obtained. Obtain a clearance of 1/8" (3 mm).
7. Shift the transmission back to NEUTRAL. Replace the rod (item 1) and the washers (item 3) as they were.

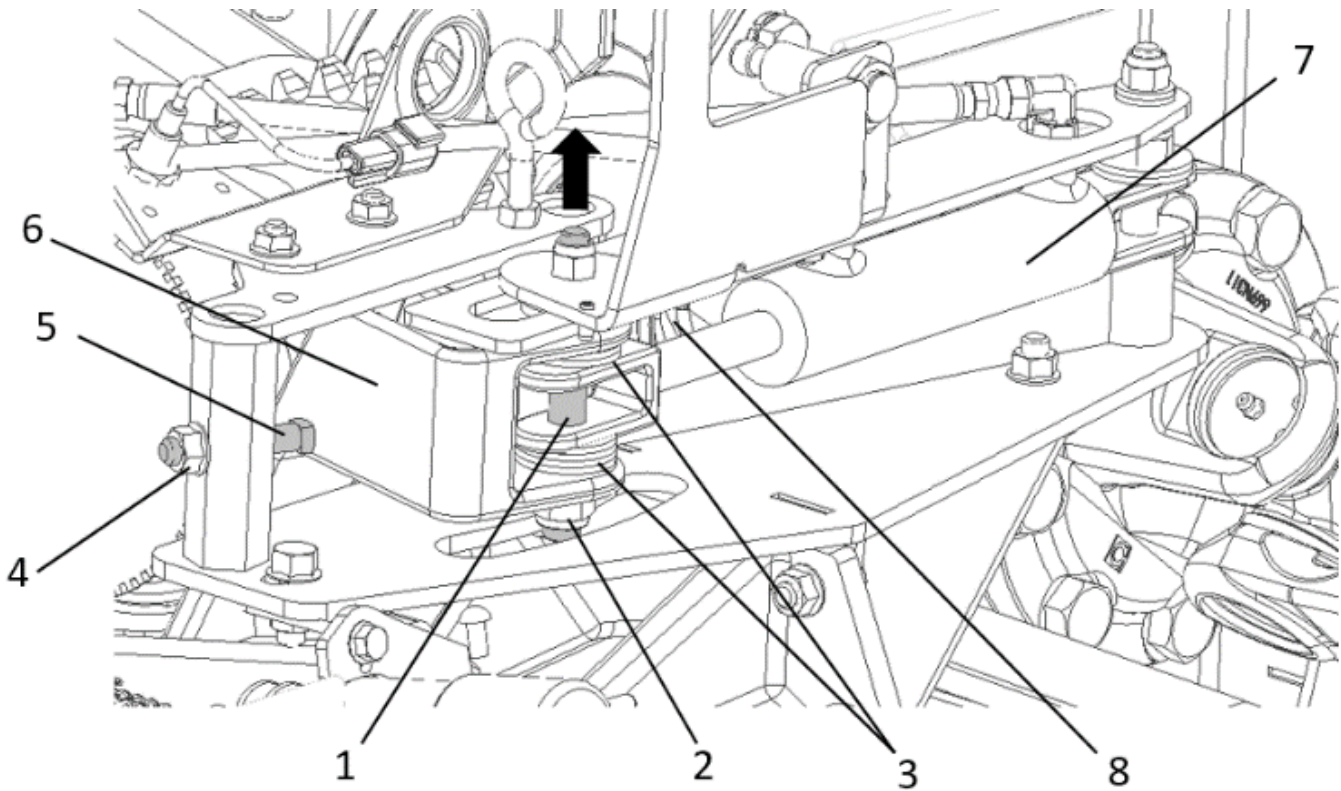

Figure 138 Lever adjustment

MAINTENANCE & AJUSTEMENTS

F-N-R TRANSMISSION SENSOR ADJUSTMENT

The 3 sensors on the transmission (item 1) are used for semi-automatic control of the clutch cylinder (item 5). To adjust these sensors, follow the following procedure:

NOTE: Adjusting the REVERSE, NEUTRAL and FORWARD shifting of the clutch arm should be done before adjusting the sensors. Refer to F-N-R TRANSMISSION SHIFTER ARM ADJUSTMENT.

1. Put the transmission in NEUTRAL. The shift indicator (item 3) should have a slight play from left to right.
2. Adjust the 3 sensors so that they clearance of less than 3mm (1/8") from the shift indicator plate (item 3) without making contact with them.
3. Loosen the nut (item 4) of the sensor support (item 2).
4. Switch the metal detection system (ON) and slide the support (item 2) slowly towards the shift indicator plate (item 3) just until the indicator lamp of the bottom sensor (item 1) comes on.
5. Temporarily tighten the nut (item 4).
6. Shift the transmission to REVERSE and then release the controls so it returns to NEUTRAL. Confirm that check that the clutch arm is fully engaged on the centering ball (audible click) when it returns to the NEUTRAL position.
7. Check the adjustment several times by shifting to the FRONT and REVERSE position and make sure that the clutch arm returns to its NEUTRAL position from both directions.
8. Tighten all the nuts.

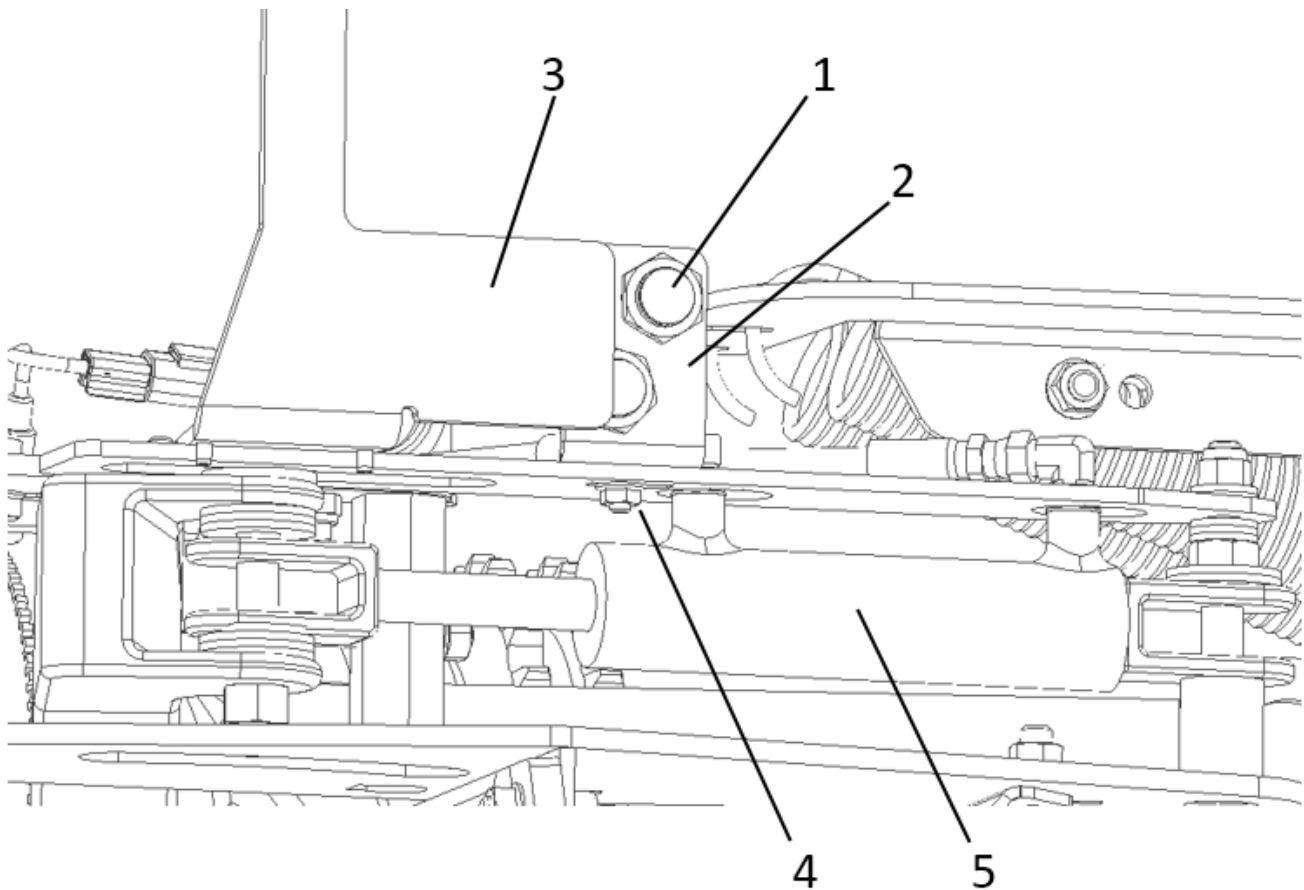

Figure 139 Shifter sensor adjustment

MAINTENANCE & ADJUSTMENTS

FEED ROLL STOPPING MECHANISM ADJUSTMENT

The mechanical system stop of the metal detector allows the feed rolls to stop within 1/20 of a second when ferrous metal is detected. This mechanism includes a stop pawl (item 1) controlled by a solenoid (item 2), a ratchet wheel (item 3), a rubber disc shock absorber (item 4), an overload clutch (item 5) and a transmission actuator that switches from the FORWARD to the NEUTRAL position automatically.

Periodically check these components for proper operation. Make sure that all bolts and nuts are well tightened. Tighten the stop pawl bolt (item 10) and make sure the stop pawl rotates freely.

The spring tension (item 6), the small chain (item 8), the solenoid rubber protector (item 7) and the solenoid cap (item 9) should all be checked for proper operation.

1. Tighten the two bolts on the 1" diameter shaft (item 12) and lightly tighten the bolt (item 13) to allow the free movement of the metal detector stopping system.
2. Tighten the rubber washers by tightening the nut (item 14) until only one or two threads exceed the nut.
3. Adjust the stop pawl chain (item 8) so that the pawl clears the ratchet wheel (item 3) when the solenoid is energized. Once the solenoid is energized, the chain must have some loose when you try to pull back the stop pawl manually.
4. Inside the solenoid, a micro-switch shifts the solenoid from the "pull" to the "hold" coil. The "pull" coil draws 30 amps and is sustained only a few seconds by the system.
5. If the pull coil is on for a longer period, the system will emit a fast "beep". The "hold" coil draws only 0.7 amps.
6. The solenoid (item 2) can be checked with an ohmmeter.

NOTE: The power to the solenoid must be OFF to measure the impedance. Disconnect the wires to the solenoid.

7. The "pull" coil should read 0.7 ohms between the solenoid connections when the system is off.
8. The "hold" coil can be tested by pushing the shaft completely inwards (activating the micro switch) and should read 17 ohms when the system is off.

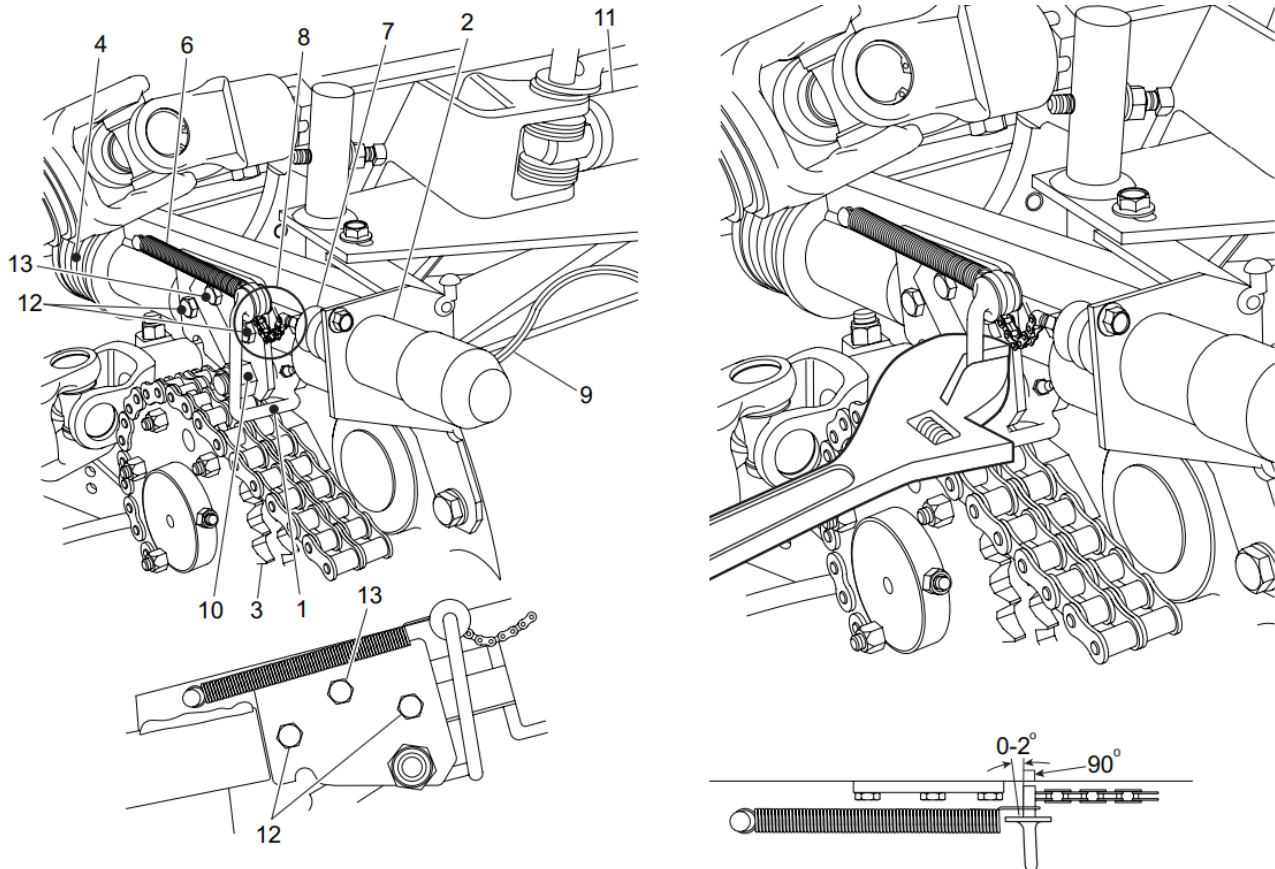

Figure 140 Stop pawl adjustment

MAINTENANCE & AJUSTEMENTS

SPEED SENSOR ADJUSTMENT

Speed sensors are required for the various forage harvester control systems. One sensor is located on the cutting head shaft (item 1) and another is located on the top feed roller drive shaft on the F-N-R transmission (item 2).

The feed roll sensor (item 2) is necessary for the operation of the metal detector. If it is not active, the self-calibrated detection threshold is not active and the system is less sensitive. If the roller speed signal is not available or bad, an alarm consisting of 2 consecutive beeps will sound in the control box. The operation of the forage harvester is still allowed.

The cutting head sensor (item 1) is necessary for the safety bolt failure detection system on the cutting head drive shaft to cut the power in this eventuality and avoid jams. If the controller does not perceive the signal from this sensor or it detects too much noise, a drive failure detection is triggered. The transmission is shifted to neutral and a drive failure alarm is triggered (long beep followed by quick pause) (see Figure 122).

To adjust the sensors:

1. Slightly loosen the sensor bolt (item 3).
2. Center the sensor on the encoding disc (item 4).
3. Adjust the nuts on the sensor achieve a gap of 1mm (0.040") between the sensor face and the disc.
4. Tighten the two nuts to secure the sensor in place and reverify the gap.

NOTE: Ensure there is no contact between the sensor and the disc at any time. Rotate the shaft completely by hand to verify that there is no contact after adjustments are completed.



DANGER: Always stop the PTO and tractor engine before adjusting any speed sensor.

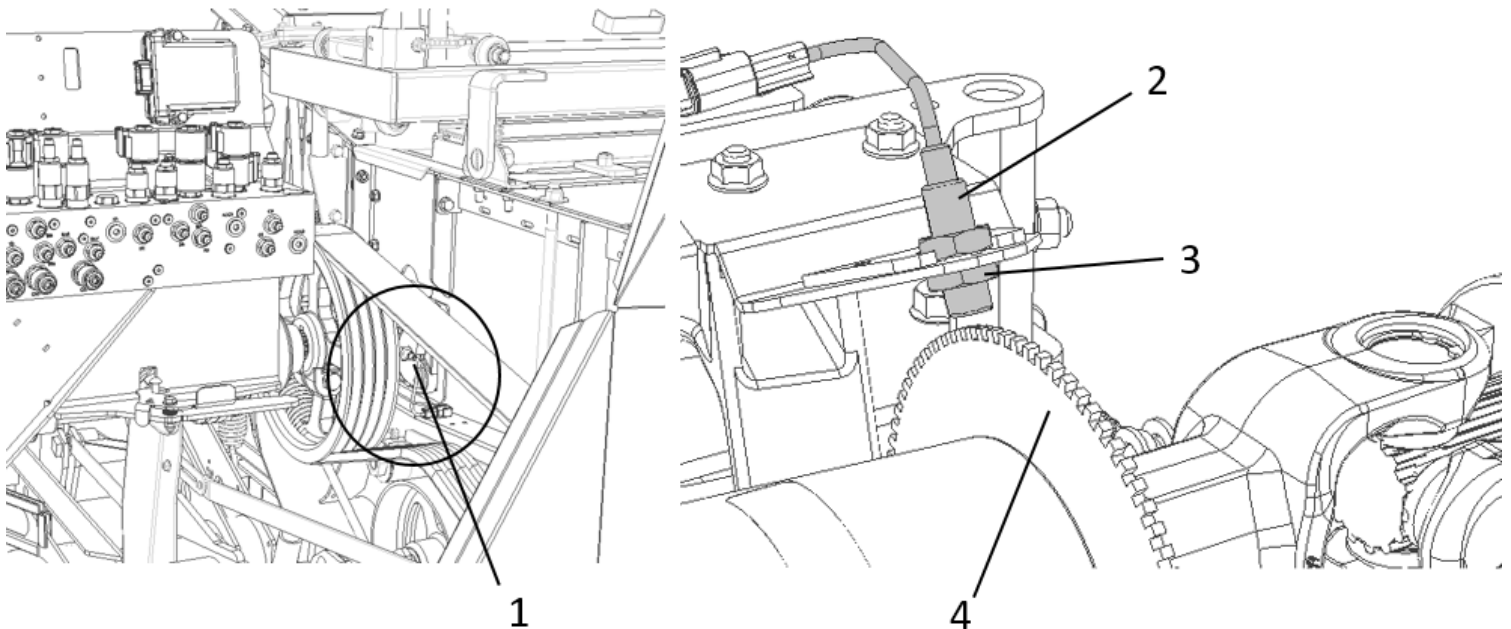

Figure 141 Ajustement des capteurs de vitesse

MAINTENANCE & ADJUSTMENTS

ELECTRONIC CONTROL UNIT & CONNECTOR CLEANLINESS

Electrical and electronic problems can cause intermittent or one-time problems that are difficult to diagnose. To ensure long term durability and proper operation, follow these recommendations:

1. Never wash connectors or controllers. Clean with an air jet or cloth only.
2. Avoid accumulation of debris, oil and dust on electrical components.
3. Apply contact cleaner to exposed connectors (such as the main connector) regularly and once a year for other connectors.

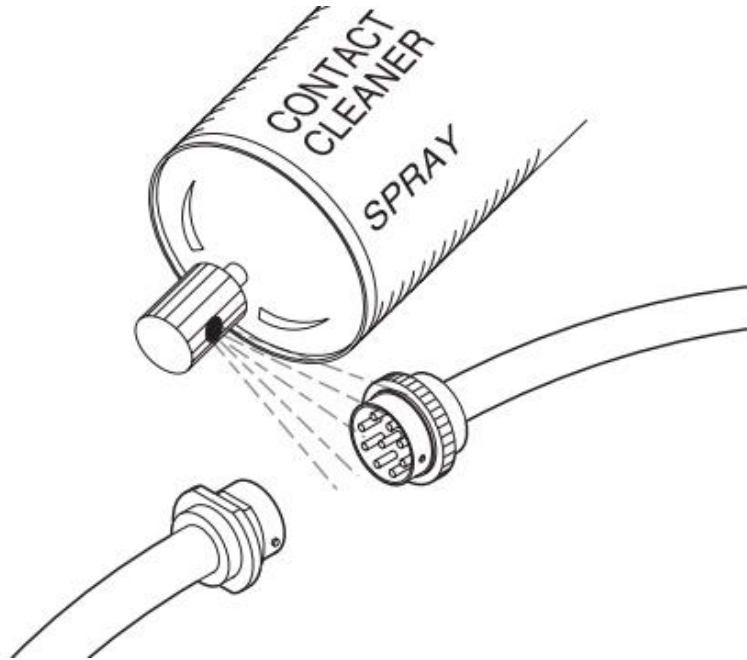

Figure 142 Connector maintenance

WELDING ON THE HARVESTER

Before welding on the forage harvester, for whatever reason, make sure not to compromise the structure of the machine, affect its performance or affect its safety systems. Welding on the machine may void the warranty.

To avoid damaging the electrical and electronic circuits of the forage harvester, always completely isolate the forage harvester from the tractor, and make sure that no electrical supply is connected.



CAUTION: Welding can cause significant damage to electronic systems.

MAINTENANCE & AJUSTEMENTS

STORAGE PROCEDURE

NOTE: Never pressure wash the electronic controls, bearings, solenoid valves, hydraulic valve manifolds or other component containing seals (Figure 143).

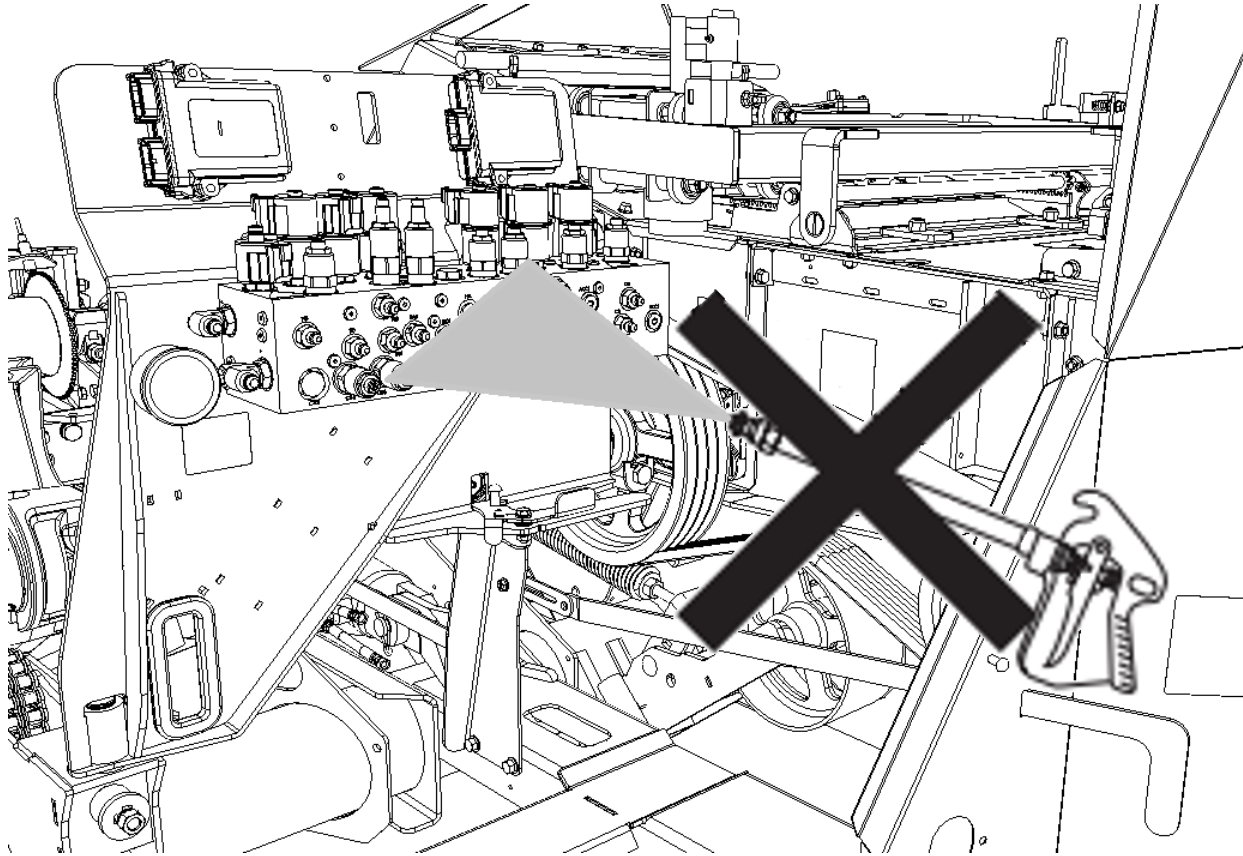

Figure 143 Pressure washing

STEP 1

To prevent any accumulation of dirt, soil, material, excess of grease, or any other substance which could absorb water and cause moisture and rust, clean the forage harvester thoroughly.

STEP 2

When equipped with processor rolls, run the harvester for a few minutes and check the processor rolls bearings for any overheating. With any temperature excess or abnormal noise, replace the faulty bearing(s).

NOTE: A regular inspection of the processor high speed bearings is essential to ensure long-term durability.

STEP 3

Lubricate the entire machine and check oil levels.

STEP 4

Clean and lubricate all chains.

STEP 5

To prevent rust when paint is damaged, apply a new coat of paint on exposed surfaces.

STEP 6

Order the necessary spare parts and repair the forage harvester before beginning the new season.

NOTE: After cleaning and full lubrication, run the harvester for a few minutes to allow the lubricant to penetrate and spread uniformly. Store the harvester in a clean and dry place.

STEP 7

Remove tension from all of the belts.

MAINTENANCE & AJUSTEMENTS

STEP 8

Check condition of guards and safety decals. Replace them if necessary.

STEP 9 - FIGURE 144

At the end of the season, drain the liquid incorporation system using antifreeze.

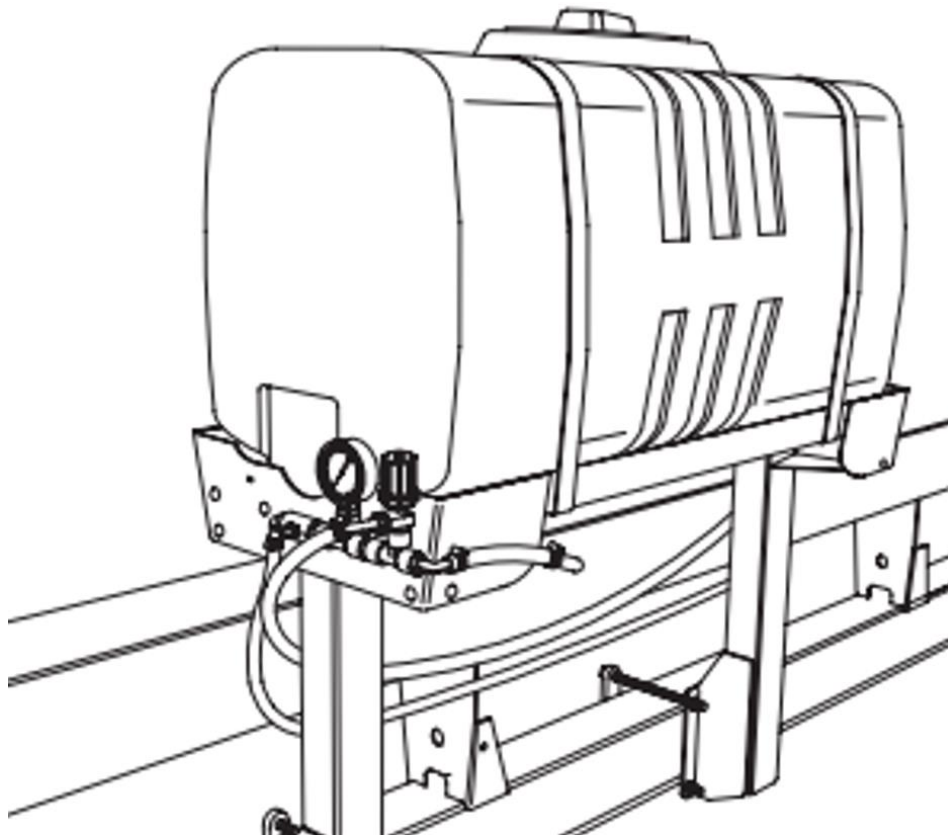

Figure 144 Liquid incorporation system

NOTE: After cleaning and complete lubrication, run the forage harvester for a few minutes to spread the grease evenly within the bearings and on the roller chains. The forage harvester should be stored in a dry, clean area.

DIAGNOSTICS & TROUBLESHOOTING

CONTROLLER ALARMS AND LOGIC

This flowchart represents possible states of the harvester controller, beginning with powering on of the control box and metal detector. The details are explained in the table below titled CONTROL BOX, TRANSMISSION AND METAL DETECTOR.

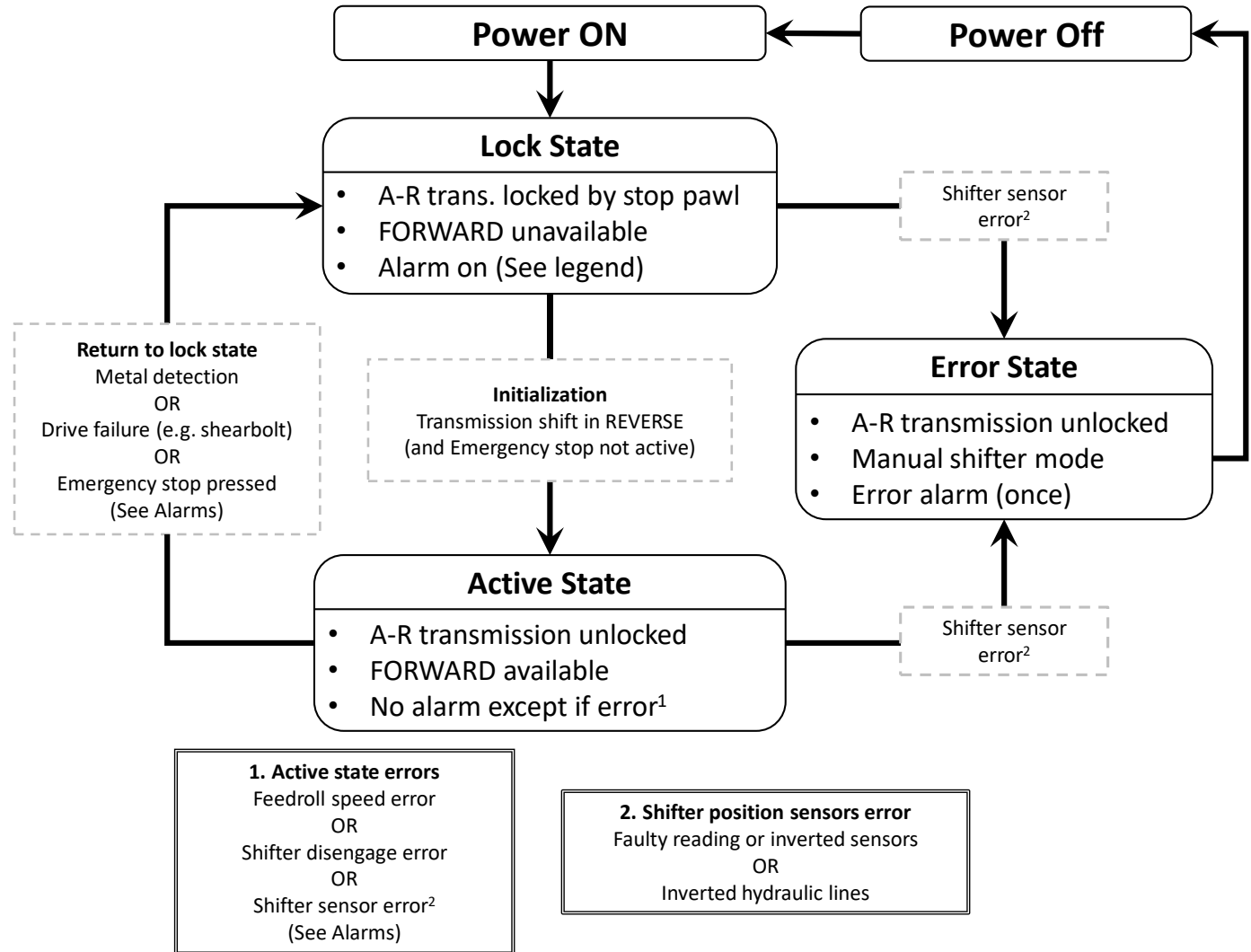
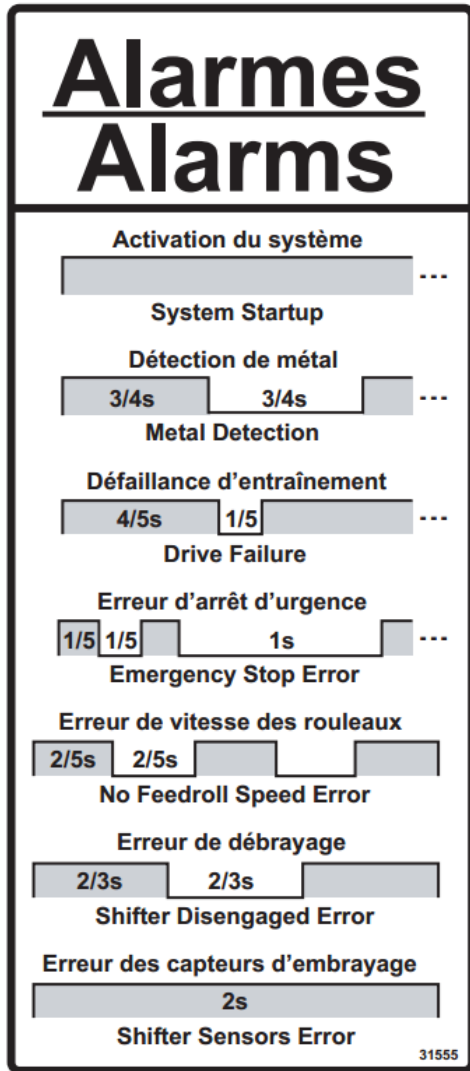

Figure 145 Harvester controller logic

TRANSMISSION SHIFTER LOGIC

This flowchart shows the F-R transmission shifter logic (with *FerroDtec* system), starting with powering up the control box. It displays the link between the commands of the operator, the shifter reaction and shifter position sensors.

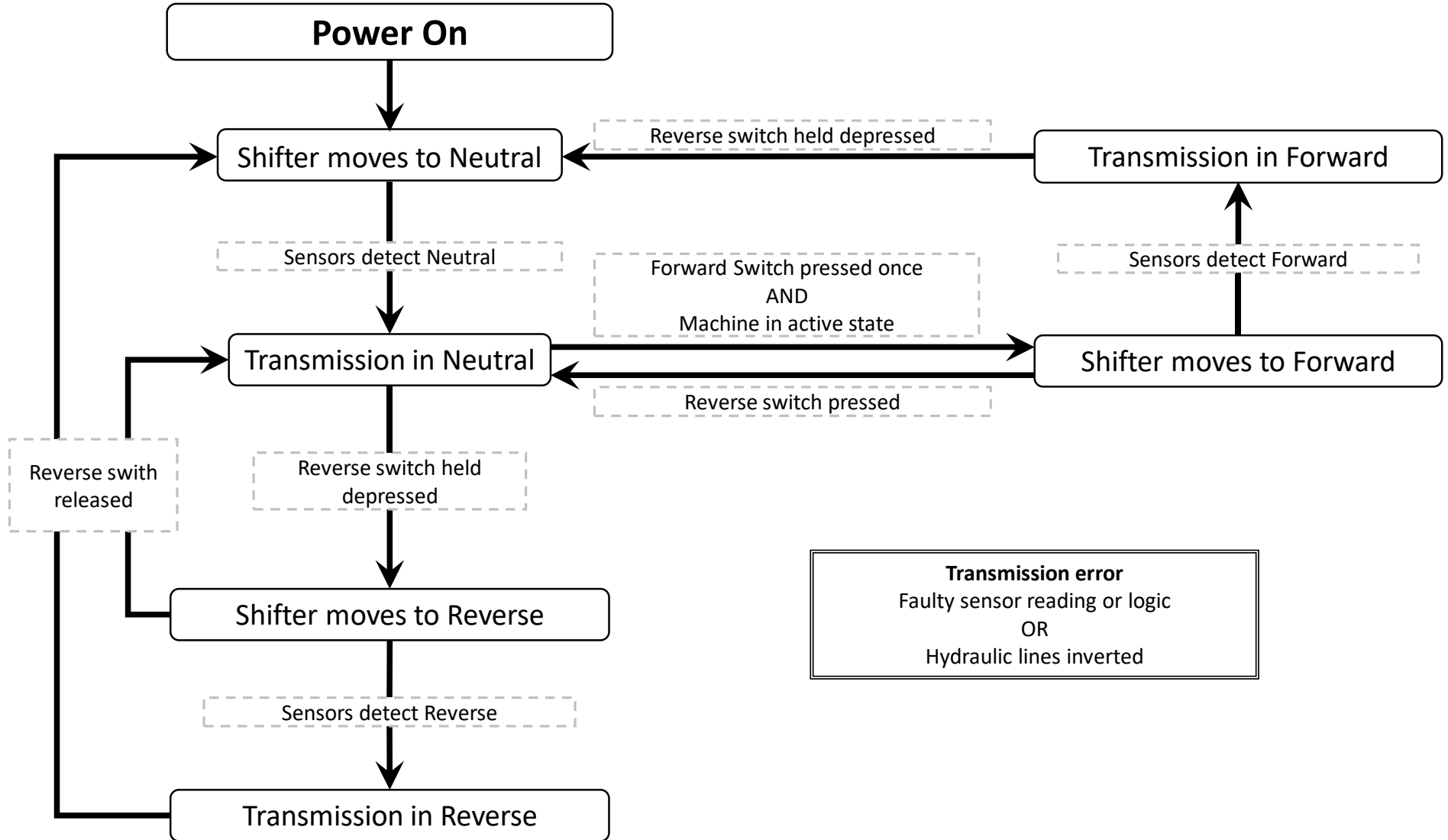

Figure 146 Shifter logic

DIAGNOSTICS & TROUBLESHOOTING

CONTROL BOX, TRANSMISSION AND METAL DETECTOR

PROBLEM/ALARM	PROBABLE CAUSES	EXPLANATION/SOLUTION
System Start-up. (Alarm)	Lock State. System not initialized.	The machine starts in lock mode and prevents forward rotation of the transmission. The transmission shifter moves automatically to neutral. The operator must shift to reverse to initialize the system and turn off the alarm. Once initialized, the system will be in an active state and ready to be shifted into forward and the detector will be enabled.
Metal detection. (Alarm)	A ferrous material has been detected.	Follow recommended stopping procedure. Remove the ferrous material and reinitialize the detector. Detected objects can be difficult to find within the crop material.
Metal detection, but no ferrous material found - false detection. (Alarm)	Severe impact on the feed rolls.	During certain conditions, dry corn for example, can cause heavy vibrations to the metal detector roll. Rocks or hard debris can also cause false detections. Lower the detector sensitivity temporarily to eliminate these false detections. (see METAL DETECTOR SENSITIVITY ADJUSTMENT)
	A metal part touches the detector roll, or is vibrating in its vicinity.	Vibrations and impacts can cause some parts or fasteners to become loose. Rubbing metal parts on the roll will cause steel particles to stick to the roller. Check surrounding parts for loose hardware or debris.
	A detector roll bearing is damaged or loose.	With the machine stopped, insert a piece of wood between the front feed rolls and check for any play in the feed roll shaft. Replace the bearing if necessary.
	Top feed roll plastic stop worn out or absent.	Check the condition of the red plastic feed roll stop. If worn out, there will be a direct metal-metal contact that may cause severe vibrations.
	Damaged or pinched antenna/sensor cable.	Inspect the cable over the entire length and from all angles. Measure the resistance between each of the 3 antenna wires. The impedance between the Black & Red wires should result in a value between 880-950 Ω and infinite between either colour and the ground wire. Repair and/or isolate the cable as necessary.

DIAGNOSTICS & TROUBLESHOOTING

	<p>The sensor/antenna is damaged.</p>	<p>Impedance between the colored wire is less than 800Ω or higher than 1kΩ would indicate that antenna coil wire is damaged or short, there is a short circuit between the signal wires and the ground, the epoxy mould housing the magnet-coil assembly is broken or detached from the casing OR the fasteners holding the sensor on the shafts are damaged or loose.</p> <p>With the PTO stopped and disconnected, turn on the control box and detector, then set the harvester in forward. Check if vibrations or impacts on the feed roll causes metal detections. Replace the antenna if necessary.</p>
<p>No metal detection or abnormal behavior. (No alarm)</p>	<p>Damaged breakers, wires, bad connections or failed controller.</p>	<p>Check the wiring and all connectors. Make sure the control box power offers a steady 12V. Consult a technician for a controller field diagnostic with computer software tools.</p>
	<p>The antenna cable is damaged or cut.</p>	<p>Inspect the cable over the entire length and from all angles. Measure the resistance between each of the 3 antenna wires. The impedance between the Black & Red wires should result in a value between 880-950 Ω and infinite between either colour and the ground wire. Repair and/or isolate the cable as necessary.</p>
	<p>Antenna internal damage.</p>	<p>If impedance between the Red & Black wires is less than 800Ω or higher than 1kΩ, the antenna coil wire may be damaged or short OR there is a short circuit between the signal wires and the ground.</p> <p>Replace the antenna inside the detector roll.</p>
	<p>Amplifier or controller damaged.</p>	<p>Ensure the controller and amplifier black casings are not damaged or cracked. Refer to the service manual.</p>
<p>Drive failure. (Shear bolt or clutch slippage) (Alarm)</p>	<p>Shear bolt on cutter head shaft has failed or friction clutch slipped.</p>	<p>Turn off the tractor, inspect the shear bolt and collect the broken halves if this is the issue. Replace the damaged bolt with provided bolts in toolbox.</p> <p>Refer to the FRICTION CLUTCH (OPTIONAL) section of this manual (if equipped).</p>
	<p>The cutter head speed sensor is damaged or out of adjustment.</p>	<p>If the shear bolt or clutch is intact, the speed sensor clearance might be too large, or the sensor itself is defective.</p> <p>Ensure the sensor tip is centered with the encoding wheel and adjust the clearance between the two to less than 1 mm or 1/32" OR replace the sensor.</p>

DIAGNOSTICS & TROUBLESHOOTING

Emergency stop error. (Alarm)	The emergency stop stays active.	Make sure the emergency stop button on the control box is not damaged, stuck in the depressed position or that the cable is not cut or disconnected. Replace or repair depending on the case.
Feed roll speed error. (Alarm)	Feed rolls are clogged with crop material.	If an overload has occurred and the feed rolls become clogged, the overload protection clutch on the transmission input pulley will slip and emit a growling sound. Reduce the PTO rpm, then reverse the feed rolls to clear the harvester throat before returning to forward at low speed. Then, rapidly increase the rpm. Repeat, if necessary.
	The detector stop pawl is stuck in the ratchet wheel.	If the stop pawl is jammed in the ratchet wheel, the solenoid will cycle between pause and pulling cycles due to a current overload protection in the circuit. With the PTO at idle, reverse the feed rolls to free the stop pawl. Forward motion should now be possible.
	Solenoid stroke is limited.	If the solenoid can't pull to its full stroke, it will cycle between pulling and pause phases for a few seconds. Make sure the stop pawl pivot is greased and is free to move. When the solenoid is activated, make sure there is still some play in the pawl (the solenoid must pull only against the weight of the pawl and the spring force).
	The solenoid is not receiving a steady +12V, is stuck or damaged.	Make sure the control box power offers a steady +12V. Check all connections and clean them with electrical contact cleaner, if necessary. With the PTO turned off and disconnected from the tractor, initialize the detector. Disconnect the wires from the coil under the rubber boot and verify the voltage is a steady +12V. With the control box and tractor turned off, ensure the piston is free to move its full stroke. With the wires disconnected, check the impedance across the solenoid terminals with the shaft in the extended and compressed positions. Values should be 0.7Ω with the shaft stroke extended and 17Ω with the shaft stroke compressed). Clean, repair or replace the solenoid according to the issue.
	The feed roll speed sensor is damaged, disconnected or out of adjustment.	If all the mechanical components driving the feed rolls are operating normally and the feed roll speed error sounds while the feed rolls are turning, the speed sensor may be the issue. Verify the sensor is centered with the encoding wheel and the clearance is under 1 mm or 1/32" between the sensor tip and the encoding wheel. Or, replace the sensor.
Feed roll speed error. (Alarm) (Cont.)	The transmission is damaged.	Different failures in the F-R transmission concerning gears, shifter, jaws, sprocket chains, etc. may prevent the feed rolls from turning. Refer to the service manual or dealer for transmission repair.

DIAGNOSTICS & TROUBLESHOOTING

Shifter disengaged error. (Alarm)	Return pressure spike or air in the shifter cylinder caused it to disengage from FORWARD.	The control will correct this behavior automatically by shifting back to full stroke in forward. If the error persists, turn OFF the PTO and cycle the shifter cylinder several times between FORWARD and REVERSE to bleed off any air in the hydraulic lines. Otherwise, contact your dealer for a valve or cylinder inspection.
	Oil leak to the shifter cylinder.	Check for oil leaks in the cylinder hydraulic lines. To avoid injuries due to hot fluids, use cardboard or wood to check for leaks when shifting. OR, contact your dealer for inspection by a qualified technician.
Shifter sensor error. (Alarm)	One or both proximity shifter sensors are damaged.	With the PTO turned OFF and the control box ON, test the sensors by placing a ferrous material within the proximity of the sensor face. Verify that the indicator light on the sensor turns on.
	Loss of adjustment of the shifter sensors or misaligned	Make sure that both sensors are turned on in Forward position, and one when shifting to neutral from both reverse and forward position.

EJECTION

PROBLEM	PROBABLE CAUSES	SOLUTIONS
Knocking sound coming from the accelerator.	The accelerator is gummed.	Use a liquid incorporation system to lubricate the crop channel.
	Accelerator misadjusted.	Adjust according to specifications – See service manual.
Insufficient throwing capacity or distance.	PTO speed is too low.	Maintain recommended PTO speed with throttle or reduce forward speed.
	The accelerator or drum contour is gummed.	Clean the crop channel by harvesting wet crop over a short distance or washing. Use a liquid incorporation system to lubricate the channel.
	Accelerator blades are not adjusted correctly.	Adjust the accelerator clearance – See service manual.
	Belts slip.	Check belts for wear and tear, grease contamination and pulley alignment. Check belt tension.
	Wear plate on spout is worn or punctured.	Replace the wear plate.
	Worn accelerator blades.	Replace all four blades if any tip is rounded off.

DIAGNOSTICS & TROUBLESHOOTING

FEEDING

PROBLEM	PROBABLE CAUSES	SOLUTIONS
Transmission clutch slips.	Very dry or short hay or straw.	Loosen the feed roll spring tension. Check the smooth roll cleaner adjustment.
	Excessive lubrication.	Disassemble the clutch to remove excess grease.
	Damaged internal springs.	Disassemble the clutch to replace broken springs or worn cams. Replace clutch.
	Front grain pan is installed when windrow harvesting.	Remove the front pan. (item 4, Figure 32 on page 35)
	Feed roll stops worn out.	Replace or flip over the red feed roll stops.
	PTO is stopped before the crop has gone through the channel.	Disengage the PTO and lower the tractor engine rpm only after all the crop has passed through the crop channel and has been ejected.
	Knives worn or not correctly adjusted.	Sharpen the knives and adjust the shear bar.
	Smooth roll scraper out of adjustment.	Clean and adjust the smooth roll scraper.
Silage is thrown back over the front feed rolls.	Insufficient PTO speed or processor roll blockage.	Clean the channel around the processor rolls and maintain PTO rpm speed.
	PTO stop when crop remained in channel.	Clean the processor roll channel section. Maintain PTO rpm when harvesting.

LIQUID INCORPORATION SYSTEM

PROBLEMS	PROBABLE CAUSES	SOLUTIONS
Lack of flow.	Dirty filter, Bad electrical connection, Burnt fuse.	Clean the filter and pump, check all electrical connections and check the fuse. If necessary, replace the pump.

DIAGNOSTICS & TROUBLESHOOTING

CUTTING

PROBLEMS	PROBABLE CAUSES	SOLUTIONS
Silage fraying or uneven edge lengths.	Shear bar is not parallel to the knives or is too far away.	Adjust and correct the shear bar alignment.
	Insufficient crop flow.	Increase forward speed or windrow size.
	Knife cutting edge(s) worn out.	Sharpen the knives.
	Worn out shear bar.	Remove and flip over shear bar or replace it. Ensure the tungsten edge always faces upwards.
	Crop stems not aligned with windrow.	Adjust crop merger or harvest untouched windrows when possible to maintain crop stems aligned with harvester forward direction.
Knives wear out fast.	Shear bar clearance too large or tungsten edge is worn.	Adjust or replace shear bar.
	Too much soil, sand and/or stones picked up in the windrow.	Adjust the pickup height.
	Debris /stones brought in by merger or rake.	Adjust working height of merger or rake.

PROCESSOR ROLLS

PROBLEMS	PROBABLE CAUSES	SOLUTIONS
Loss of corn silage under the processor rolls.	Side deflectors in front of top rolls are worn.	Replace the deflectors.
	Incorrect adjustment of the rear channel pan.	Adjust clearance to 0.5mm (1/64").
	Hay crop residue stuck on edge of rear channel pan.	When reconfiguring from hay to corn silage, always clean the channel plates and pans around the processor rolls to remove any residue.

DIAGNOSTICS & TROUBLESHOOTING

DRIVE

PROBLEMS	PROBABLE CAUSES	SOLUTIONS
Excessive power requirement.	Excessive spacing between knives and shear bar.	Adjust shear bar.
	Length of cut unnecessarily too short.	Increase/modify the length of cut.
	The crop channel is gummed.	Use liquid incorporation system to avoid gumming.
	Smooth roll cleaner is not adjusted.	Clean and readjust smooth roll cleaner.
	Accelerator not correctly adjusted.	Adjust the accelerator clearance.
	Insufficiently ground knives.	Sharpen knives.
	Worn out shear bar.	Remove and flip over shear bar or replace it. Ensure the tungsten edge always faces upwards.
Noisy universal joint.	Implement and tractor PTO shafts are not aligned.	Adjust the height of the front bracket.
	The universal joint yokes at both ends of the harvester PTO shaft are not aligned.	Align joints at both heads to be parallel. The mating spline ends contain a special groove that forces the correct alignment, make sure it has not been tampered with.
	Cross bearings are worn.	Verify shaft alignment and replace cross bearings.
	The draw bar is too short.	Lengthen the draw bar in order to respect the correct dimension (see DRAW BAR EXTENSION).
Cutter head friction clutch slips (optional equipment) – The clutch and surrounding parts are hot.	Worn friction disks.	Replace the disks, maintain the knives sharpened and shear bar adjusted, limit forward speed if the tractor exceeds the harvester power rating. Check the torque limit (Set to max rating from the factory).

DIAGNOSTICS & TROUBLESHOOTING

ELECTRO-HYDRAULIC FUNCTIONS

PROBLEMS	PROBABLE CAUSES	SOLUTIONS
No functions are operational.	Electric power cut off.	Make sure the switch on the control box is ON and power is available. Check that power is available to the controller and valves.
	Hydraulic supply is cut off.	Make sure the tractor SCV is in continuous mode with a flow of approx. 8-11l/min (2-3gpm). Make sure flow is directed to the "P" line. Make sure there are no leaks at the valve manifold.
	By-pass valve is defective. (SV7)	The by-pass valve on the valve manifold is defective (SV7) or its solenoid is burnt or has receives no power when any of the function is activated. Check connections and valve coil, or replace valve.
One function is not available. (e.g. the spout deflector can be lifted, but not lowered)	Valve disconnected. or burnt coil.	Check the voltage at the coils when activated.
	A hose is leaking.	Inspect the hoses, cylinders or motor for leaks.
The spout bounces violently. (‘Stinger’ extension)	Failed accumulator.	Lower the spout and stop to check that the cylinder shows at least 25mm of travel. Replace accumulator. See SPOUT CYLINDER TRAVEL SENSOR ADJUSTMENT.
	Flow control orifice is blocked.	Lower the spout completely, turn off the tractor, remove the accumulator and inspect the orifice disk in the port for any blockage. IMPORTANT: Always lower the spout completely (disconnect the limit switch) before removing the accumulator.

HYDRAULIC CIRCUIT

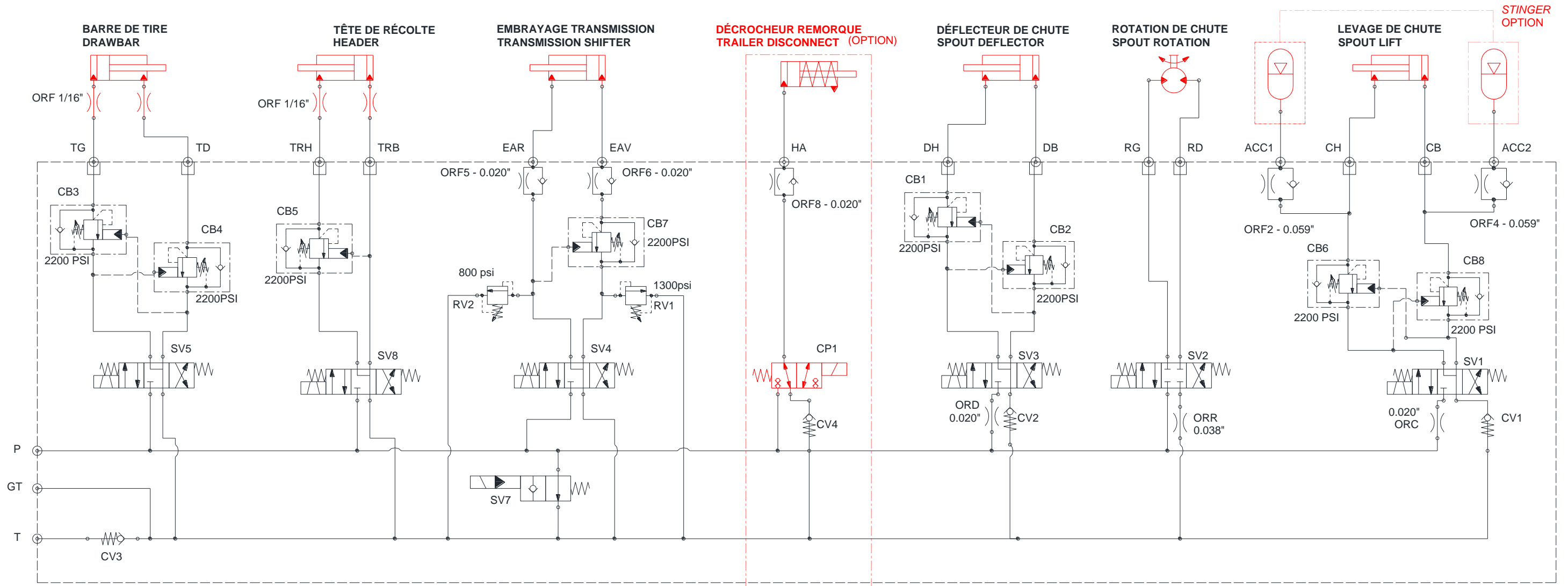

LÉGENDE DES PORTS (FRANÇAIS):

- P : PRESSION
- T : RÉSERVOIR
- GT: JAUGE PRESSION RÉSERVOIR
- TD: BARRE DE TIRE (DROITE)
- TG: BARRE DE TIRE (GAUCHE)
- TRH: TETE DE RECOLTE (HAUT)
- TRB: TETE DE RECOLTE (BAS)
- EAR: EMBRAYAGE (ARRIÈRE)
- EAV: EMBRAYAGE (AVANT)
- HA: DÉCROCHEUR
- DH: DÉFLECTEUR DE CHUTE (HAUT)
- DB: DÉFLECTEUR DE CHUTE (BAS)
- RD: ROTATION DE CHUTE (DROITE)
- RG: ROTATION DE CHUTE (GAUCHE)
- CH: LEVAGE DE CHUTE (HAUT)
- CB: LEVAGE DE CHUTE (BAS)

PORTS LEGEND (ENGLISH):

- P : PRESSURE
- T : TANK
- GT: TANK LINE PRESSURE GAUGE
- TD: DRAWBAR (RIGHT)
- TG: DRAWBAR (LEFT)
- TRH: HEADER (UP)
- TRB: HEADER (DOWN)
- EAR: SHIFTER (REVERSE)
- EAV: SHIFTER (FORWARD)
- HA: TRAILER DISCONNECT
- DH: SPOUT DEFLECTOR (UP)
- DB: SPOUT DEFLECTOR (DOWN)
- RD: SPOUT ROTATION (RIGHT)
- RG: SPOUT ROTATION (LEFT)
- CH: SPOUT LIFT (UP)
- CB: SPOUT LIFT (DOWN)

ELECTRICAL CIRCUITS

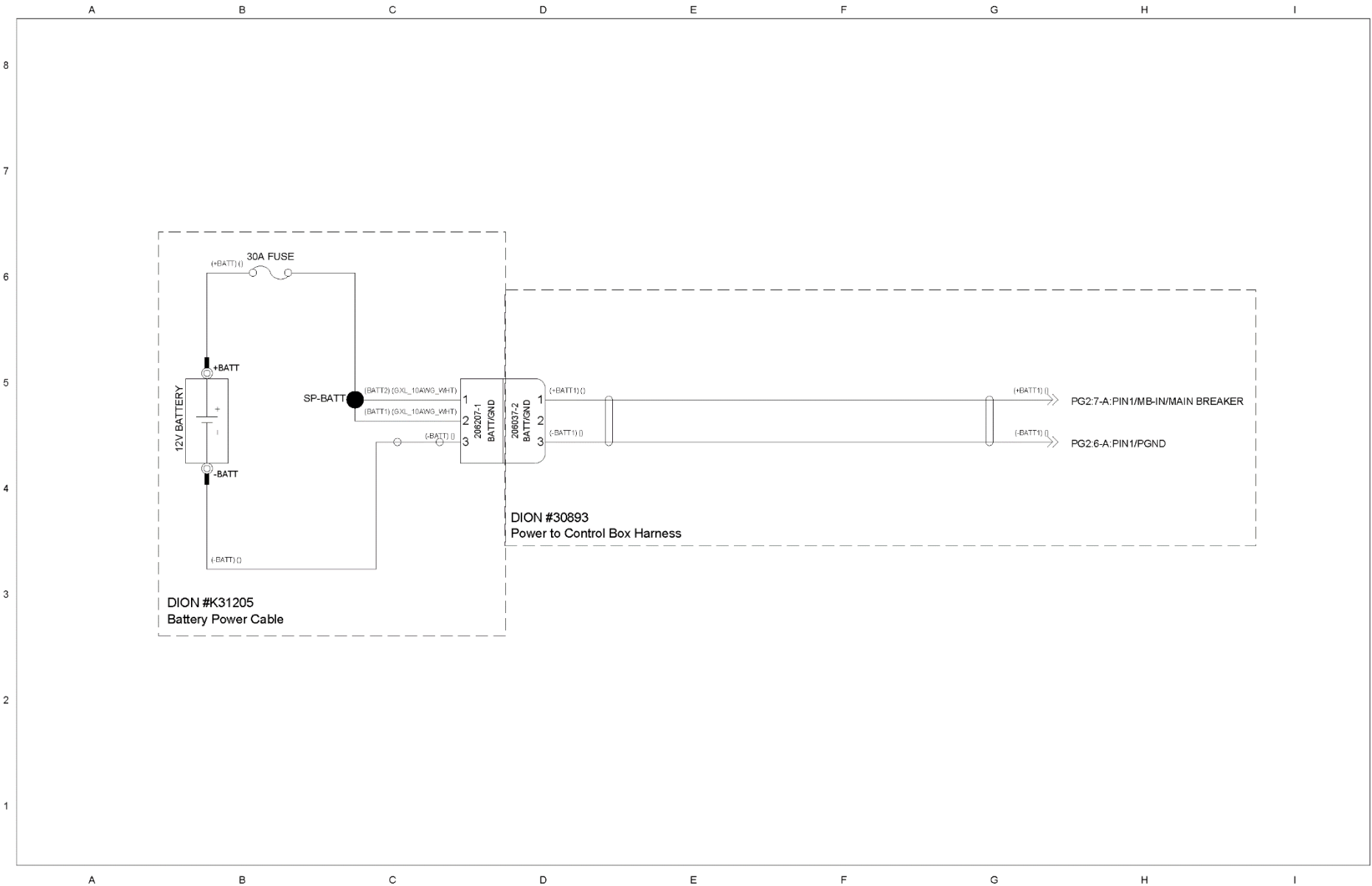

ELECTRICAL CIRCUITS

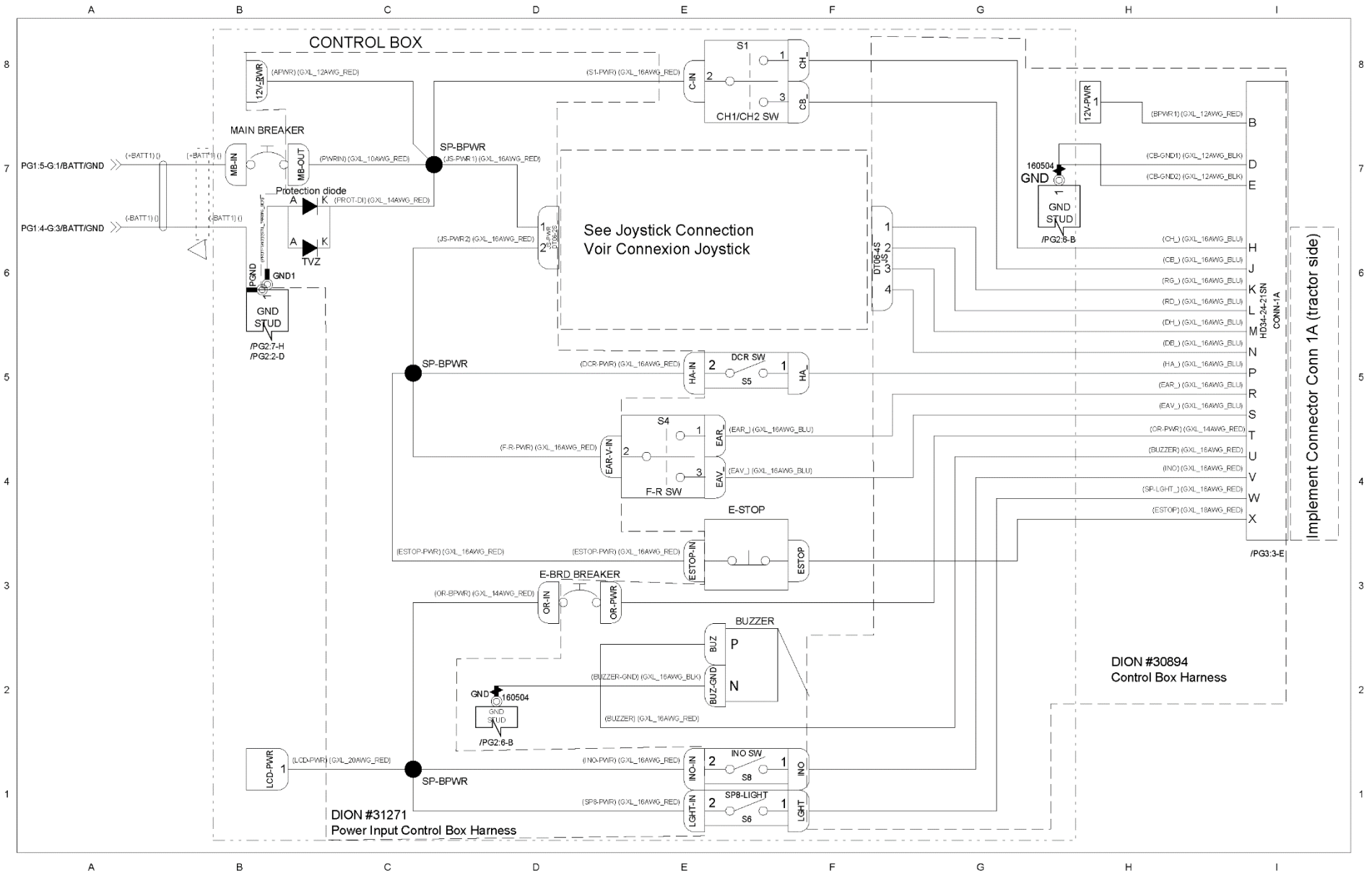

ELECTRICAL CIRCUITS

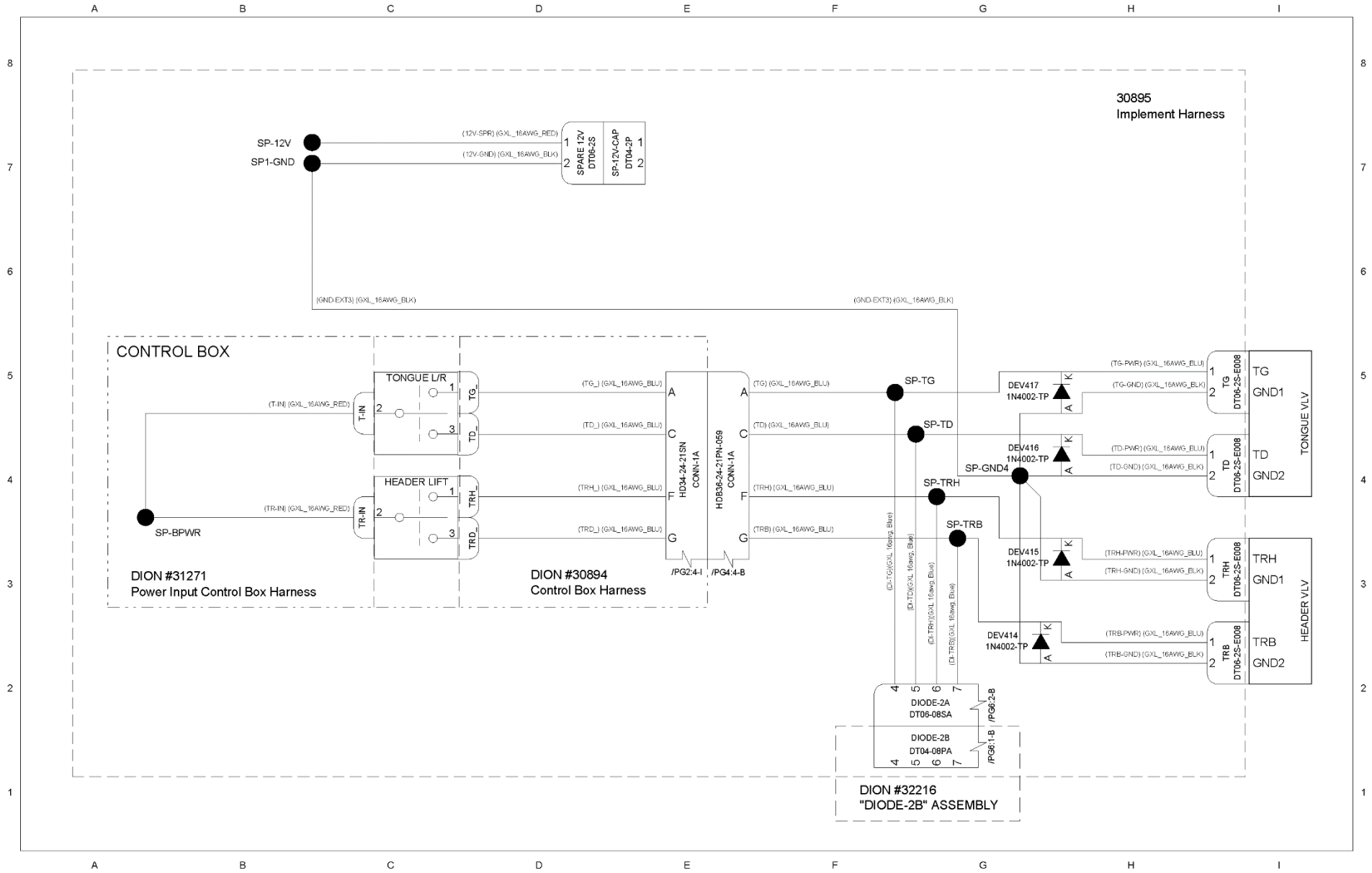

ELECTRICAL CIRCUITS

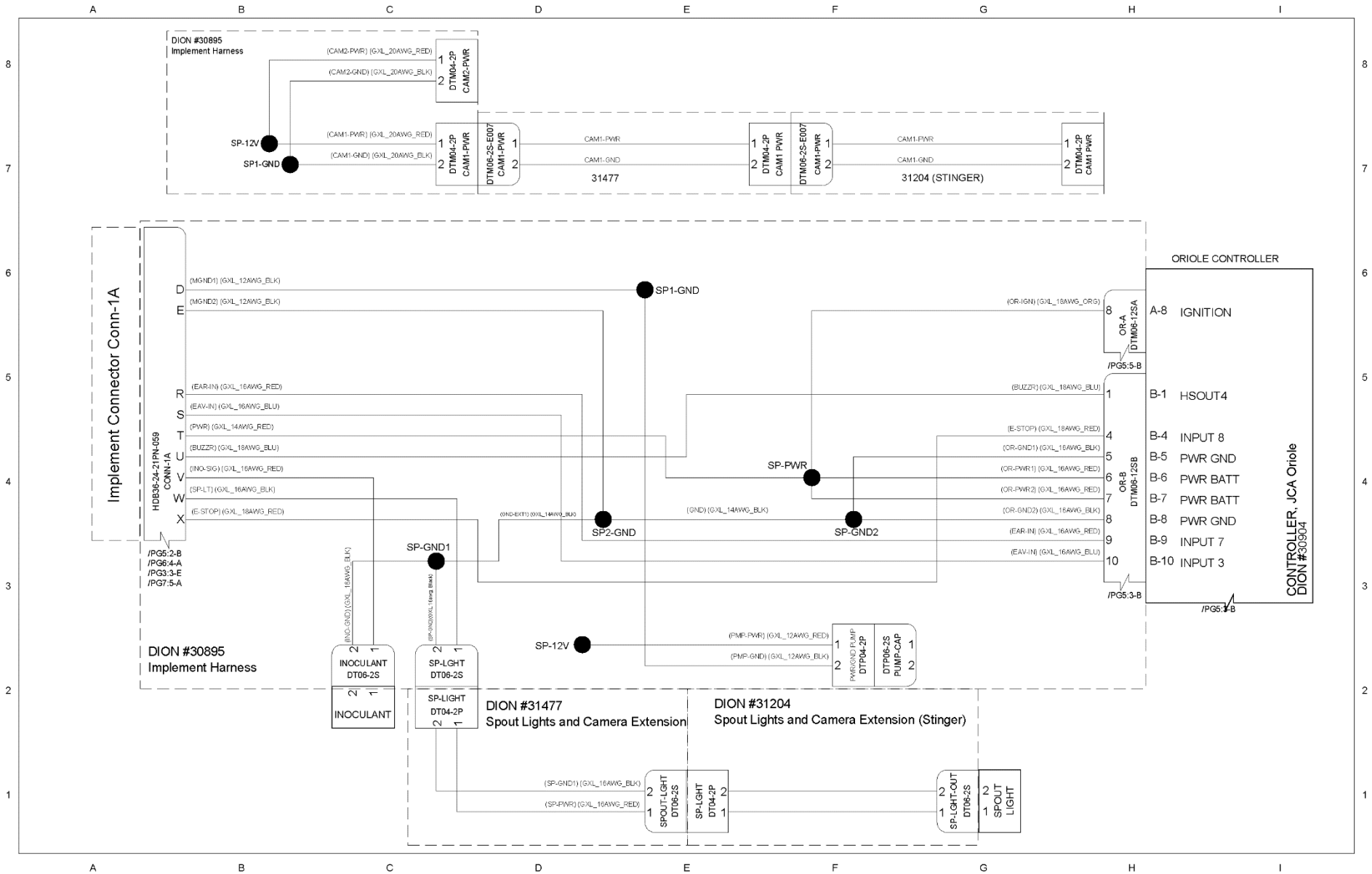

ELECTRICAL CIRCUITS

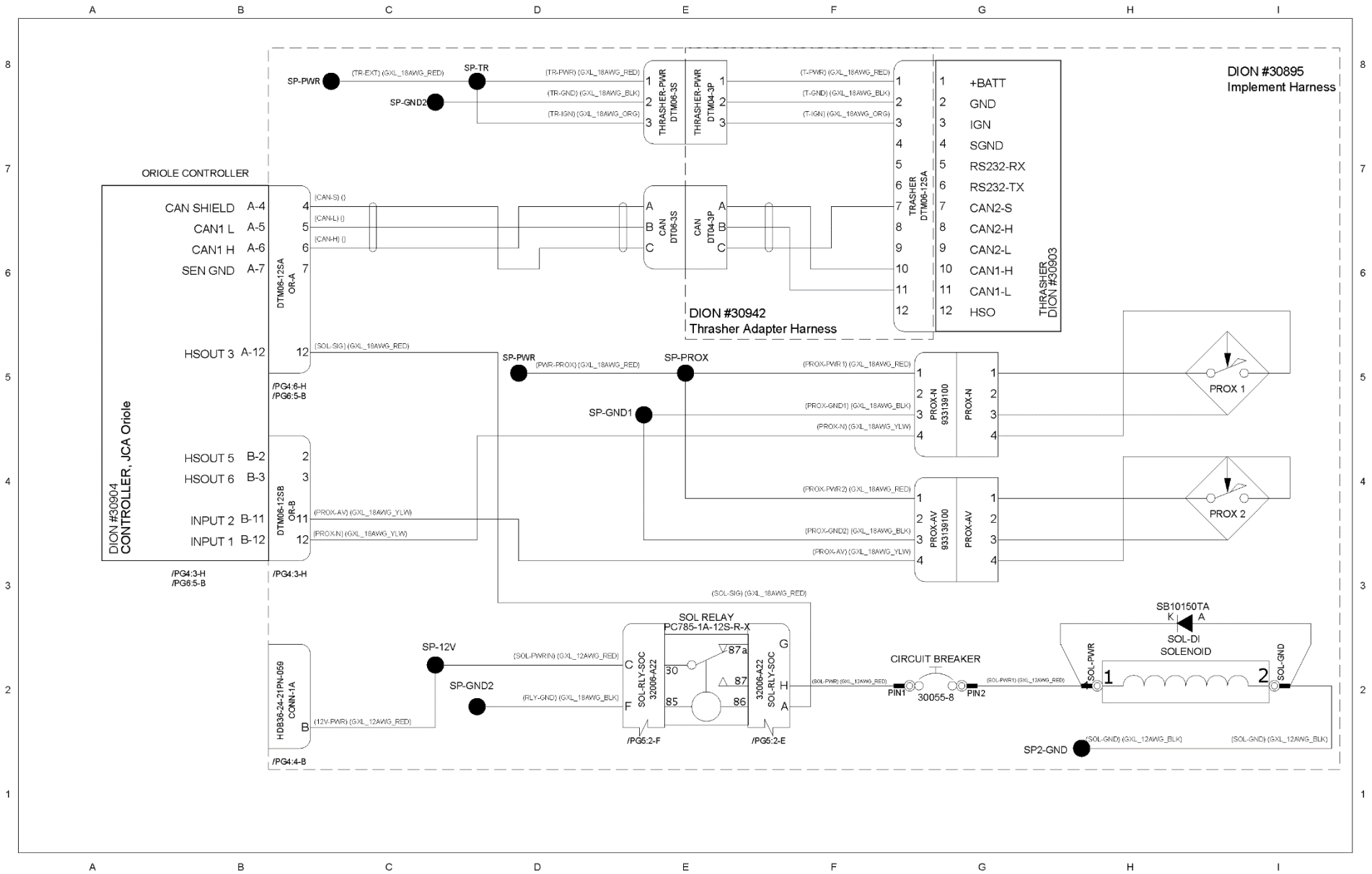

ELECTRICAL CIRCUITS

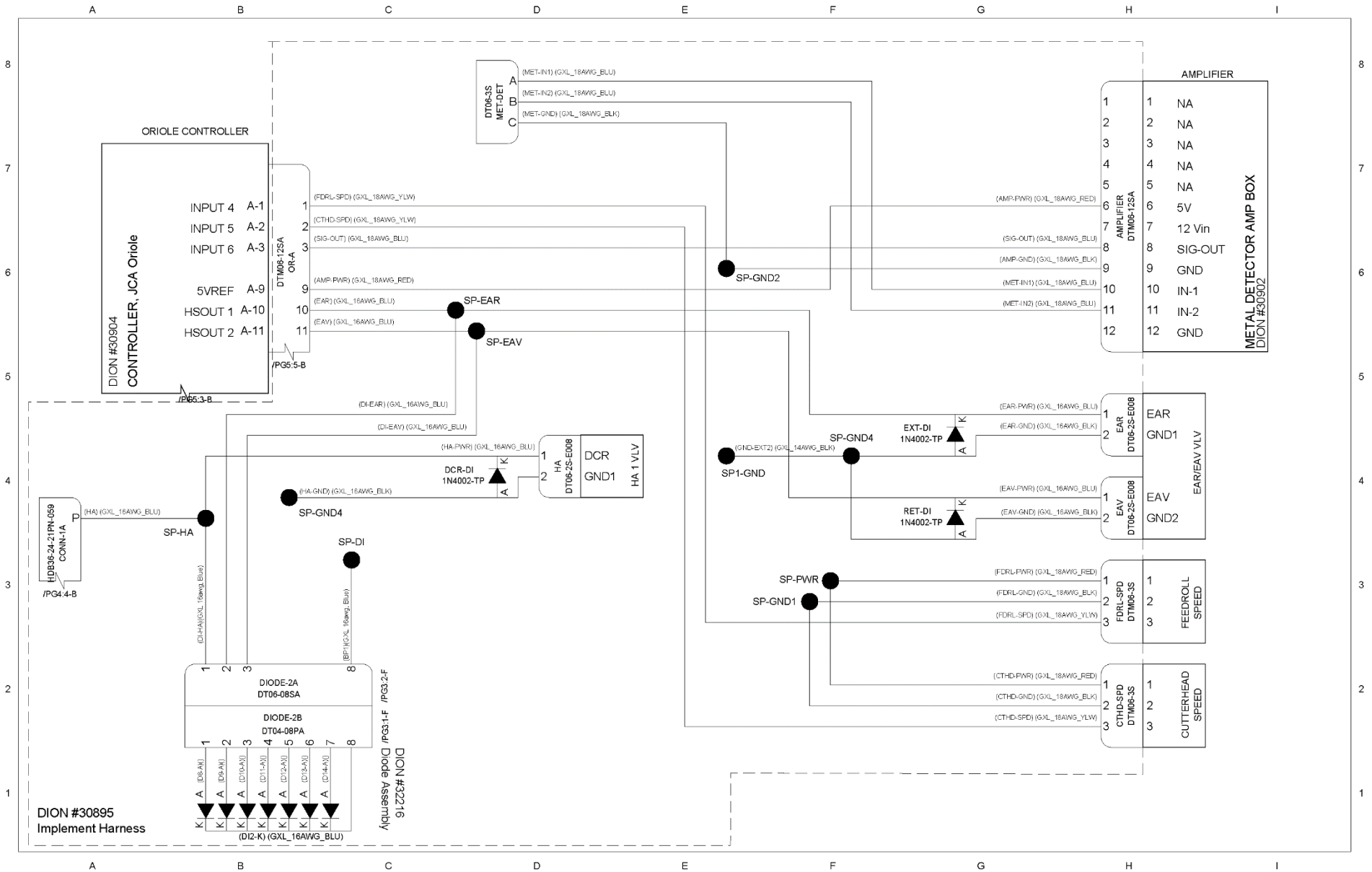

ELECTRICAL CIRCUITS

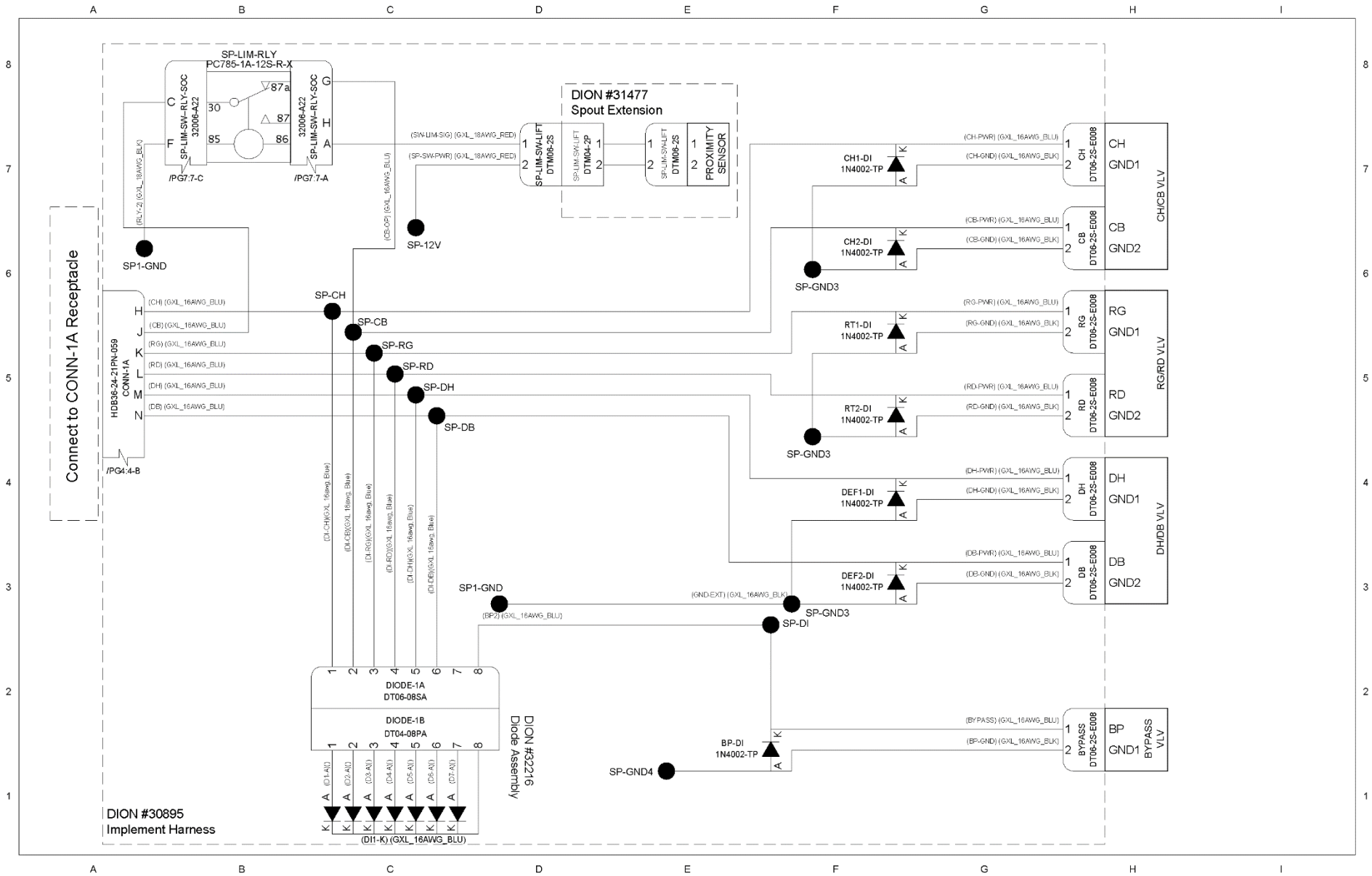

ELECTRICAL CIRCUITS

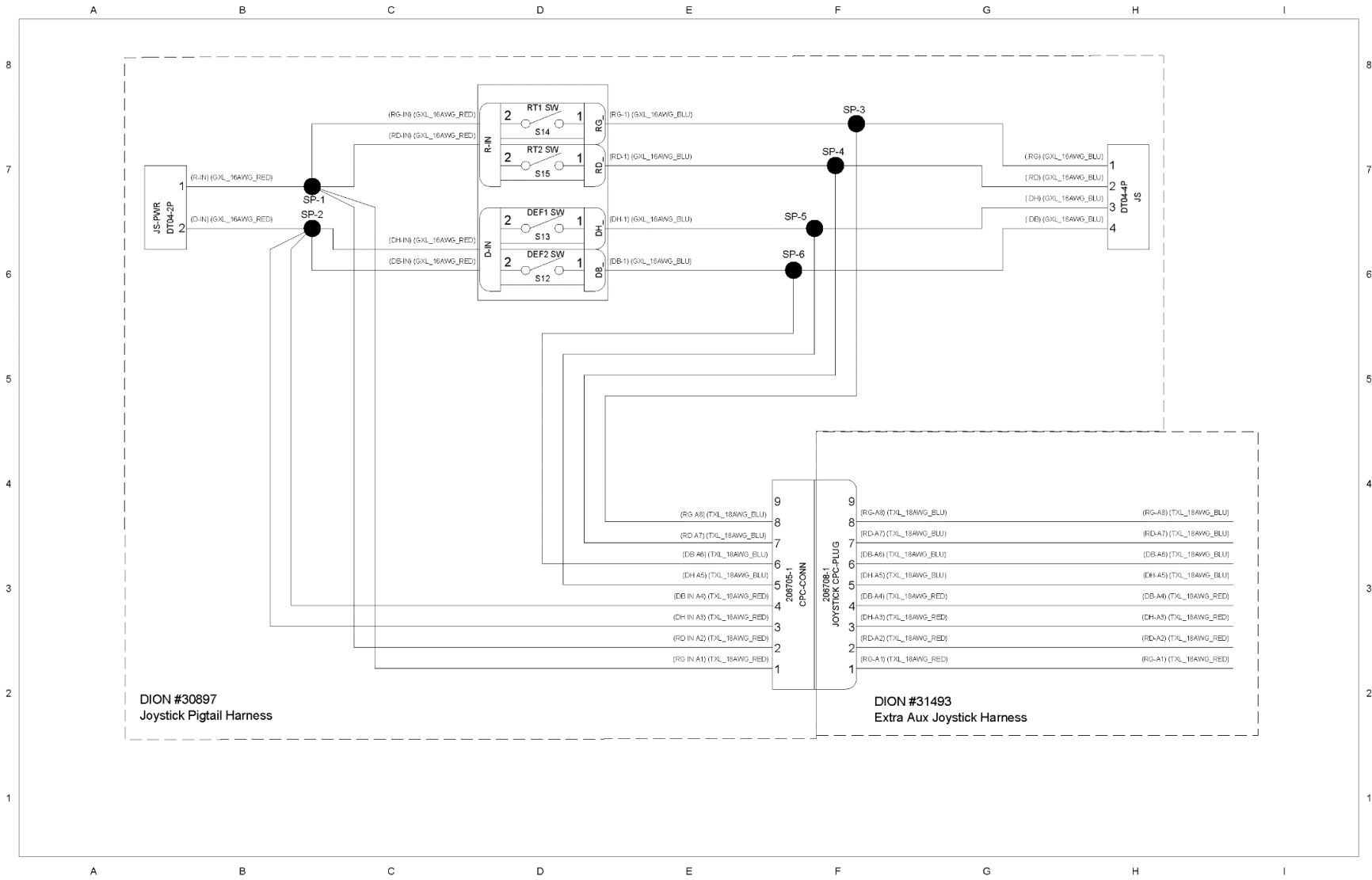

CHECKLIST

PRE-SEASON CHECKLIST

- Check condition of knives and shear bar. Check that knives and shear bar are set at “zero” clearance.
- Check tension of belts and chains. Make sure sheaves and sprockets are correctly aligned.
- Check all adjustable components for correct setting. Make sure adjustments are correct (accelerator, etc.)
- Check tire pressure. See specifications.
- Check wheel rim bolt torque. See Specifications.
- Perform complete lubrication and servicing of the machine. Make sure all grease fittings are in place and taking grease properly. Check gearbox and transmission fluid levels.
- Look for loose or missing bolts and parts.
- Run the machine in a stationary position at half-speed for a short period of time. Shut off tractor engine. Make sure all moving parts have stopped, then inspect bearings for over-heating, excessive wear, or loose flanges and lock collars.
- Check metal detection system for proper operation (if installed on machine). Always service metal detector when tractor engine is switched off.
- Make sure the proper operating adjustments have been made for current crop conditions.
- Make sure SMV emblem (Slow Moving Vehicle), transport lights and reflectors are in good condition and visible.
- Make sure all safety shields are installed. Review safety rules.
- Check parts for wear (paddles, accelerator bottom, spout liner, etc.).

DAILY CHECKLIST

- Check metal detection system. Always check metal detector system with the PTO disconnected.
- Remove all crop residue and wipe off oil and dirt.
- Lubricate and service the machine according to the servicing section.
- Check tension of belts and chains. Check all sheaves and sprockets for correct alignment.
- Check tire pressure. See Specifications.
- Make sure harvester is hooked to tractor correctly, and that the safety chain is safely installed. Make sure all controls are operable.
- Check that all electro-hydraulic functions are working properly.
- Sharpen knives and adjust shear bar once or twice a day

