



HORST WELDING
 8082 Rd 129
 Listowel, ON N4W 3G8
 Canada
 519-291-4162
 1-866-567-4162
 Fax 1-519-291-5388
sales@horstwelding.com
www.horstwelding.com

Operator's Manual

Keep this manual with the machine at all times

Running Gear

Wagon and Trailer Chassis



See complete
model listing
inside

CAUTION
Operational Hazard
 Personal Protection Equipment (PPE) is required when operating or maintaining this machine.



WARNING
Operational Hazard
 Ensure your towing vehicle has the weight capacity to tow and stop the loaded weight of this wagon.



CAUTION
Operational Hazard
 Wagon components have a maximum travel speed rating and affects payload. Potential for injury and damage if traveling above maximum travel speed rating.

MAXIMUM 50 km/h	MAXIMUM 32 km/h
30 mile/h	20 mile/h

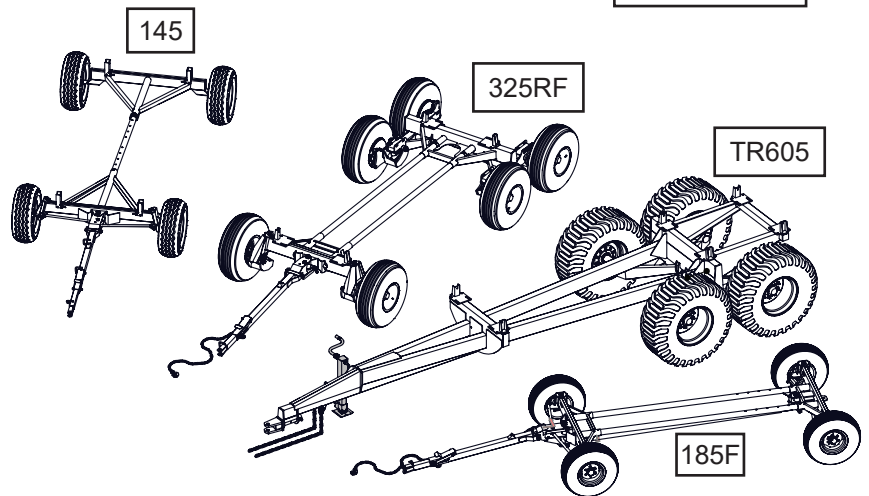

Do not attempt to operate the equipment without thoroughly reviewing this manual for safe and proper operation.

Notes

TABLE OF CONTENTS

Introduction	4	Field Operation	31
Safety	7	Operation Safety Checklist	31
Safety Messages	7	Prepare	31
Accident Prevention	8	Towing	32
Safety Guidelines	9	Before Towing:	32
Safety Training	9	Attach the Running gear	32
Operation Safety	10	Hydraulic Disc Brakes	33
Storage Safety	10	Hydraulic Brake Coupler Holder	33
Preparation	10	Wagon Trains	34
Trailer Jack	11	Storage	34
Brake Safety	11	Storage Safety Checklist	34
Maintenance Safety	11	Placing in Storage:	34
Hydraulic Safety	11	Service & Maintenance	35
Transport Safety	12	Maintenance Safety Checklist	35
Safety label replacement	12	Wheel Hubs:	35
Safety Labels	13	Inspect hubs monthly.	35
Safety Label Layout	14	Hub Components	35
Wagons	14	Repacking	35
Trailers	15	Wheel Bearing Preload	36
Specifications	16	Running Gear Components:	37
Components and Features	19	Wagon Models	37
Running Gear Wagon Series Components	19	Walking beam models	38
Running Gear Trailer Series Components	20	Rocking Bolster:	38
TR505 / TR605	20	TR505RF & TR605RF - Articulating Hitch	39
TR505RF / TR605RF	20	TR505 & TR605 - Pivoting Hitch	39
Product Features	21	TR505 & TR605 - Drop Leg Jack	40
Safety Chain:	21	TR505RF & TR605RF - Hydraulic Jack	40
Tongue Extension with auto lock:	21	Wheel Alignment - Wagons	41
Extendable Tongue:	21	Trailing adjustment - 185F	41
Swivel Hitch - TR505 / 605	22	Disc Brake Maintenance	42
Articulating Hitch - TR505RF / 605RF	22	Note: Initial Service:	42
Drop Leg Jack - TR505 / 605	22	Inspection	42
Hydraulic Jack - TR505RF / 605RF	23	Service	42
Bolsters	23	Surge Brake System Maintenance	43
Rocking Bolster:	23	Note: Initial Service:	43
Adjustable Reach Poles	24	Inspection	43
Road Flex Independent Suspension:	24	Service	43
Four Wheel Steer	25	Surge Brake Tongue	44
Optional Features	26	Brake Fluid	44
Hydraulic Surge Brakes	26	Bolt Torque Table	45
Hydraulic Disc Brakes	26	Wheel Torque Specification	46
Spring Balancer:	27	Tire Pressure	46
Digi-Star Scale System:	27	Trouble Shooting	47
Tongue Pull-out with auto lock:	27	Wagon / trailer	47
Tongue Pull-out Extension:	28	Brakes	48
Initial Setup	29	Payload and GVWR Chart	49
Installing Material Handling Platform	29	Index	55
Determine Safe Payload	29		
Installing the Platform	29		
Installing Digi Star Control Console	30		
Articulating Hitch Adjustment	30		

INTRODUCTION

Thank you for purchasing your new Horst Wagon or Trailer Chassis Running Gear.

Horst Wagons running gear has been designed and manufactured to give you many years of dependable service.

Features include industry leading tapered roller bearings on the king pins and automotive style ball joints. No-Sway trailing ensures that our wagons stay behind you and also provide years of hard working service.

ROAD FLEX running gear models use suspension blocks to help eliminate bumps and vibrations when traveling down the road or through the field. ROAD FLEX suspension not only reduces the stress from towing heavy loads but also provides increased stability to Horst wagons

Keep this manual available for reference whenever this product is being handled or used. Provide this manual to any new owners and/or operators for training and review.

Safe, efficient and trouble free operation of your Horst wagon requires that you or any other person, who will be assembling, operating, maintaining or working with this product, are required to read and completely understand the information and instructions contained in this manual. To avoid component failure and maintain complete control and stability at all times do not exceed GVWR gross vehicle weight rating or travel speed rating of the components: **see 'Payload and GVWR chart' at the back of this manual.**

If anyone does not fully understand every part of this manual, please obtain further assistance by contacting the dealer from which this product was purchased or by contacting Horst Welding with the information listed on the cover of this manual.

Keep this operators manual available for reference by the operator and to pass on to new owners and/or operators.

Assembly may be required depending on how you purchased your wagon. Follow the assembly procedures as outlined in the assembly manual.

This manual covers these models:

4-Wheel Wagon	6-Wheel Wagon	8-Wheel Quad Steer Wagon	Trailer Chassis
145 (8 ton)	245 (12 ton)	208 Quad (16 ton)	TR505 (20 ton)
185 (10 ton)	265 (14 ton)	308 Quad (20 ton)	TR605 (24 ton)
185F (6 ton)	325 (18 ton)	608 Quad (40 ton)	
205 (12 ton)	505 (22 ton)		
275 (14 ton)	605 (30 ton)		
285 (15 ton)			
365 (20 ton)			
365E (20 ton)			
485 (24 ton)			



4-Wheel Wagon	6-Wheel Wagon	8-Wheel Quad Steer Wagon	Trailer Chassis
185RF (10 ton)	325RF (18 ton)	308RF (20 ton)	TR505RF (20 ton)
205RF (12 ton)	505RF (22 ton)		TR605RF (24 ton)
285RF (15 ton)			
365RF (20 ton)			
485RF (24 ton)			

GENERAL INFORMATION

The purpose of this manual is to assist you in safely operating and maintaining your Horst wagon or trailer chassis. Read this manual carefully to obtain valuable information and instructions that will help you achieve safe and dependable service. The illustrations and data used in this manual were current at the time of printing, but due to possible engineering and/or production changes, this product may vary slightly in detail. Horst Welding reserves the right to update and/or change components as necessary without notification.

In this manual the Horst running gear series may be referred to as 'implement', 'wagon', 'trailer', 'rolling chassis' or 'running gear'

- **Tractor** refers to any tow vehicle towing a Horst wagon.
- **Travel speed rating** refers to the maximum speed Horst running gear components are designed for. (see 'Payload and GVWR Chart' at the back of this manual)
 - Travel speed rating - low max: 30 km/h (20 mile/h),
 - Travel speed rating - high max: 50 km/h (30 mile/h)
- **Maximum road speed** refers to the 40 km/h (25 mile/h) for slow moving vehicles displaying a **SMV**, or in the U.S. high speed vehicles towing faster than 40km/h (25 mile/h) to 65 km/h (40 mile/h) displaying a **SMV & SIS**.

INTENDED USE

The Horst Wagons running gear series chassis is designed to be towed with an agricultural tractor and intended to be used as a rolling chassis for material handling, outfitted by the end user or OEM manufacturer with a flat deck or containment unit, constructed to be within the gross vehicle weight rating (GVWR) of the running gear model as configured from Horst Wagons.

PARTS LIST

The parts lists for these products can be found online. Visit horst wagons.com and click on the PARTS tab to be directed to our online parts catalogue.



CALIFORNIA PROPOSITION 65

This warning is required by California Proposition 65 (Prop 65), which is meant to notify California residents of exposures to Prop 65-listed chemicals. For more information go to 'www.P65Warnings.ca.gov.'



SLOW MOVING VEHICLE SIGN (SMV)

Vehicle Towed Implement Traveling Less Than 40 km/h (25 mile/h)

This standard is recognized and part of Canadian Provincial Transport Ministries laws & regulations and U.S. Federal Regulations.

The purpose of the slow-moving vehicle (SMV) sign is to warn other road users that the vehicle towed implement displaying the sign is traveling slower than the normal speed of traffic up to a maximum road speed of 40 km/h (25 mile/h). Horst Wagons are subject to a travel speed rating - low: maximum 30 km/h (20 mile/h). (see Payload and GVWR Chart)

Ensure the sign is in place whenever transporting on a public road.



SPEED IDENTIFICATION SYMBOL (SIS)

High Speed Tractors Traveling Faster Than 25 mile/h

The SIS standard is part of the US Federal Regulation 49CFR Part 562. (Does not apply in Canada)

The purpose of the Speed Identification Symbol (SIS) standard is primarily to identify equipment that has been specifically designed for ground speeds greater than 25 mile/h but under 40 mile/h, when operating or traveling on public roads. The SIS also identifies the farm machineries' maximum safe travel speed rating. Horst Wagons are subject to a travel speed rating - high: maximum 30 mile/h. (see Payload and GVWR Chart)

The SIS needs to be used in conjunction with the SMV sign.

SERIAL NUMBER LOCATION

The serial number for your Horst Wagon running gear is located on the back top right side of the rear axle. Please record your serial number here as a handy reference. In case of warranty issues, your dealer will ask for the serial to verify your warranty.

Model Number _____

Serial Number _____

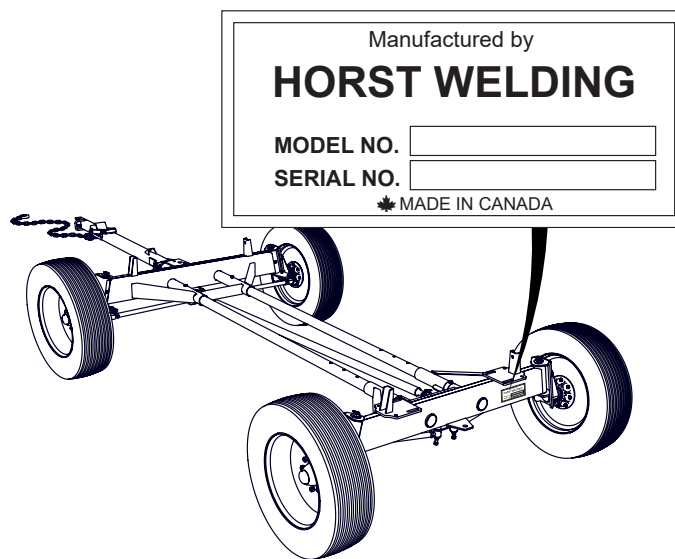

SAFETY



This Safety Alert Symbol means:
ATTENTION!
BECOME ALERT!
YOUR SAFETY IS INVOLVED!

The Safety Alert symbol identifies important safety messages on the implement and in the manual. When you see this symbol, read and understand the message, be alert to the potential hazard in the message. Follow the instructions in the safety message.

SAFETY MESSAGES

Throughout this manual, the terms **DANGER, WARNING, CAUTION** and **IMPORTANT** are used to indicate the degree of hazard to personnel if proper safety procedures and guidelines are not followed. The appropriate term for each message has been selected using the following guide-lines:

DANGER - Indicates an imminently hazardous situation that, if not avoided, will result in death or serious injury, and includes most extreme situations typically for implement components which, for functional purposes, cannot be guarded.

WARNING - Indicates a potentially hazardous situation that, if not avoided, could result in death or serious injury, and includes hazards that are exposed when guards are removed. It may also be used to alert against unsafe practices.

CAUTION - Indicates a potentially hazardous situation that, if not avoided, may result in minor or moderate injury. It may also be used to alert against unsafe practices.

IMPORTANT - Indicates a situation that could result in damage to the implement or other property.

In the owners manual, when a hazard is present you will see a safety message box. The box may contain:

- The safety alert symbol,
- The safety term
- The safety hazard
- The safety hazard explanation

When applicable you may also see the appropriate safety label displayed with the message, as shown below.

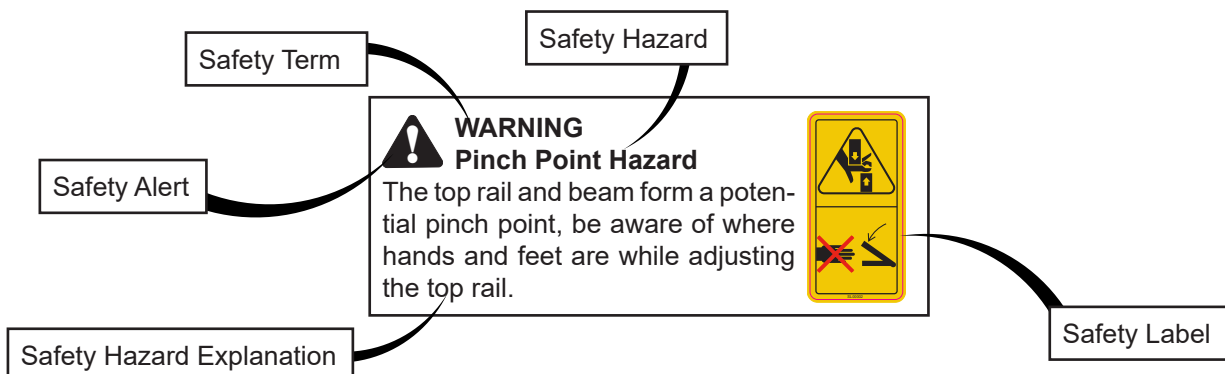

The safety information given in this manual does not replace any safety codes, insurance needs, government and local laws.

ACCIDENT PREVENTION

ACCIDENTS CAN BE PREVENTED WITH YOUR HELP!

YOU are responsible for the SAFE operation and maintenance of your implement. **YOU** must ensure that you and anyone else who is going to use, maintain or work around the implement be familiar with the work and maintenance procedures and related SAFETY information contained in this manual. This manual will take you step-by-step through your working day and alerts you to all good safety practices that should be used.

Remember, **YOU** are the key to safety. Good safety practices not only protect you but also the people around you. Make these practices an effective part of your day to day work habits. Be certain that EVERYONE using this implement is familiar with the recommended maintenance and work procedures and follow all the safety precautions. Most accidents can be prevented. Do not risk injury or death by ignoring good safety practices.



The best accident prevention is a careful operator.

Horst Welding and your dealer ask that YOU be that careful, responsible equipment operator.

YOU ARE THE KEY TO SAFETY:



• Familiarize yourself, and anyone else who will operate, maintain, or work around this product, with the safety and operation information contained in this manual.

- Read and understand the safety labeling which appears on the implement.
- Have a first-aid kit available for use should the need arise and know how to use it. 
- Pay attention to the job at hand. Do not let your mind lose concentration on what you are doing. No accident prevention program can be successful without the wholehearted cooperation of the person who is directly responsible for the operation of the implement.
- Have a fire extinguisher available for use should the need arise and know how to use it. 
- Reduce the risk of injury or death by following all safety precautions and by using good safety practices.
- Accidents can to be prevented: that prevention will come from equipment operators who accept their complete responsibility and anticipate the results of their actions.

- Never exceed the limits of the implement. Safety of the operator and safe operation are the main concerns in designing a safe product, however ignoring implement specifications by the operator can result in a accident which could have been prevented.



- Do not allow riders on the implement, loaded or empty.
- Do not operate this implement under the influence of drugs or alcohol.
- Be responsible for the SAFE operation and MAINTENANCE of YOUR implement.
- Wear appropriate personal protective equipment (PPE). This list includes but is not limited to:

- Hard hat
- Heavy gloves
- Hearing Protection
- Protective foot wear
- Protective eye wear
- Safety Vest



SAFETY GUIDELINES

Safety of the operator and bystanders is one of the chief concerns in developing and designing equipment. However, every year many accidents occur which could have been avoided by a few seconds of thought and a more cautious approach to handling equipment.

You, the operator, can avoid many accidents by observing the following precautions in this section. To avoid personal injury or death, study the following precautions and insist those working with you, or for you to follow them.

In addition to the design and configuration of this implement, including safety labels and safety devices, hazard control and accident prevention are dependent upon the awareness, concern, and proper training of personnel involved in the operation, transport, maintenance, and storage of the implement. Refer also to safety messages and operation instruction in each of the appropriate sections of the tractor and implement manuals. Pay close attention to the safety labeling affixed to the implement.

1. In order to provide a better view, certain illustrations in this manual may show an assembly with a safety device removed. However, equipment should never be used in this condition. Keep all safety devices in place, if removal becomes necessary for repairs, replace the device prior to use.
2. Replace any safety label or instruction sign that is unreadable or is missing. Location of safety signs is indicated in this manual.
3. Never use alcoholic beverages or drugs which can hinder alertness or coordination while using this implement. Consult your doctor about using this implement while taking prescription medications.
4. Under no circumstances should young children be allowed to work with this implement.
5. This implement is dangerous to persons unfamiliar with its operation. Do not allow persons to use or assemble this unit until they have read this manual and have developed a thorough understanding of the safety precautions and of how it works. Review the safety instructions with all users annually.
6. If the elderly are assisting with work, their physical limitations need to be recognized and accommodated. Assistants should be a responsible, properly trained and physically able person familiar with machinery and trained in this implement's operations.
7. Never exceed the limits of the implement. If its ability to do a job, or to do so safely, is in question - DON'T TRY IT.
8. Do not modify the implement in any way. Unauthorized modification may result in serious injury or death and may impair the function and life of the implement.

SAFETY TRAINING

A person who has not been trained or has not read and understood all use and safety instructions is not qualified to use the implement. An untrained operator exposes himself and bystanders to possible serious injury or death.

- Train all new personnel with the instructions alongside the implement. Be certain only a properly trained and physically able person will use the machinery.
- Working with unfamiliar equipment can lead to careless injuries. If this implement is used by any person other than yourself, or is loaned or rented, it is the implement owner's responsibility to make certain that the operator, prior to using:
 - Reads and understands the operator's manuals.
 - Is instructed in safe and proper use of the implement
 - If the elderly are assisting with the work, their physical limitations need to be recognized and accommodated.
- Operators or maintenance personnel who are not fully able to read and understand this manual should not operate or work on the implement:
- Make certain that all operators and maintenance personnel have complete understanding of the full and exact contents of this manual and safety labeling.
- ALL information contained in this manual and labeling on the implement must be conveyed CLEARLY and FULLY, in order to be able to operate safely and knowledgeably.
- Review the implement and instructions regularly with existing workers.

OPERATION SAFETY

1. NEVER allow helpers or bystanders under or near the machine.
2. Make sure that the load is fastened securely to the implement before moving.
3. Inspect all fastening devices, do not use if worn or damaged.
4. Use a high strength hitch pin to hitch the implement to towing unit,
5. Make sure that everyone is clear before moving the implement. NEVER position yourself between the towing unit and the implement.
6. Do not permit riders while transporting this implement with or without a load.
7. Where possible, avoid operating near ditches, embankments and holes.
8. Loading or unloading an unhitched implement, be sure to properly block or chock the wheels to prevent the implement from moving.
9. Inspect rims for dents or damage, check wheel lugs and tighten if required.
10. Secure the hitch with the safety chain. Replace the safety chain if one or more links or end fittings are broken, stretched or otherwise damaged or deformed
11. Ensure there is adequate lighting while working at dusk or after sunset.
12. Do not park an unhitched wagon on any grade without applying wheel chocks.

STORAGE SAFETY

1. Store the safety chain by securing it around the tongue.
2. Store the unit in an area away from human activity.
3. Do not allow children to play on or around the stored implement.
4. Store the unit in a dry, level area. Cover if stored outside.
5. Guard any sharp corners.
6. Ensure components and safety features are not damaged and in good condition before storing the implement. Make repairs now to be ready for the following season.
7. Secure the implement to prevent unwanted movement.

PREPARATION

1. Inspect implement for shipping damage. If damage does exist, do not use. Notify your dealer immediately to have damaged parts replaced or repaired.
2. Assembly may be required depending on how you purchased your equipment. Follow the assembly procedures as outlined in the assembly manual, ensure all hardware is secure.
3. When traveling on public roads ensure rear facing safety signs are installed:
 - Canada: SMV (slow moving vehicle) sign
 - USA: SMV (slow moving vehicle) emblem and if required SIS (speed identification symbol) sign.
4. Ensure safety chain, pins, straps, tires are not damaged and in good condition.
5. Inspect all fasteners that they are not lose or missing. Ensure fasteners and wheel bolts are torqued according to the torque chart at the back of this manual
6. If traveling at night, ensure provincial state and local laws lighting requirements have been met, check implement lighting
7. Ensure that all applicable safety decals are installed and legible.
8. Personal protection equipment (PPE) including hard hat, safety glasses, safety shoes, and gloves are recommended during assembly, installation, operation, adjustment, maintaining, repairing, removal, cleaning, or moving the unit. Do not allow long hair, loose fitting clothing or jewelry to be around equipment.
9. When not attached to the towing unit, block and chock the wheels to prevent movement.
10. Check alignment of wheels, realign the wheels if needed.
11. Check and Inflate all tires to recommended PSI.
12. Hydraulic brakes: check connection and test function of the brakes.
13. Surge brakes: check brake reservoir level and test function of the brakes.

TRAILER JACK

1. Do not alter or modify the jack.
2. Never position any part of body under any part of the jack or the load being supported.
3. Fully retract the jack before towing.
4. When using the drop leg, make certain the drop leg pin is fully inserted before using the jack.
5. Secure the trailer from rolling (by blocking wheels) when operating jack or coupling trailer.
6. Never exceed maximum rated capacity. 12000 lb static capacity.
7. Jack is designed for vertical loading. Excessive side forces may cause jack failure and must be avoided.
8. Never attempt to adjust the drop leg when the jack is under load.
9. Keep clear of pinch point at drop leg pin. The spring loaded drop leg will naturally retract very quickly.
10. Keep clear of leg pin holes in drop leg.
11. Always replace bent, broken, or worn parts before using the jack.

BRAKE SAFETY

1. Good brake maintenance is your responsibility, Poor maintenance is an invitation to trouble.
2. Follow the maintenance schedule and have a mechanic inspect the entire brake system.
3. Brakes should be inspected after the first 320 km (200 miles) of operation.
4. Surge brake system: regularly check:
 - Brake shoes and drum for wear
 - Brakes function properly, and apply evenly
 - Hoses and lines for damage or wear.
 - Break - Away system (if installed)
 - Brake fluid reservoir level
5. Hydraulic brake system: regularly check:
 - Hoses and lines for damage or wear.
 - Correct couplers are used
 - Couplers for damage or wear,
 - Couplers are clean and seated securely
 - Brake pads, calliper and rotor for wear.
 - Brakes function properly, and apply evenly
 - Break - Away system (if installed)
6. Avoid aggressive braking which results in wheel lock up and sliding, Wheel lock up can cause a dangerous loss of control and result in personal injury or death.
7. Inspect brake fluid, contaminated brake fluid in system could plug fittings and render brakes inoperative resulting in personal injury or death.

MAINTENANCE SAFETY

1. Good maintenance is your responsibility, follow the maintenance schedule. Poor maintenance is an invitation to trouble.
2. Follow good shop practices.
 - Keep service area clean and dry.
 - Be sure electrical outlets and tools are properly grounded.
 - Use adequate light for the job at hand.
3. Never work under or around an unhitched implement unless it is blocked and chocked securely.
4. Use personal protection equipment (PPE) such as eye, hand and hearing protectors.
5. Never adjust, service, clean or lubricate the implement until all power is shut off when attached to the tow unit.
6. Ensure hardware is torqued according to the torque chart at the back of this manual.
7. Disconnect battery ground cable before servicing any part of the electrical system.

HYDRAULIC SAFETY

(Brake equipped wagons)

1. Make sure that all the components in the hydraulic system are kept in good condition and are clean.
2. Before applying pressure to the system, inspect for leaks at all components, and that lines, hoses , connections and couplings are not damaged and leak free.
3. Do not attempt any makeshift repairs to the hydraulic lines, fittings or hoses by using tapes, clamps or cements. The hydraulic system operates under extremely high pressure. Such repairs will fail suddenly and create a hazardous and unsafe condition.
4. Wear proper hand and eye protection when searching for a high pressure hydraulic leak. Use a piece of wood or cardboard as a backstop instead of hands to isolate and identify a leak.
5. If injured by a concentrated high-pressure stream of hydraulic fluid, seek medical attention immediately. Serious infection or toxic reaction can develop from hydraulic fluid piercing the skin surface.
6. Relieve pressure on hydraulic system before maintaining or working on system.
7. All hydraulic work must be done by qualified personnel

TRANSPORT SAFETY

1.  Towing the wagon: Check the 'Equipment Matching' section to find minimum tractor weight required to tow a full load for your wagon.
2. Train Configuration: the maximum allowable number of wagons is two in a train configuration. Ensure your towing vehicle has the weight capacity to tow and safely stop the loaded weight of the wagon train.
3. Up to 30 km/h (20mile/h) do not tow single or train loads more than 1.5 times the tractor / tow vehicle weight. Unbraked towed loads that are too heavy for the tow vehicle and can cause loss of control when braking.
4. At 30 km/h (20mile/h) up to 40 km/h (25mile/h) do not tow single or train loads more than 0.6 times the tractor / tow vehicle weight. Unbraked towed loads that are too heavy for the tow vehicle and can cause loss of control when braking.
5. At 40 km/h (25 mile/h) up to 50 km/h (30mile/h) do not tow single or train loads more than 0.6 times the tractor / tow vehicle weight. Brakes are recommended on wagon. Braked towed loads that are too heavy for the tow vehicle can cause loss of control when braking.
6. Component capacity: components are rated for speed and capacity. Components have a travel speed rating. See 'Payload and GVWR chart' to determine payload at speed of your model wagon.
7. **In Canada** running gear on public roads displaying an SMV (slow moving vehicle) sign are subject to a maximum speed is 40 km/h. **Horst wagons have a travel speed rating - low maximum of 30 km/h (20 mile/h).**
8. **In USA** running gear on public roads displaying an SMV (slow moving vehicle) sign are subject to a maximum speed is 25 mile/h. **Horst wagons have a travel speed rating - low maximum of 20 mile/h.** When equipped with an appropriate SIS (speed identification symbol) maximum speed on public roads is 40 mile/h. **Horst wagons have a travel speed rating - high maximum of 30 mile/h.**
9. Brakes (if installed) see 'Brake Safety'.
 - Ensure brakes are working
 - Test the function of the break - away safety system, if installed.
10. Test the function of the implement lighting if installed.
11. Hitch pin - grade 5
 - Check the hitch pin is appropriate diameter and length for the hitch
 - If the pin is damaged, replace it
 - Secure with a lynch pin
12. Safety chain
 - Do Not allow the chain to drag, string the safety chain thru the chain support at the clevis.
 - Do Not use any other implement component as an attaching point
 - Secure chain on the tow vehicle at the towing attach point. (chain loops)
 - Do Not allow more slack than necessary for articulation.
 - Replace the safety chain if one or more links or end fittings are broken, stretched or otherwise damaged or deformed.
13. Check tires before proceeding:
 - Inflation - correct pressure
 - Tread - unusual wear, exposed cord
 - Rims - damaged or bent
 - Wheel bolts - all secure, not loose
 - Replacement tires must be same type and rating
14. Just before transport, perform a circle check to ensure everything is secure and safe.
15. Be sure all markers required by local traffic regulations are in place, clean and working.
16. Lighting is not required for daytime transport, however generally lighting is required one-half hour before sunset to one-half hour after sunrise and at any other time when there is insufficient light or unfavourable atmospheric conditions.
17. Reduce speed when turning, crossing slopes and rough, slick or muddy surfaces.
18. Stopping distance of towed loads increase with speed, weight and on slopes. Towed loads that are too heavy for the tow vehicle or are towed too fast can cause loss of control. Consider total weight: implement and its load.

SAFETY LABEL REPLACEMENT

1. Be sure that the installation area is clean and dry.
2. Be sure temperature is above 50°F (10°C).
3. Determine exact position before you remove the backing paper.
4. Remove the smallest portion of the split backing paper.
5. Align the sign over the specified area and carefully press the small portion with the exposed sticky backing in place.
6. Slowly peel back the remaining paper and carefully smooth the remaining portion of the sign in place.
7. Small air pockets can be pierced with a pin and smoothed out using the piece of sign backing paper.

SAFETY LABELS

Safety labeling is an important part of the overall safe use of the implement. Safety labeling alerts and warns against potential injury or death, and is important to follow these points to help keep your implement safe for you and others who may be using it.

- Keep safety signs clean and legible at all times.
- Replace safety signs that are missing or have become illegible.



Caution: read and understand ALL safety and operating instructions in the manual, read and understand ALL safety labels located on the machine. The most important safety device on this equipment is an informed SAFE operator.



Warning: Before transport always have the safety chains attached, and a correct sized hitch pin installed and secured. Accidental implement disconnection could result in death or serious injury and or implement damage.



Caution: Hydraulic fluid is under pressure, be aware that hydraulic leaks could develop with out warning. Do not check for leaks with your hand or fingers while the system is pressurized, serious injury could result. Possible burns or poisoning from pressurized fluid injection.



Warning: BE AWARE of minimum tractor weight required to tow a full capacity unbraked load. Check the specification chart for your wagon's minimum tractor weight.

Do not tow single or train loads more than 1.5 times the tractor weight. Ensure your towing vehicle has the weight capacity to tow and safely stop the loaded weight of the wagon or wagon train.

Unbraked towed loads that are too heavy for the tractor can cause loss of control when braking and may cause injury or death.

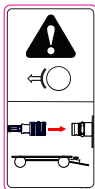

Caution: Attach the hydraulic brake hose coupler to the coupler holder when the brake system is not in use while the towing or when parked. Pressure may build up in the brake circuit causing unwanted application of the brakes and loss of control if not connected to the coupler holder.

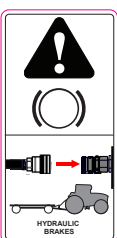

Caution: Attach the hydraulic brake hose coupler to the brake port outlet on the tractor when hauling the trailer / wagon with a load. Do not attempt to attach this brake coupler to anything other than the brake outlet on the tractor.

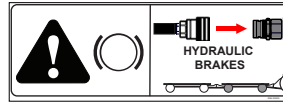

Caution: A hydraulic coupler outlet for brakes is included on the rear wagon axle for connecting braked wagons in a train configuration,

Do not attempt to use this outlet for anything other than braking.

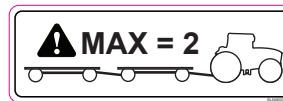

Caution: Wagon trains must be limited to a maximum of two wagons when fully loaded with a suitable capacity tractor.

Towing more than two fully loaded wagons is dangerous and could result in death or serious injury and or implement damage.



Important: Wagon components require lubrication every 1000 hrs or Annually. Failure to perform regular maintenance could result in damage to the implement or other property. See owners manual maintenance section.



Caution: Wagon components are rated at 50 km/h (30 mile/h) maximum speed. Potential for injury and damage if traveling above maximum travel speed rating. Weight capacity is lower at speeds above 32 km/h (20 mile/h) See Payload and GVWR Chart in owner manual.



Caution: Block or chock the wheels. Loading or unloading the wagon presents a potential unintentional movement hazard. Chock wheels when loading or unloading or storing the wagon.



Caution: Personal Protection Equipment (PPE) is required when operating or maintaining this machine. Failure to wear PPE will result in personal injury.



Caution: check wheel lugs at each trip, See torque specification chart at the back of this manual.

Note: Safety labeling is dependant on wagon model. Not all safety labels appear on all models

TRAILERS

Safety signs and locations on the equipment are shown in the illustrations below. Label locations are similar for all models listed, unless otherwise indicated.

Good safety practice requires that you familiarize yourself with the label and the safety message it is delivering. Be aware of the equipment or particular equipment feature that requires your SAFETY AWARENESS.

For Wagon Models:

TR505 (20 ton)

TR605 (24 ton)

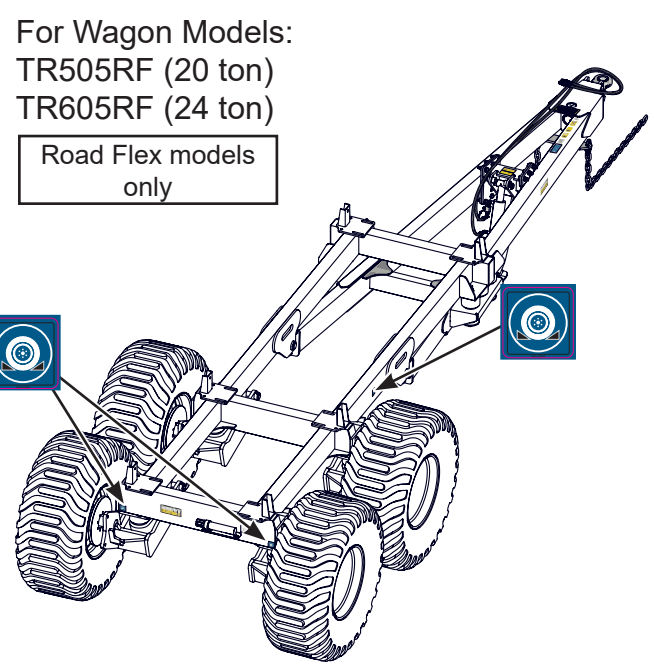
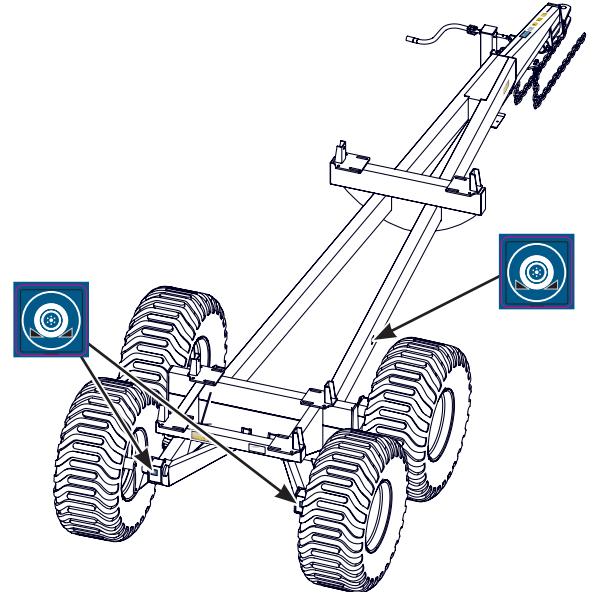
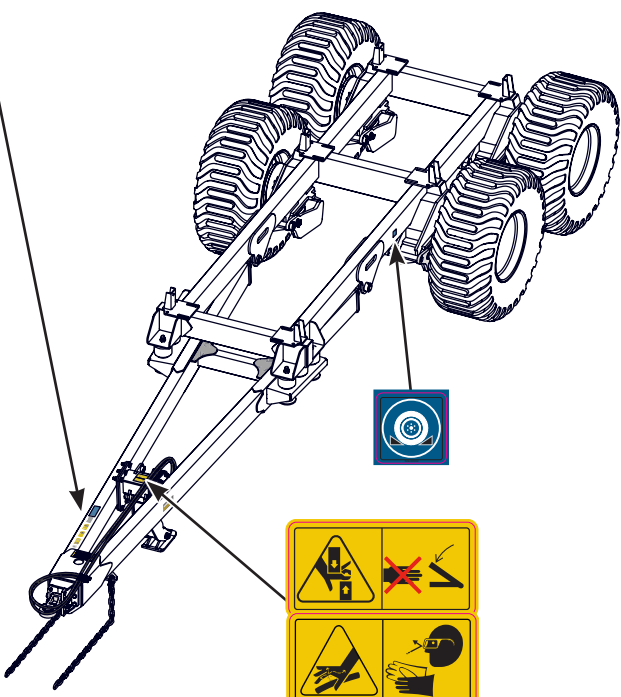
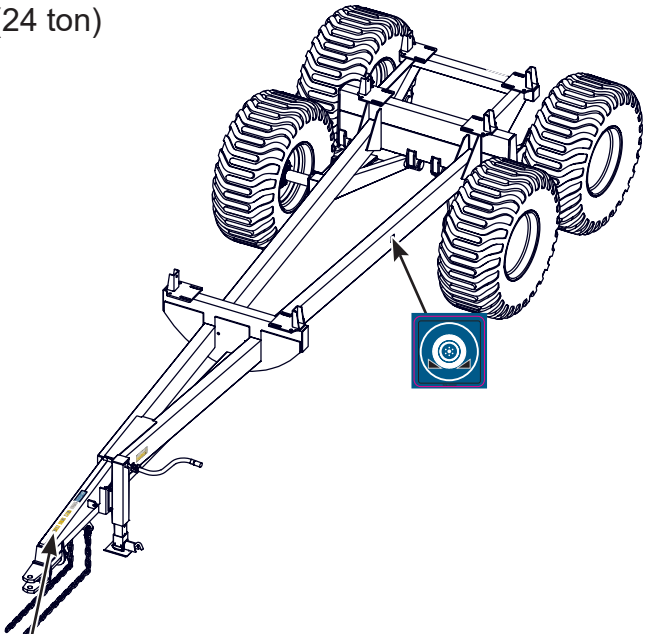

For Wagon Models:
TR505RF (20 ton)
TR605RF (24 ton)
Road Flex models only

SPECIFICATIONS

Refer to the specification chart below for your model running gear. Please note: travel speed above 30 km/h (18.6 mile/h) in some cases reduces payload of the wagon.

For wagon GVWR, payload and travel speed see the 'Payload and GVWR' chart at the back of this manual.

Standard Features
Taper Roller bearing in steering gear
Extendable Tongue
Greasable Automotive Style Tie Rod Ends
Tongue Retract, with Auto Relock
Adjustable Wheel Base

Running Gear Specifications	Approx Weight (less tires & Wheels)	Hubs: Bolt / Stud	Safety Chain	Axle Beam Height x Width x Thickness	
				Front Axle	Rear Axle
4 Wheel					
145 (8 ton)	535	6 bolt	3/8" GR. 70	5.5 x 3 x .188 WALL	5.5 x 3 x .188 WALL
185 (10 ton)	740	6 bolt	3/8" GR. 70	6 x 3 x .250 WALL	6 x 3 x .250 WALL
185F (6 ton)	1,000	6 bolt	3/8" GR. 70	6 x 3 x .250 WALL	6 x 3 x .250 WALL
205 (12 ton)	845	8 bolt	3/8" GR. 70	7 x 3 x .250 WALL	7 x 3 x .250 WALL
275 (14 ton)	1,015	8 stud	1/2" GR. 69	8 x 3.5x .250 WALL	8 x 3.5x .250 WALL
285 (15 ton)	1,445	8 stud	1/2" GR. 70	8 x 4 x .250 WALL	8 x 4 x .188 WALL
365 (20 ton)	1,595	8 stud	1/2" GR. 70	10 x 4 x .250 WALL	10 x 4 x .188 WALL
365E (20 ton)	1,495	8 stud	1/2" GR. 70	10 x 4 x .250 WALL	10 x 4 x .188 WALL
485 (24 ton)	2,210	10 stud	5/8" GR. 70	10 x 4 x .500 WALL	10 x 4 x .188 WALL
4 Wheel Road Flex					
185RF (10 ton)	1,150	6 bolt	3/8" GR. 70	6 x 3 x .250 WALL	6 x 3 x .250 WALL
205RF (12 ton)	1,270	8 bolt	3/8" GR. 70	7 x 3 x .250 WALL	7 x 3 x .250 WALL
285RF (15 ton)	3,085	8 stud	1/2" GR. 70	8 x 4 x .250 WALL	8 x 4 x .188 WALL
365RF (20 ton)	3,505	8 stud	1/2" GR. 70	10 x 4 x .250 WALL	10 x 4 x .188 WALL
485RF (24 ton)	4,370	10 stud	5/8" GR. 70	10 x 4 x .500 WALL	10 x 4 x .375 WALL
6 Wheel					
245 (12 ton)	985	6 bolt	3/8" GR. 70	6 x 3 x .250 WALL	6 x 3 x .250 WALL
265 (14 ton)	1,155	8 bolt	1/2" GR. 70	7 x 3 x .250 WALL	7 x 3 x .313 WALL
325 (18 ton)	1,495	8 stud	1/2" GR. 70	8 x 3.5x .250 WALL	8 x 4 x .250 WALL
505 (22 ton)	2,405	8 stud	1/2" GR. 70	10 x 4 x .250 WALL	10 x 4 x .375 WALL
605 (30 ton)	3,295	10 stud	5/8" GR. 70	10 x 4 x .500 WALL	10 x 4 x .500 WALL
6 Wheel Road Flex					
325RF (18 ton)	2,185	8 stud	1/2" GR. 70	8 x 3.5x .250 WALL	8 x 4 x .250 WALL
8 Wheel					
208 Quad (16 ton)	1,675	8 bolt	1/2" GR. 70	7 x 3 x .250 WALL	7 x 3 x .313 WALL
308 Quad (20 ton)	2,135	8 stud	1/2" GR. 70	8 x 3.5x .250 WALL	8 x 4 x .250 WALL
608 Quad (40 ton)	3,020	10 stud	3/4" GR. 70	10 x 4 x .500 WALL	10 x 4 x .500 WALL
8 Wheel Road Flex					
308RF (20 ton)	3,030	8 stud	1/2" GR. 70	8 x 3.5x .250 WALL	8 x 4 x .250 WALL
Trailer Chassis					
TR505 (20 ton)	2,700	8 stud	1/2" GR. 70	n/a	n/a
TR605 (24 ton)	3,775	10 stud	5/8" GR. 70	n/a	n/a
Trailer Chassis Road Flex					
TR505RF (20 ton)	5,270	8 stud	1/2" GR. 70	n/a	n/a
TR605RF (24 ton)	5,885	10 stud	5/8" GR. 70	n/a	n/a

ASSEMBLY & INSPECTION

Depending on how you ordered your machine, assembly may be required. To assemble your implement please find the Assembly Instructions Manual that came with your wagon

Before beginning assembly or putting the wagon into service the first time, inspect the machine for shipping damage. If damage does exist, do not use. Notify your dealer immediately to have damaged parts replaced or repaired.

If you received your machine assembled, inspect machine for damaged or loosened parts. If damaged parts exist, do not use. Notify your dealer immediately to have affected parts replaced or repaired.

EQUIPMENT MATCHING

To insure the safe and reliable operation of the Horst wagon, it is necessary to match the tractor with the wagon. Consult your tractor owners manual for specifications and use the 'Minimum Tractor Weight Chart' as a guide for your wagons minimum tractor weight to ensure your tractor capacity matches the wagons capacity.

Operating the wagon above the 30 km\h (20 mile\h) speed may require a reduction in payload, and wagon brakes are recommended. (see the 'Payload and GVWR chart' at the back of this manual)

Operating the wagon above 30 km\h (20 mile\h) without payload reduction or wagon brakes is a safety hazard, and may cause personal injury and damage to the wagon and will void the warranty.

Minimum Tractor Weight Requirement	
Wagon Model	Minimum tractor size required LBS
185F	8000
145	10667
185	13333
185RF	13333
205	16000
205RF	16000
245	16000
275	18667
265	18667
285	20000
285RF	20000
208 Quad	21333
325	24000
325RF	24000
365	26667
365E	26667
365RF	26667
308 Quad	26667
308RF	26667
TR505 & RF	26667
505	29333
485	32000
485RF	32000
TR605 & RF	32000
605	40000
608 Quad	53333

CAPACITY AND GVWR

The Gross Vehicle Weight Rating (GVWR) of the wagon is partially determined by its tire capacity. There are many tire options available from Horst, see the 'Payload and GVWR chart' at the back of this manual to determine the GVWR of your particular wagon and tire combination.

Each Horst wagon is designed to operate within these specifications. Operating the wagon above the specified GVWR capacity is a safety hazard, and will cause damage to the wagon and will void the warranty.

Operating the wagon above the 30 km\h (20 mile\h) speed may require a reduction in payload, and wagon brakes are recommended. (see the Payload and GVWR chart at the back of this manual)

Operating the wagon above the 30 km\h (20 mile\h) speed without payload reduction or wagon brakes is a safety hazard, and will cause damage to the wagon and will void the warranty.

Warning: BE AWARE of minimum tractor weight required to tow a full capacity unbraked load. Check the 'Minimum Tractor Weight Chart' for your wagon's minimum tractor weight.

Do not tow single or train loads more than 1.5 times the tractor weight. Ensure your towing vehicle has the weight capacity to tow and safely stop the loaded weight of the wagon or wagon train.

Unbraked towed loads that are too heavy for the tractor can cause loss of control when braking and may cause injury or death.

GVWR = (Gross Vehicle Weight Rating) is the curb weight + the payload. (subject to tire capacity rating)

Payload = is the maximum weight of the load allowed.

Curb Weight = is the total weight of the empty running gear ((tire + rim weight) x # hubs) + chassis weight + platform weight)

For detailed information see the Payload and GVWR chart at the back of this manual.

COMPONENTS AND FEATURES

The Horst Wagon series running gear wagons are designed for years of hard working service in a reliable, safe way. Its features make it the best choice for transporting from field to farm quickly and easily.

The owner or operator has the responsibility of being familiar with all the features of the Horst Wagon running gear wagons and know how to operate them. Each owner or operator must train all other operators before they start working with the machine.

Read this section carefully to learn how to use the running gear safely and how to set it to provide maximum field efficiency. By following instructions in conjunction with a good maintenance program, your Horst wagon will provide many years of trouble-free service.

Do not operate this wagon if you are not familiar with its features.

The 308RF is illustrated below, showing its basic components and features. Components and features are similar for all running gear wagon series unless noted. Review the various components and their position, the names of the components will be used to describe where they are and how they work through out the manual.

RUNNING GEAR WAGON SERIES COMPONENTS

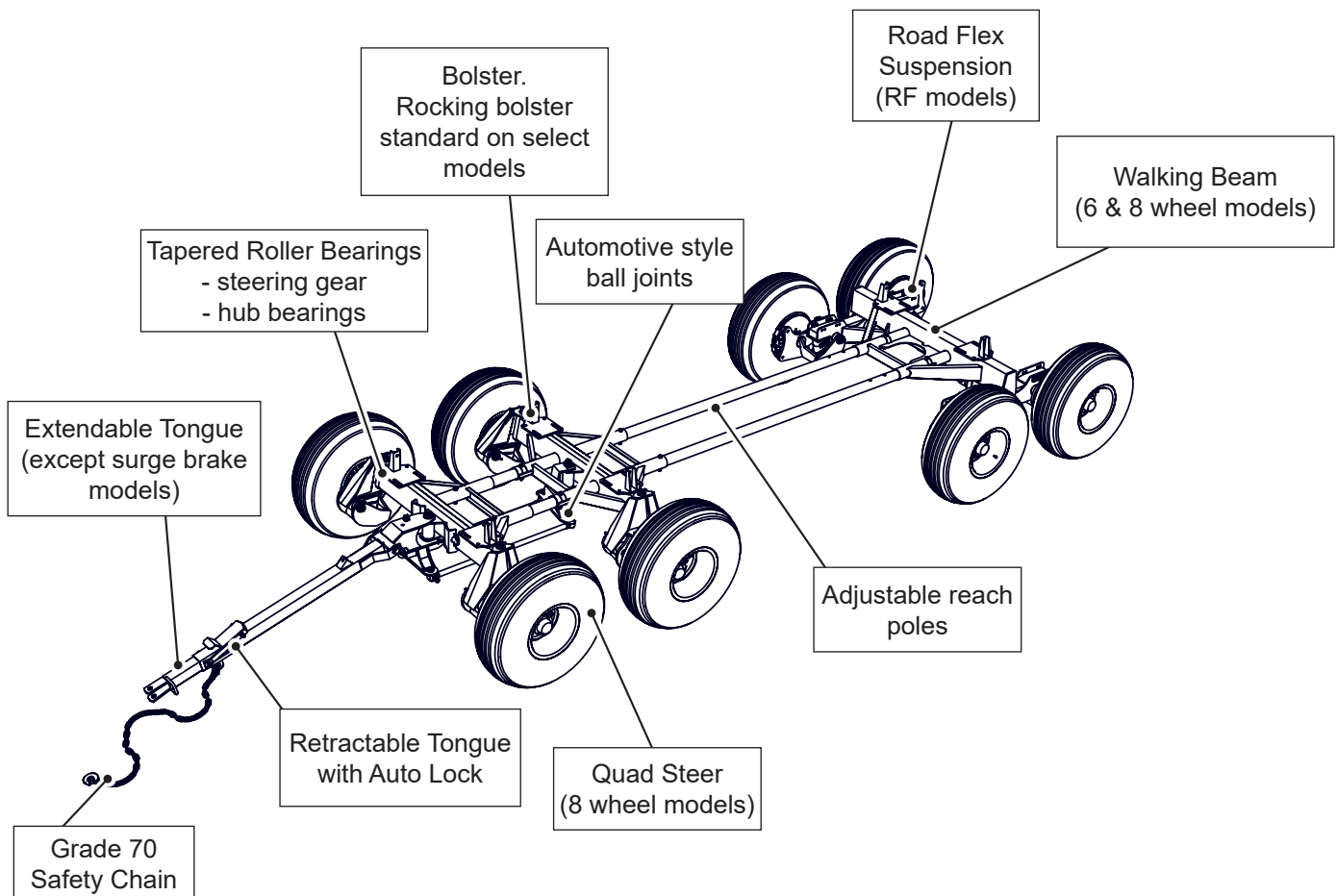

RUNNING GEAR TRAILER SERIES COMPONENTS

The Horst Wagon series running gear trailers are designed for years of hard working service in a reliable, safe way. Its features make it the best choice for transporting from field to farm quickly and easily.

The owner or operator has the responsibility of being familiar with all the features of the Horst Wagon running gear trailers and know how to operate them. Each owner or operator must train all other operators before they start working with the machine.

Read this section carefully to learn how to use the running gear safely and how to set it to provide maximum field efficiency. By following instructions in conjunction with a good maintenance program, your Horst trailer will provide many years of trouble-free service.

Do not operate this trailer if you are not familiar with its features.

The TR505RF is illustrated below, showing its basic components and features. Components and features are similar for the running gear trailer series unless noted. Review the various components and their position, the names of the components will be used to describe where they are and how they work through out the manual.

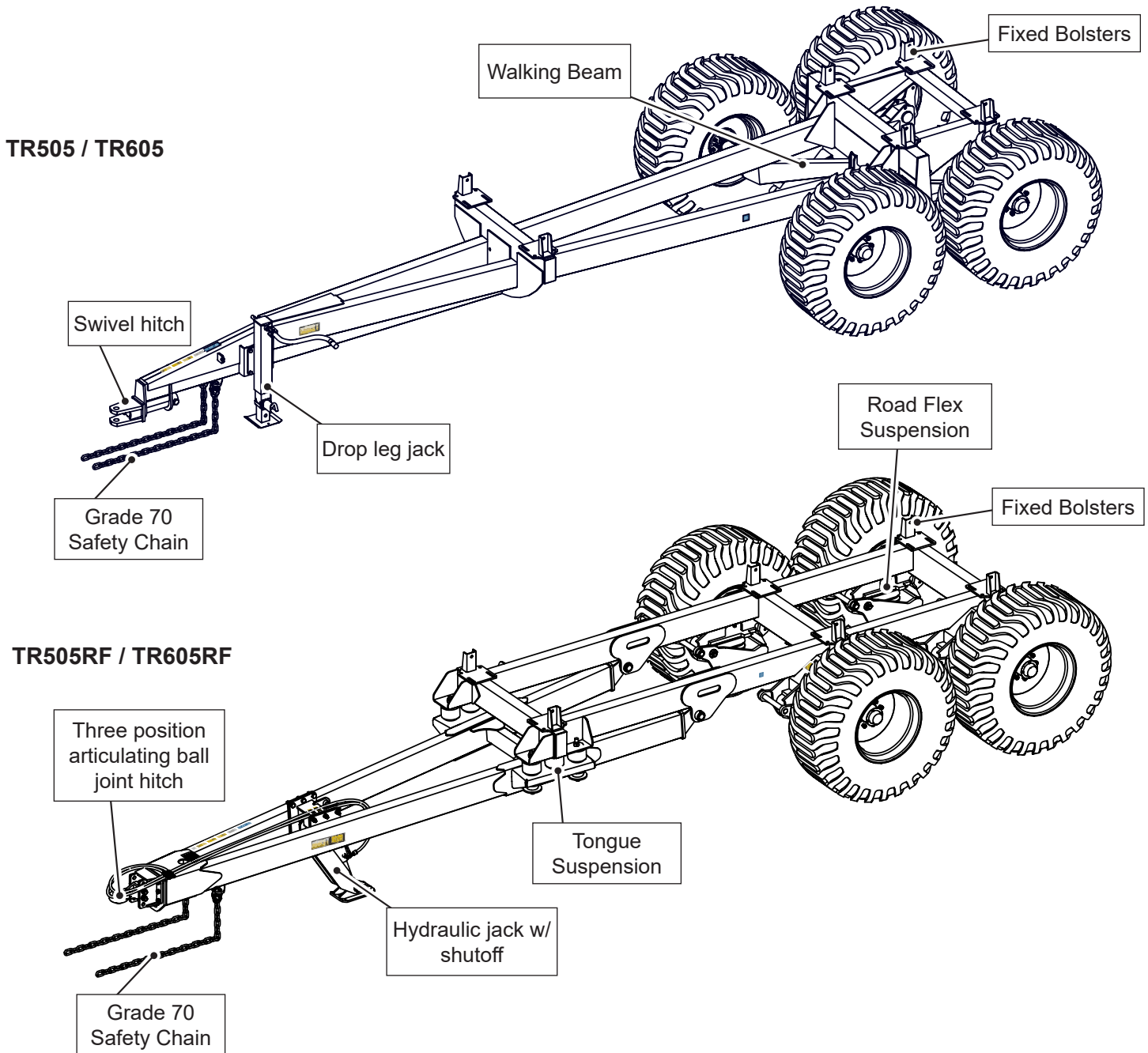

PRODUCT FEATURES

Not all features are available for all running gear.

SAFETY CHAIN:

1.5 meter (6ft) Grade 70 Safety Chain including clevis slip hook with safety latch

After attaching the clevis hitch use the safety chain assembly to secure your wagon to the tow vehicle

- Attach the tow hook to the hitch point on the tow vehicle, or wrap the chain around the hitch point and attach the hook to the chain.
- Ensure safety latch is closed on the hook.
- Store the chain by securing it around the tongue.

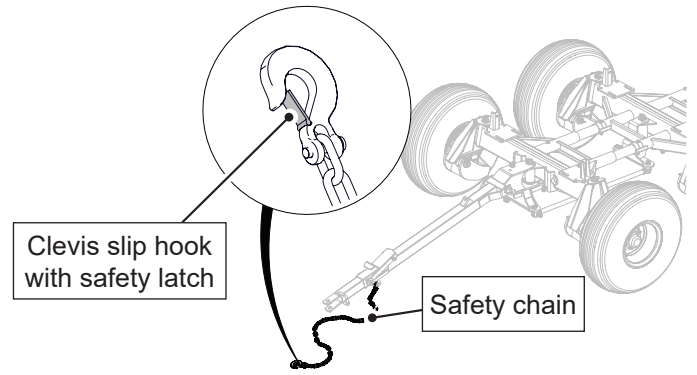

WARNING Machine Runaway Hazard

NEVER tow the running gear without a properly sized hitch pin retainer and a safety chain secured.

TONGUE EXTENSION WITH AUTO LOCK:

This feature will help eliminate the need for precise hook-up alignment. The extension provides some adjustment to aid in aligning the tongue to the hitch point. The extension auto-locks into position when pulling away.

- Back the tow vehicle close to the tongue.
- Pull up on the auto-lock latch, this releases the extension stop and will allow the extension to move inside the main tongue assembly.
- Move the extension as required to align the hitch to the tow vehicle hitch point,
- When aligned, secure the hitch with an appropriate sized hitch pin and secure with a lynch pin,
- Pull the tow vehicle ahead slightly to activate and engage the auto lock on the pullout.
- Stop the tow vehicle, check that the extension lock is in place and attach the safety chain.

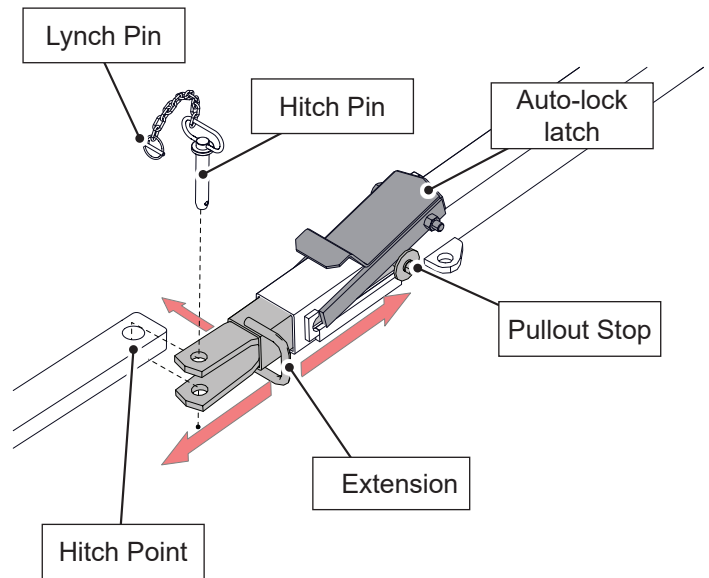

WARNING Pinch Point Hazard

When hitching or unhitching, be aware of pinch points at the hitch point, spring balancer and tongue pivot

EXTENDABLE TONGUE:

When extra length is required on the tongue, the extension may be extended. Length depends on wagon model. Not available on wagons equipped with surge brakes or trailers. Not available for optional pull-out tongue.

- Remove the extension stop hardware as shown in the diagram.
- Pull out the extension to the desired length, then replace the extension stop hardware.
- Ensure the hardware is fastened securely.
- The retractable, auto-lock feature will work in all extended positions.

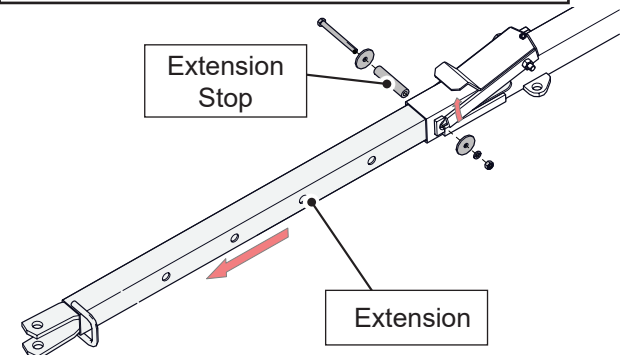

SWIVEL HITCH - TR505 / 605

The swivel hitch pivoting on its centre post thereby allowing the wagon to move freely over uneven terrain without causing stress to the hitching system.

- 1.5 " Hitch pin hole size.



WARNING **Pinch Point Hazard**

When hitching or unhitching, be aware of pinch points at the hitch point, and tongue pivot

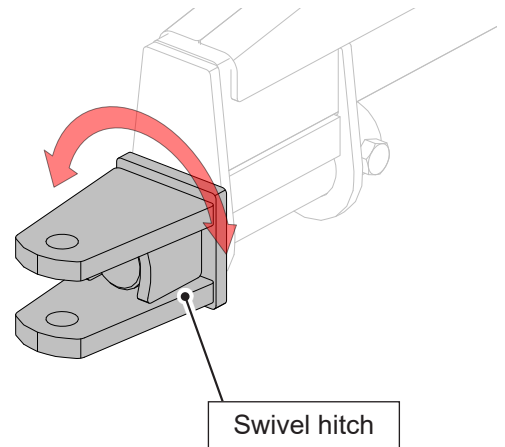

ARTICULATING HITCH - TR505RF / 605RF

The articulating hitch features a ball joint that allows for pivoting up to 45° in any direction thereby allowing the wagon to move freely over uneven terrain without causing stress to the hitching system.

- 2.0" Hitch pin hole size.
- Three position mounting
- Replaceable ball joint

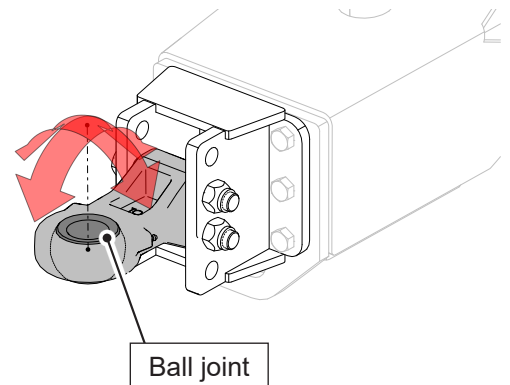

DROP LEG JACK - TR505 / 605

The drop leg jack is a side crank, with a 12.5" stroke

- 13.5" additional drop leg stroke
- Spring loaded drop leg return with lock pin
- 12,000 lb support capacity
- 10,000 lb lift capacity

Extending

- Disengage drop leg pull pin by rotating to the disengaged position.
- Carefully move the drop leg to the desired position using your foot.
- Engage the drop leg pin by rotating it to the engaged position and into the desired adjustment hole.
- Verify that the drop leg pin is fully inserted into the jack
- you may have to adjust the drop leg to fully seat the pin into the hole location.

If you are unable to fully seat the pin **DO NOT USE**.

- Use the crank to make final adjustments.

Retracting:

WARNING: Spring loaded drop leg will naturally retract very quickly.

- Verify that the jack is not supporting any load.
- Place your foot on foot plate to control the return of the drop leg.
- Disengage drop leg pin by rotating to the disengaged position.
- Carefully allow the drop leg to retract.
- Engage the drop leg pin by rotating it to the engaged position, use the crank to make final adjustments.

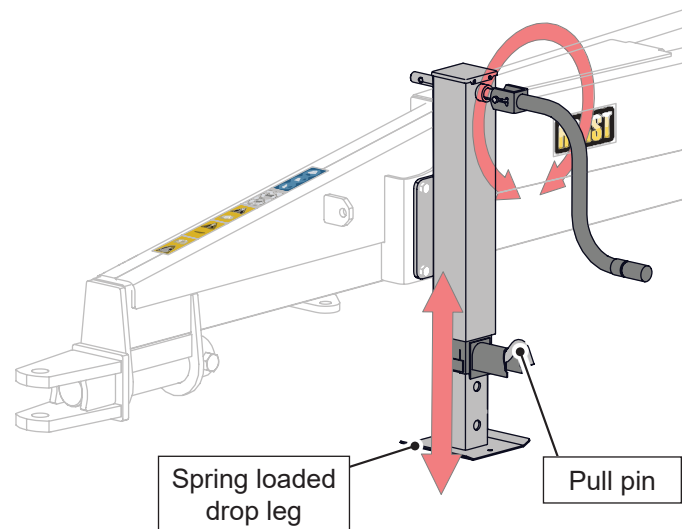

WARNING **Pinch Point Hazard**

When using the drop leg jack, be aware of pinch points at the pull pin and drop leg.

HYDRAULIC JACK - TR505RF / 605RF

The jack is hydraulic controlled by the tractor remotes

- 8" x 3" hydraulic cylinder
- Shut off valve for easy decoupling
- 2 x12' hydraulic hoses with pioneer couplers

Extending or retracting

- Ensure the shut off valve is in open position.
- Make the hydraulic connection at the tractor remotes
- Extend or retract the jack by activating the tractor remote.

When uncoupling the hydraulic hose, turn the valve to off position. This will keep the jack pressurized when relieving the pressure on the hydraulic hose to disconnect the couplers.

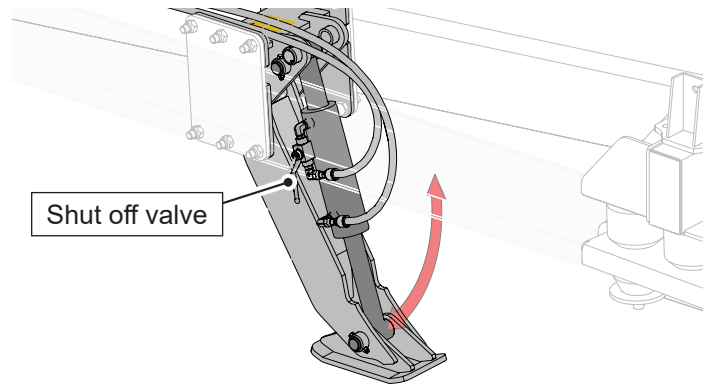

WARNING

Pinch Point Hazard

When using the hydraulic jack, be aware of pinch points at the jack leg.

BOLSTERS

Select models feature adjustable width bolster stakes. Up to three positions depending on your wagon model.

Bolster stakes are easily adjustable by removing the nuts and bolts moving the bolster to the new position and reassembling the nuts and bolts.

Rocking bolsters are standard on all non suspension square tube wagon models and are fixed width.

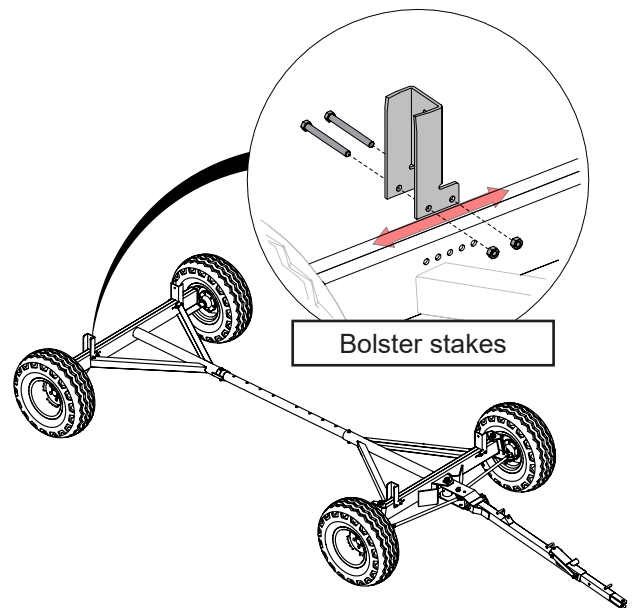

ROCKING BOLSTER:

Rocking bolsters are standard on square tube non Road Flex wagons, on Digi Star equipped wagons and optional on select round tube wagons.

The heavy duty rocking bolsters let you solidly attach a load from gravity bins to hay racks.

The Rocking Bolster design allows heavy loads a degree of flex and movement reducing stress on the running gear frame and providing more control over uneven terrain.

No adjustments are required, and needs only periodic maintenance for the pivot bearings. (see maintenance section)

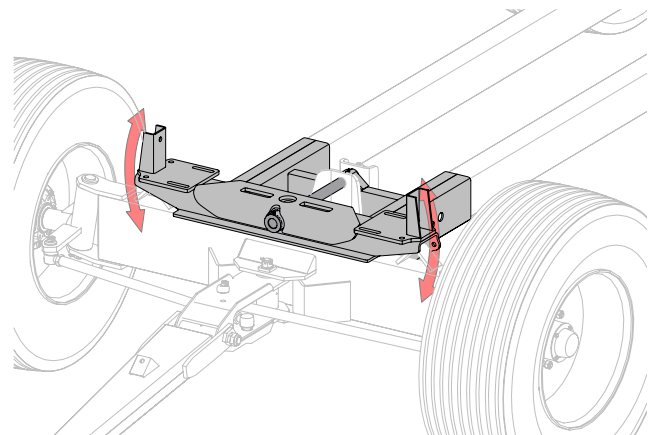

CAUTION

Operational Hazard

Personal Protection Equipment (PPE) is required while working in and around this machine.



WARNING

Pinch Point Hazard

Be aware of pinch points around the rocking bolster

ADJUSTABLE REACH POLES

The wagon running gear models feature adjustable reach poles to fine tune wheel base requirements

Wheel base adjustment should be made at the assembly stage, see the assembly manual included with your running gear.

Round Reach Poles

- Poles are optionally available in a variety of lengths and have up to 5 adjustment positions depending on the length of the poles the wagon has.
- All round reach poles feature locking rings to allow for wagon flex, while ensuring a secure connection.

Note: model 185F four wheel steer is not adjustable.



CAUTION

Heavy or bulky parts

Prevent potential strain injury, use approved lifting equipment or ask for help when lifting or moving heavy, bulky parts.

Square Reach Poles

- Reach poles are available in a variety of lengths and have up to 6 adjustment positions.
- Adjustment is made at the axle pole receivers at each axle.

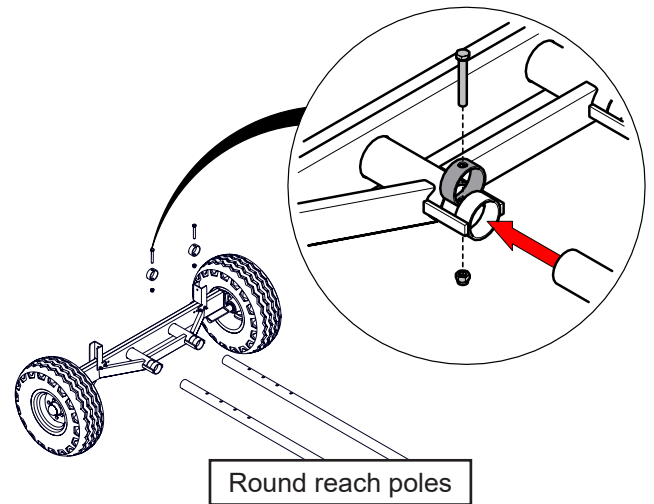

Round reach poles

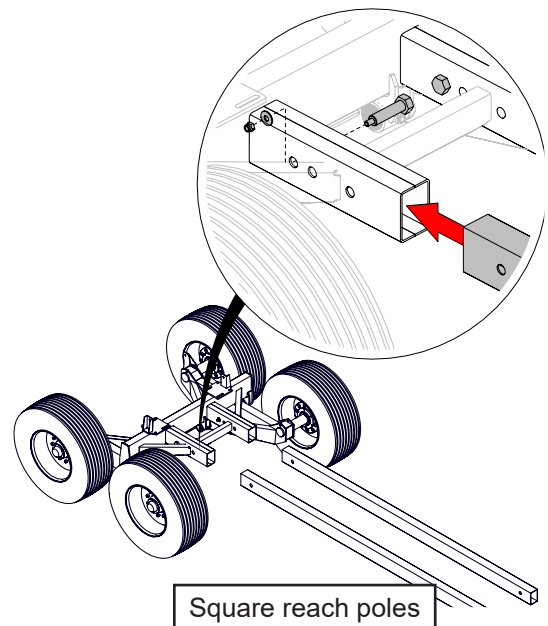

Square reach poles

ROAD FLEX INDEPENDENT SUSPENSION:

The RF series wagons feature Road Flex independent suspension system. This patented innovation smooths out bumps, as the wagon is pulled down the road or across the field..

At the core of Road Flex suspension are shock absorbing rubber blocks. These specially designed blocks are housed in a heavy duty steel case, pivoting on a steel pin supported by taper roller bearings.

No adjustments are required, and needs only periodic maintenance for the taper bearings. (see maintenance section)

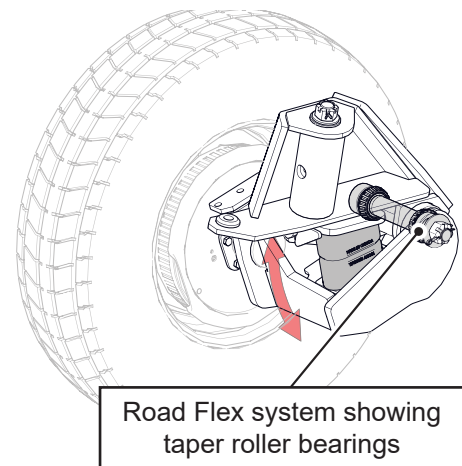

Road Flex system showing taper roller bearings

FOUR WHEEL STEER

The 185F wagon features four wheel steer. This makes the wagon very manoeuvrable, and able to get into a narrow field entrance more easily. The wagon tracks right behind the tow vehicle, eliminating having to make wide turns to avoid cutting corners.

As the front wheels turn to follow the tongue the rear wheels turn in the opposite direction, the result is that the rear end tracks right along with the front wheels.

Backing a four wheel steer wagon may require some practice to master! The concept is similar to backing a two wheel steer but two points to bear in mind:

- As soon as you begin to turn the wagon, the back end will immediately begin turning.
- The rear wheels always turn in the direction of the tongue: if the tongue goes to the right the rear of the wagon goes to the right.

The result is that you may find that you'll tend to over steer at first. Practice is the best solution.

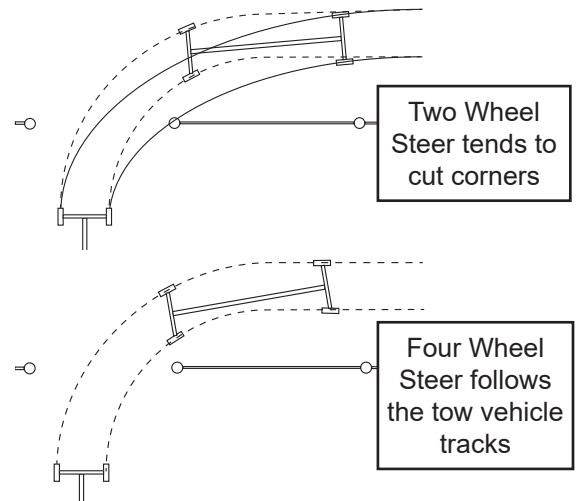

WARNING **Operational Hazard**

Be aware of potential collision when parked directly beside a building or object: starting off on an angle, the back end of the trailer will begin turning as soon as you pull away, causing a collision.

To avoid collision, start off straight then begin your turn. Proceed slowly to ensure that the wagon will clear buildings or objects as you pull away.

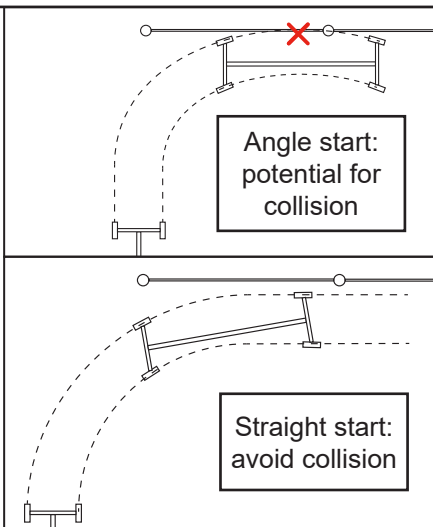

OPTIONAL FEATURES

This section applies to running gear that have been ordered with factory installed options:

BRAKES

Selected running gear are available with optional hydraulic surge brakes or hydraulic disc brakes on two or four wheels depending on the model and option selected. Brakes options include installation on two or four wheels depending on the wagon model and option selected.

HYDRAULIC SURGE BRAKES

Hydraulic surge brakes come equipped with surge brake tongue which contains the actuating mechanism for the surge brakes and the hydraulic fluid reservoir. When moving forward, as you brake the tow vehicle the weight of the wagon surges forward which applies pressure on the actuating mechanism, which then applies the brakes.

Horst Wagon surge brakes are free backing, meaning the brakes have a unique design that moves the front brake shoe away from the drum when backing. This allows the trailer to roll free when backing up. Be aware that while backing, the brakes have no braking power, so your tow vehicle's brakes carry the entire load during the backing process.

Each 13" brake is fitted with two 2 1/2" wide non asbestos brake linings and are not self adjusting. Brake system should be inspected and brakes adjusted after the first 320 km (200 miles) of operation when the brake shoes and drums have "seated". After initial adjustment brakes and brake system should be inspected and adjusted on a yearly basis or more frequently during heavy use.

Brake fluid level should be checked at each use.

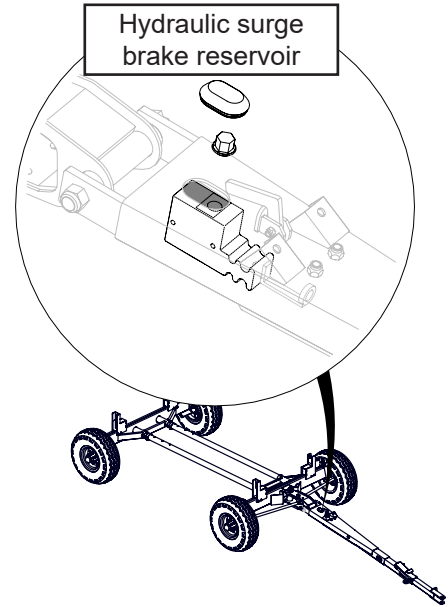

HYDRAULIC DISC BRAKES

Horst Wagon hydraulic disc brakes are engineered to be used with tractor brake port and come equipped with high pressure 3000 psi brake callipers designed to be used with hydraulic fluid.

Connection is made at the tractors brake port with included ISO 5676 flat face coupler designed to connect the braking system of running gear to the brake ports of agricultural machines, which conforms to ANSI S648 Agricultural Field Equipment Braking standard.

When parking or transporting and the brake system is not coupled to the tractor, connect the hose end coupler to the coupler holder to avoid pressure buildup and brake failure.

⚠ WARNING
Operational Hazard
Horst brake systems are designed for assisting in stopping and are not to be relied on as the only means for stopping the tractor & running gear.

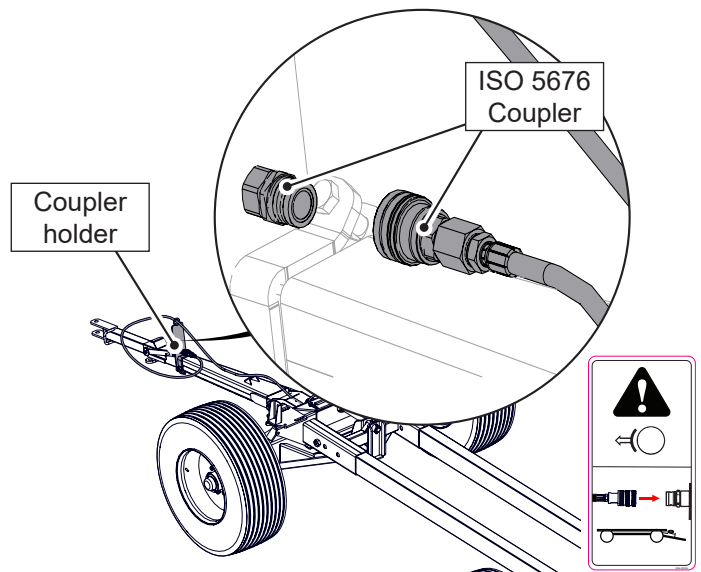

SPRING BALANCER:

Spring balancer option is available in single or double spring configuration.

Springs offset and balance the weight of the tongue making it easier to hook up.

- Tension may be adjusted by tightening up the nuts at the end of the eye bolts. (see illustration)
- For dual spring balancers ensure that both nuts are tightened the same amount.

Note: surge brake models have dual spring balancers as standard equipment.

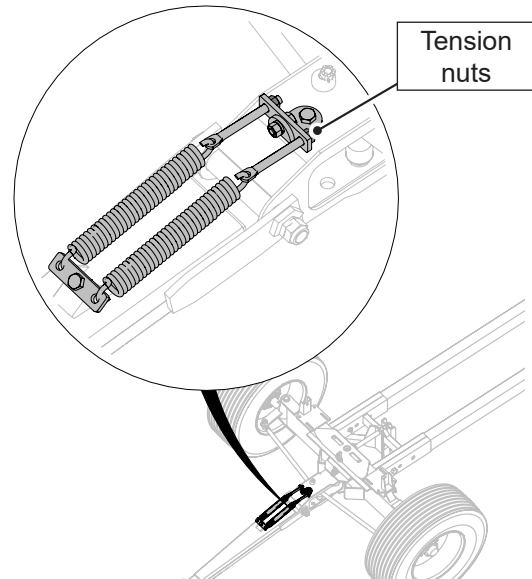

DIGI-STAR SCALE SYSTEM:

Four load sensing cells ensure fast and accurate load measurement viewable thru the LCD read out control panel.

After your equipment platform of choice is installed on the wagon, mounting the control panel may done on the platform or inside the cab.

Digi Star scale system comes equipped standard with rocking bolsters.



Digi-Star control console

TONGUE PULL-OUT WITH AUTO LOCK:

This feature will help eliminate the need for precise hook-up alignment. The pullout provides up to 12" adjustment to aid in aligning the tongue to the hitch point.

The pull out tongue also features three fixed position extensions, allowing for up to 18" of extra tongue length.

The auto lock feature is activated after hook up by backing up the wagon to engage the lock.

- Back the tow vehicle close to the tongue.
- Pull up on the spring loaded auto-lock latch, this releases the pullout and will allow the pullout to move inside the main tongue assembly.
- Move the pullout as required to align the hitch to the tow vehicle hitch point,
- When aligned, secure the hitch with a appropriate sized hitch pin and secure with a lynch pin,
- Back the tow vehicle engage the auto lock latch on the pullout.
- Stop the tow vehicle, check that the pullout lock is in place and attach the safety chain.

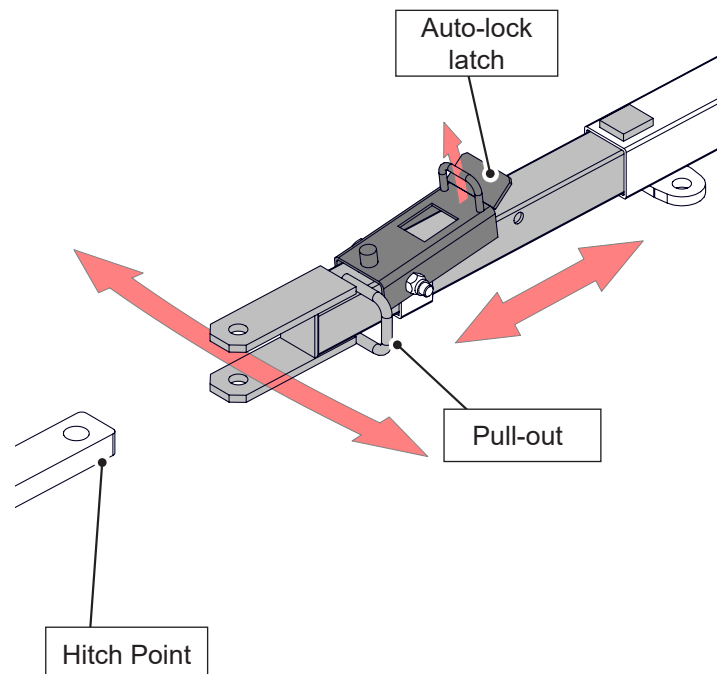

TONGUE PULL-OUT EXTENSION:

The pullout tongue features three fixed position extensions, allowing for up to 18" of extra tongue length. The tongue length can be extended in 9.0" increments.

- Pull up on the auto-lock latch, and move the pullout slightly.
- Remove the pullout stop nut and bolt on the tongue.
- Remove the nut and bolt from the auto lock latch.
- Carefully remove the latch and be aware of the tension spring under the latch.
- Slide the latch collar to the new position
- Assemble the auto lock latch and tension spring onto the collar with the nut and bolt.
- Assemble the pullout stop bolt and nut in the corresponding position on the tongue.
- Test that the auto lock functions correctly after making the position change.

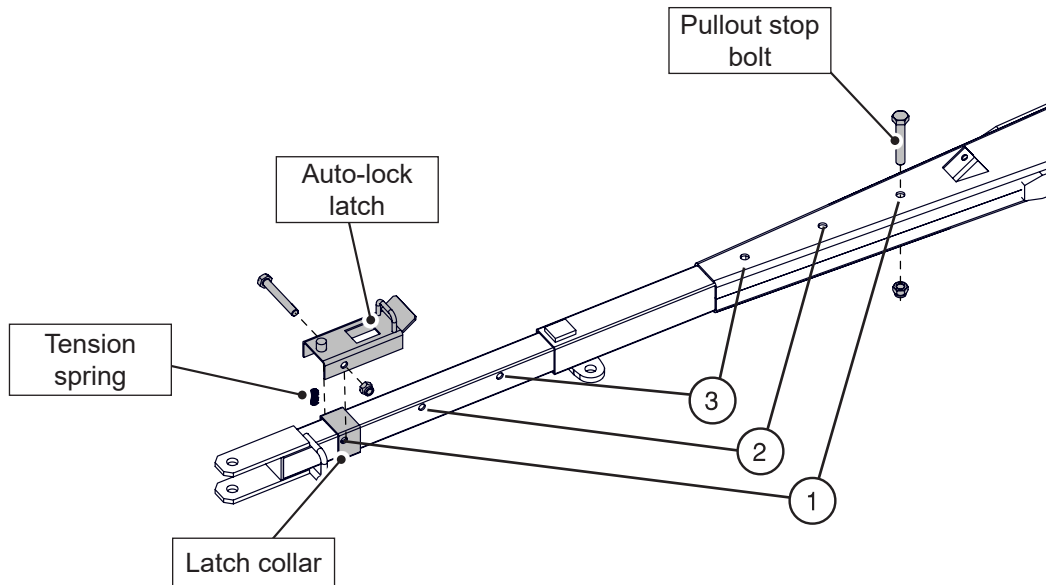

INITIAL SETUP

Before attempting to use, ensure the running gear is either attached to the tow vehicle or the wheels have been secured with wheel chocks to prevent unwanted movement during the loading process.

INSTALLING MATERIAL HANDLING PLATFORM

INSTALLING THE PLATFORM

Material handling equipment platform (gravity bins, hay racks etc) should be attached to the running gear by the bolster stakes located on the running gear axles or frame.

Follow the fastening recommendations of the platform manufacturer if available.

If no instructions are available from the platform manufacturer, Horst recommends using the following means of attachment to ensure a secure platform attachment with optimum flexibility.

- **Wagons without rocking bolsters:**
 - If your wagon features adjustable bolsters, then make the width adjustment as required.
 - At the rear section bolt the material handling equipment to the rear bolsters, ensure the fastening hardware is at least a grade 8, and sufficient size to withstand the stresses and torque to safely hold the platform to the running gear.
 - At the front use a chain at each bolster and chain the front sill of the platform to the front axle (**do not bolt**), allowing some slack for flexing and movement. Ensure the chain is at least grade 70, and correct size to safely hold the loaded platform to the running gear.
- **Wagons with rocking bolsters and trailers:**
 - If your wagon features adjustable bolsters, then make the width adjustment as required.
 - At the rear sections bolt the material handling equipment to the bolsters,
 - At the front sections bolt the material handling equipment to the rocking bolsters,
 - Ensure all the fastening hardware at least a grade 8, and sufficient size to withstand the stresses and torque to safely hold the loaded platform to the wagon or trailer.

WARNING
Operational Hazard
Restricting slack by bolting all four corners of the platform to the wagon without rocking bolsters may result in damage to the wagon and may result in death or injury

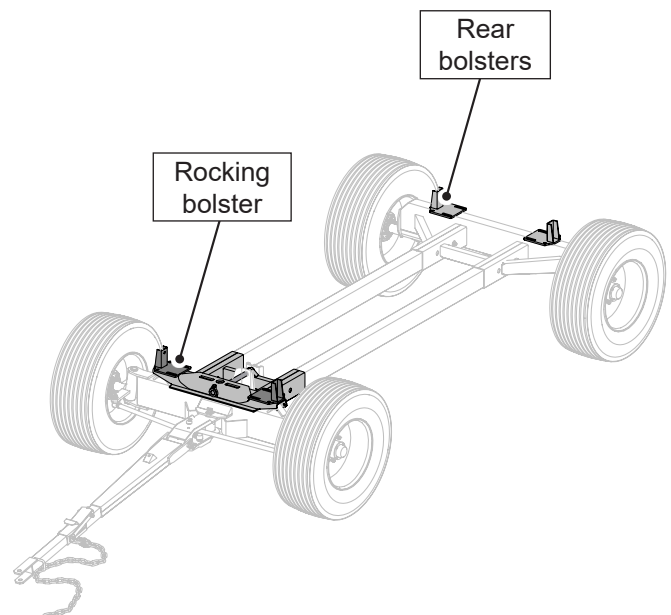

DETERMINE SAFE PAYLOAD

Refer to the '**Payload and GVWR Chart**' at the back of this manual for payload reference information.

When installing material handling platform on the running gear (gravity bins, hay racks etc) ensure the running gear has the GVWR required to handle the payload:

- Determine the payload of the running gear: subtract the weight of the material handling platform from the payload of the running gear (see '**Payload and GVWR Chart**' at the back of this manual)
- Platform + Payload + Curb Weight should never exceed the Gross Vehicle Weight Rating (GVWR) of the wagon.

INSTALLING DIGI STAR CONTROL CONSOLE

Caution: only qualified personnel should make modifications and connections to the power units electrical system.

If your wagon includes the optional Digi Star scale system, then follow these final steps to mount and connect the control console.

After installation of your equipment platform of choice determine console location. Console installation may be done on the equipment platform or inside the cab. Extension cabling is included with the system

- The console comes with a mounting bracket and two sets of nuts and screws.
- Mounting surface for the bracket should be on a secure flat surface safe from potential damage.
- Mount the bracket using the hardware included
- The console mounts on the bracket flange by the rail on the back of the console.
- Determine the power source for the console and use the fused panel lead to make the connection to the power source.
- Do not connect the power cable to the console, follow the directions in the EZ2500 operators manual for connecting the remaining cables.
- Once all remaining cables are connected, connect the power cable to the console.
- Follow directions in the EZ2500 operators manual for setup and operation instructions.

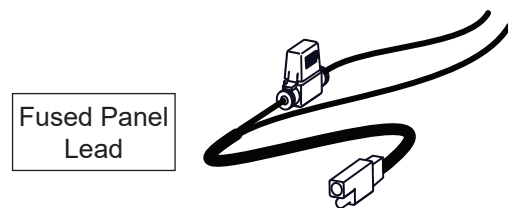
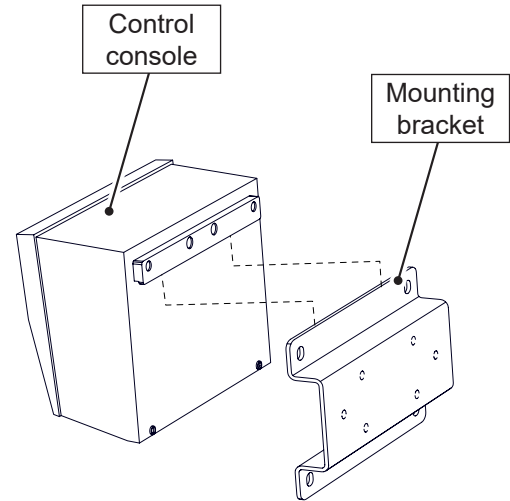

ARTICULATING HITCH ADJUSTMENT

Models TR505RF and TR605RF include the articulating adjustable hitch. The Hitch features a choice of three positions.

- Ensure the wheels have been secured with wheel chocks to prevent unwanted movement.
- Determine which position you require.
- Remove the two bolts and nuts holding the hitch.
- Move the hitch to the new position.
- Bolt the hitch in place.
- Torque as required by the torque chart at the back of this manual.

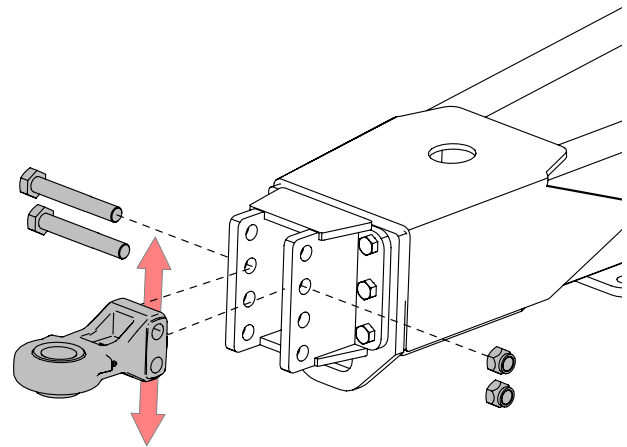

FIELD OPERATION

This section describes how to safely and effectively operate the Horst wagon or trailer wagon in the field of operation. By following recommended procedures, a safe working environment is provided for the operator, bystanders and the area around the work site. Not all situations and conditions can be addressed, proceed with care & caution and use safety as your guide.

The owner or operator has the responsibility of being familiar with the operation of the wagon or trailer and must train all other operators before they start working with the machine.

Work in a safe manner and follow all instructions exactly, safety is everyone's business. Untrained operators are not qualified to use the machine.

OPERATION SAFETY CHECKLIST

- ✓ NEVER allow helpers or bystanders under or near while loading the implement.
- ✓ Make sure that the load is fastened securely to the implement before moving.
- ✓ Inspect all fastening devices, do not use if worn or damaged.
- ✓ Check that coupler is secured with a hitch pin. Secure the wagon with the safety chain.
- ✓ Ensure your towing equipment is rated to tow the GVWR weight of the implement.
- ✓ Do not permit riders while transporting this implement, with or without a load.
- ✓ Make sure that everyone is clear before moving the implement. NEVER position yourself between the towing unit and the implement.
- ✓ Where possible, avoid operating near ditches, embankments and holes.
- ✓ Loading or unloading an unhitched implement, be sure to properly block or chock the wheels to prevent the implement from moving.
- ✓ Inspect rims for dents or damage, check wheel lugs and tighten if required.
- ✓ Check brakes, lighting indicators are operational if applicable.

PREPARE

- Clear the area of bystanders, especially small children.
- Training: each operator must be trained and familiar with the set up and operation of the product and its components.
- It is dangerous and unlawful to tow with an under rated tow vehicle on a public road.
- Review:
 - Components and Features
 - Operation Safety Checklist
- Survey the work site, a flat area will make loading & unloading easier and safer, remove debris and make note of nearby or overhead obstructions.
- It is recommended that each person wear appropriate Personal Protective Equipment (PPE) whenever working in the vicinity. This equipment is designed to prevent injury to any personnel in the area. This list includes but is not limited to:
 - Safety shoes with slip resistant soles.
 - Safety glasses.
 - Hearing protection.
 - Heavy or leather gloves
- Before use, inspect the implement (see service & maintenance section) and check the following:
 - Wheel alignment
 - Tire pressure
 - Check wheel lug nuts and ensure they are all properly secured
 - Check all chains, nuts, bolts and screws and ensure they are all properly secured
 - If traveling on a public road ensure an SMV sign is attached to the rear of the wagon.
 - In the USA traveling on a public road faster than 30 km/h (20 MPH) requires an SIS sign.
 - Note: see the 'Payload and GVWR Chart' to determine load limits of your running gear.

LOADING THE WAGON

Before attempting to load the header wagon, ensure the wagon is either attached to the tow vehicle or the wheels have been secured with wheel chocks to prevent unwanted movement and potential injury during the loading process.

Loading will depend in the equipment platform that has been installed on your wagon. Consult the owners manual of the equipment platform manufacturer for safe loading procedures.

Review your power units operation instructions to ensure safe and proper procedures are followed.

TOWING

Be aware of local, provincial, state, and national codes concerning towing implements on public roads. If towing at or below 30 km/h (20 Mile/h) a SMV (slow moving vehicle) sign must be attached to the rear of the implement.

In the U.S. tractors towing greater than 30 km/h (20 mile/h) but under 50 km/h (30 mile/h), require an SIS sign in addition to an SMV.

When towing on public roadways ensure the tow vehicle and all its towing components are rated to tow and stop the gross vehicle weight rating (GVWR) of the implement. Check that brakes and lighting on the wagon are functioning properly (if equipped).

When transporting at night, It is recommended to turn on your running lights.

Plan your route, if possible avoid busy highways, be a safe and courteous driver, and obey the rules of the road.

BEFORE TOWING:

- Review **Transport Safety** section.
- Check all pull pins are in place and secured.
- Ensure the load is attached securely to the wagon.

WARNING
Wagon Runaway Hazard
NEVER tow the wagon on a public road without a coupler lock pin and the safety chain secured.



ATTACH THE RUNNING GEAR

- Wagon Auto-lock Latch:
 - Back the tow vehicle close to the tongue, and set the parking brake.
 - Carefully pull up on the auto-lock latch, move the tongue in/out as required to align the clevis to the tow vehicle hitch point,
 - Connect the clevis with a grade 5 hitch pin sized for your wagon gross vehicle weight rating and secure with a lynch pin.
 - Engage the auto-lock latch. (pull ahead for standard extension style tongue or back up for optional pull-out style tongue) Ensure the auto-lock is securely engaged.
- Trailer:
 - Back the tow vehicle and line up the draw-bar to the hitch and set the parking brake.
 - Secure the hitch with a grade 5 hitch pin sized for your trailers gross vehicle weight rating and secure with a lynch pin.
- Attach the safety chain:
 - Ensure the chain is through the chain support.
 - Secure chain on the tow vehicle at the towing attach point.
 - Do Not allow more slack than necessary for turning.
 - Do not allow the chain to drag, wrap the excess chain around the hitch point.
 - Attach the tow hook to the hitch point on the tow vehicle, and attach the hook to the chain.
 - Ensure safety latch is closed on the hook.
- Recheck all connections and you are ready to tow.
 - Auto-lock latch
 - Tow pin
 - Safety chain
 - Trailer models - retract jack stand

WARNING
Runaway Hazard
Replace the safety chain if one or more links or end fittings are broken, stretched or otherwise damaged or deformed.

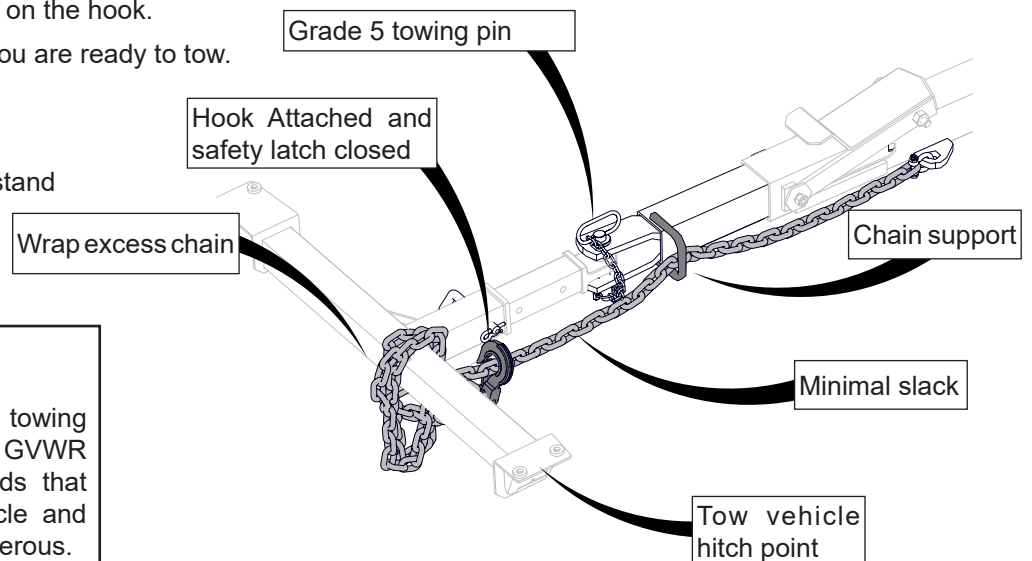

CAUTION
Operational Hazard

Ensure the tow vehicle and its towing components are rated to tow the GVWR of the running gear. Towed loads that are too heavy for the tow vehicle and components is unlawful and dangerous.

HYDRAULIC DISC BRAKES

For models with the optional feature of 2 or 4 wheel disc brake system.

The disc brakes on your wagon are designed to be activated with the tractors dedicated rear line hydraulic brake port.

Make the hydraulic brake connection with the hydraulic brake hose located on the wagon / trailer tongue, to the brake port on the tractor.

Test your brakes before proceeding.

For connecting braked wagons in a train configuration, a hydraulic coupler is included on the rear wagon axle. This allows for braking on all wagons using the same brake system. Not available on the TR505 and TR605 series.

Note: All brake system couplers are ISO 5676 flat face couplers designed to connect the braking system of Horst running gear to the brake ports of agricultural machines.

WARNING Operational Hazard

Ensure brake hose couplers are clean and free of dirt before coupling to brake ports. Contaminated fluid in the brake system will cause brake failure.

HYDRAULIC BRAKE COUPLER HOLDER

When parking or transporting and the brake system is not coupled to the tractor, connect the brake line hose end to the coupler holder to avoid pressure buildup and unwanted brake activation.

See illustrations below for coupler holder locations

Coupler holder

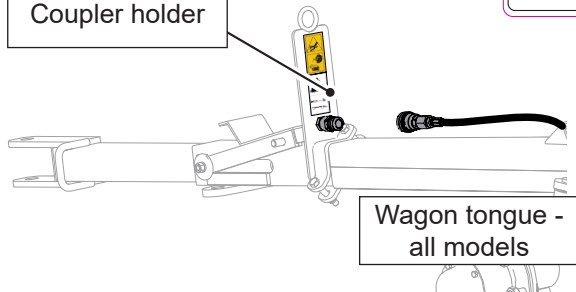

Wagon tongue -
all models

Coupler holder

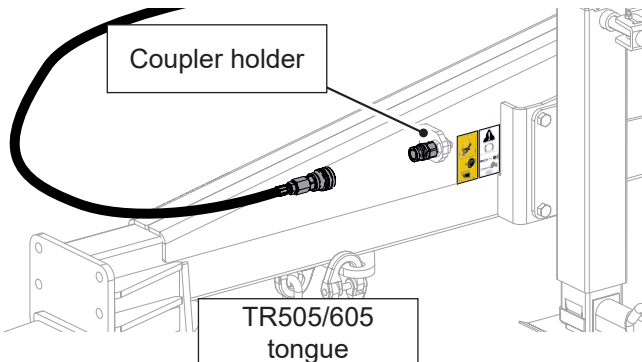

TR505/605
tongue

Brake system
hydraulic coupler

Coupler holder

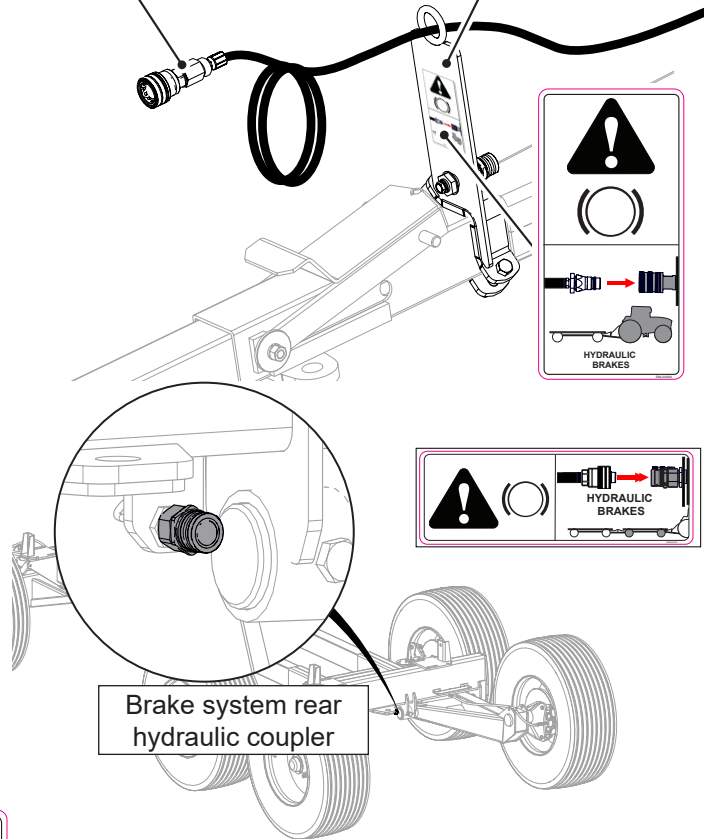

Brake system rear
hydraulic coupler

WARNING Operational Hazard

Brakes are designed for assisting in stopping and are not to be relied on as the only means for stopping the running gear.

CAUTION Operational Hazard

Aggressive braking which results in wheel lock up and sliding, can cause a dangerous loss of control and result in personal injury or death.

Coupler holder

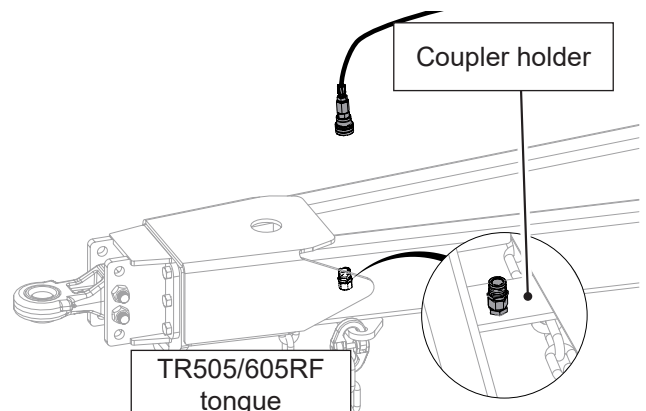

TR505/605RF
tongue

WAGON TRAINS

Select wagon models feature a rear hitch for towing in a wagon train configuration.

Wagon trains must be limited to a maximum of two wagons when fully loaded with a suitable capacity tractor. Towing more than two fully loaded wagons is dangerous and could result in death or serious injury and or implement damage.

When traveling at 30 km/h (20 mile/h) do not tow train loads more than 1.5 times the tractor weight . Ensure your towing vehicle has the weight capacity to tow and safely stop the loaded weight of the wagon train.

Operating the wagon above the 30 km\h (20 mile\h) speed may require a reduction in payload, and wagon brakes are recommended. (see the 'Payload and GVWR Chart' at the back of this manual)

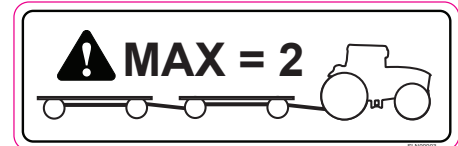
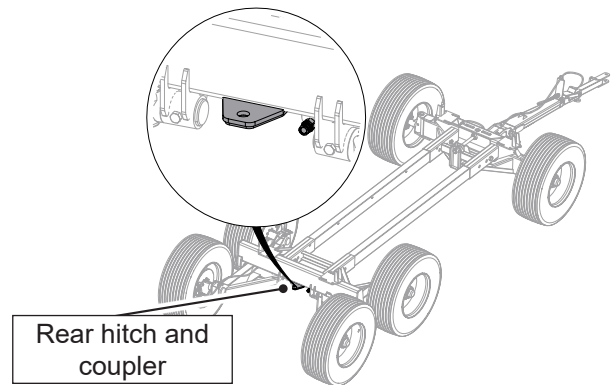

STORAGE

STORAGE SAFETY CHECKLIST

- ✓ Store the implement away from work area's and livestock.
- ✓ Do not permit children to play on or around the stored machinery.
- ✓ Ensure all pins, latches and locks are secure.
- ✓ Block or chock the wheels to prevent unexpected movement
- ✓ Guard any sharp corners
- ✓ TR505 / 605 series: extend jack stand

After the season's use or when the machine will not be used for a period of time, completely inspect all parts of the implement. Replace or repair any worn or damaged components to prevent any unnecessary down time at the beginning of the next season. Your implement is an important investment. Spending some time to protect it from rust and corrosion will result a safer, longer service life and better performance..

PLACING IN STORAGE:

1. Thoroughly wash the machine with a pressure washer or water hose to remove all dirt, mud or debris.
2. **Hubs: Do not pressure wash the seal lip area** - water seeping into the bearing may cause premature wear and damage.
3. Remove all remaining material and debris from the machine.
4. Inspect for damaged or worn parts. Repair or replace before next season.
5. Replace any missing or unreadable safety decals.
6. Repaint any chipped or scraped areas to prevent rust and corrosion.
7. It is best to store the machine inside in a dry clean area. If that is not possible, cover with a waterproof tarpaulin and tie down securely.
8. If your wagon / trailer is equipped with hydraulic disc brakes ensure the brake line hose coupler is attached to the coupler holder, to avoid damage to the brake circuit from pressure buildup.

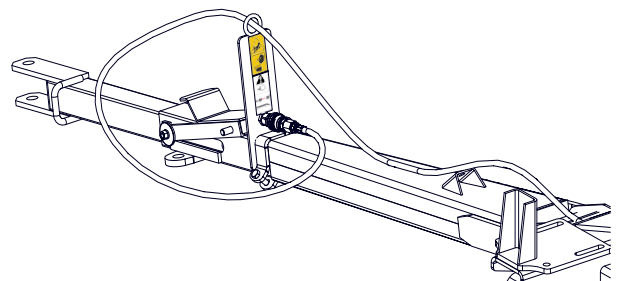
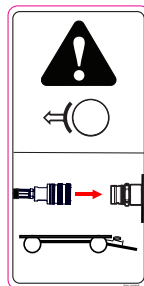

SERVICE & MAINTENANCE

Good maintenance is your responsibility. Poor maintenance is an invitation to trouble. Maintenance is a good preventative in avoiding mechanical failure of any kind or catastrophic failure.

To keep your implement in good working condition, and increase bearing life as well as maintain ease of operation, periodic lubrication is essential. This also helps to flush out moisture and dirt.

By following a careful service and maintenance program for your machine, you will enjoy many years of trouble-free operation.

Replacement of parts should be done by a qualified personnel only. Keep a record of all maintenance, to ensure scheduled inspections and maintenance are performed.

MAINTENANCE SAFETY CHECKLIST

- ✓ Follow good shop practices.
- ✓ Keep service area clean and dry.
- ✓ Use adequate light for the job at hand.
- ✓ Never work under equipment unless it is blocked securely
- ✓ Parts replacement should be performed by qualified personnel to ensure safe and complete installation.
- ✓ A fire extinguisher and first aid kit should be kept readily accessible.
- ✓ Always use personal protection devices such as eye, hand, foot and hearing protectors.
- ✓ Use heavy gloves when handling heavy or sharp components.
- ✓ Ensure wagon is disconnected from the towing vehicle and wheels are chocked.

WHEEL HUBS:

INSPECT HUBS MONTHLY.

Lift the empty trailer off the ground and support with adequate jack stands.

On each wheel assembly:

- Push back and forth look for unusual front to back movement or chatter.
- Check the wheel is free spinning with no grinding noise.

If any issues are found repack of the bearings is recommended.

HUB COMPONENTS

Wheel bearings, seals and cups should, cleaned, inspected, re-packed & adjusted:

- Anytime issues are detected on inspection
- Every 500 hours of operation with year round use.
- Every 1000 hours of operation with seasonal use
- Annually at minimum.

REPACKING

Repacking should be performed by qualified personnel.

Use a premium quality, multipurpose, extreme- pressure (EP2) calcium sulfonate or equivalent grease for the bearings (NLGI GC-LB Certified)

- Disassemble hub and remove all old grease.
- Clean and inspect the bearing seal for wear or damage, replace if required
- Clean and inspect the bearings for wear or damage, replace if required.
- Clean and inspect the bearing cups for wear or damage, replace if required.

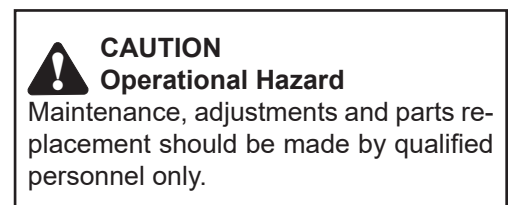
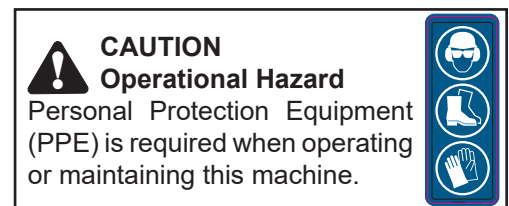

WHEEL BEARING PRELOAD

After inspection or repacking setting the preload correctly is essential. Adjustments should be performed by qualified personnel.

- Install the washer and nut.
- Tighten the nut with the wrench until you can barely turn the hub by hand. This will seat the bearings.
- Back the nut off until it is loose, approximately ½ turn.
- Retighten the nut to the correct cotter pin hole (you should be able to rotate the hub with one hand). This will give the pre-load on the bearings.
- Install the cotter pin.(new cotter pin is recommended)
- Put 2 – 3 beads of grease around the inside diameter of the dust cap, not in the center or end of the dust cap. The dust cap should be approximately 1/3 full.
- Install dust cap and ensure there is no grease on the outside of the dust cap or hub.(some models have bolt on dust cap with gasket.)
- After assembly, turn the hub to ensure smooth operation.

For replacement parts and repacking procedures please call your dealer. Parts lists for these products can be found online. Visit horstwagons.com and click on the PARTS tab to be directed to our online parts catalogue.



CAUTION
Operational Hazard

Maintenance, adjustments and parts replacement should be made by qualified personnel only.

RUNNING GEAR COMPONENTS:

Inspect running gear components monthly. Unusual play or noise could be an indication of worn parts. Parts replacement should be performed by qualified personnel.

Running gear components should be lubricated or greased yearly unless noted otherwise. Use the following illustrations as a guide to locate the grease zerks on your running gear. Model 325RF is shown, other models are similar depending on the options included.

- Steering Spindles.
- Front Steering Pivot.
- Tie rod ends.
- Lubricate with an good Lithium EP2 grease or equivalent.
- Use a hand-held grease gun for all greasing, one shot of grease is adequate
- Wipe grease zerk with a clean cloth before greasing, to avoid injecting dirt and grit.
- Replace broken zerk fitting immediately.
- If grease zerk will not take grease, remove and thoroughly clean zerk and lubricant passage way.

WAGON MODELS

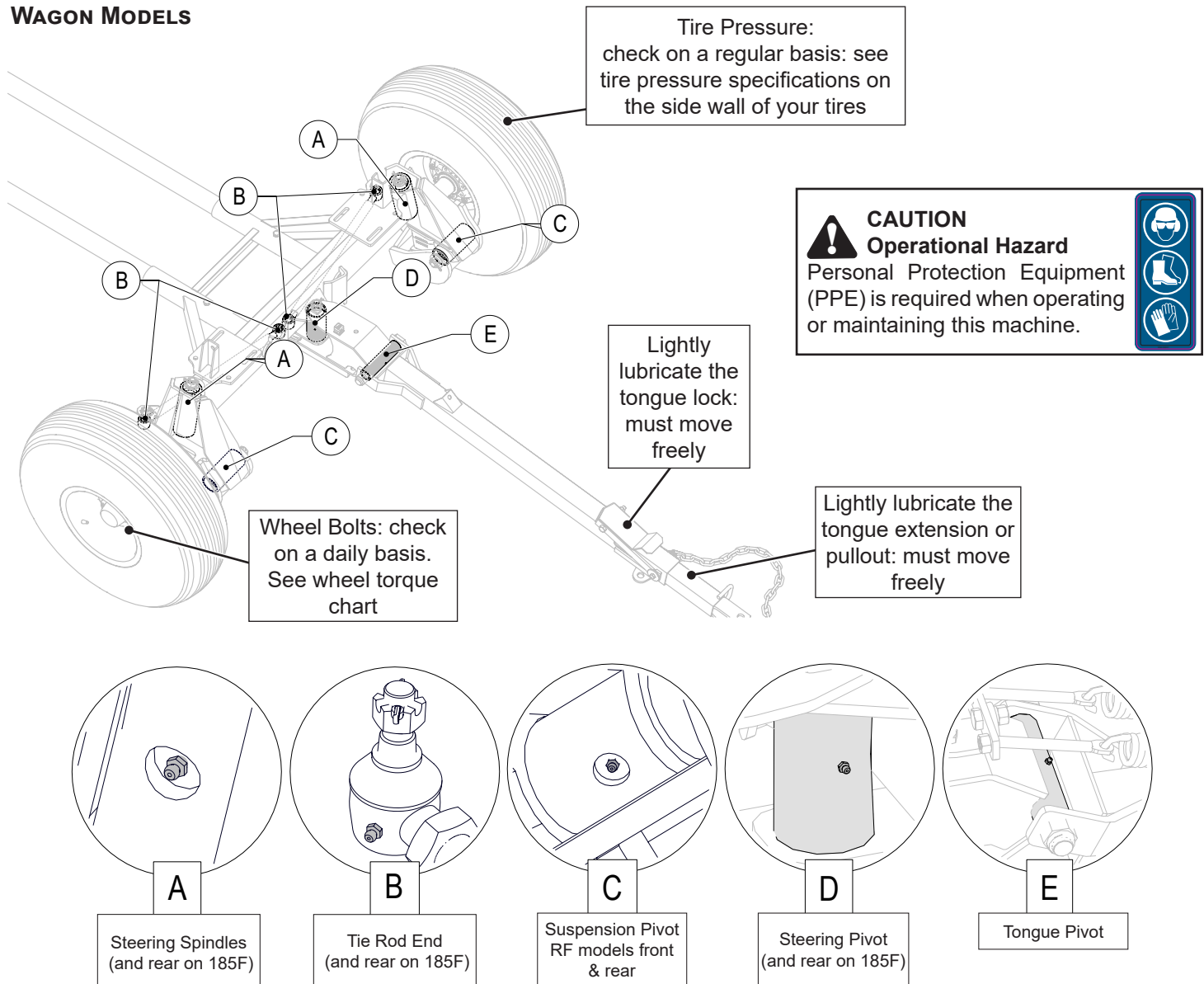

WALKING BEAM MODELS

Walking beam components should be greased yearly. Use the following illustration as a guide to locate the grease zerks on your walking beam. Model 325RF is shown, other models are similar.

Inspect components monthly. Unusual play or noise could be an indication of worn parts. Parts replacement should be performed by qualified personnel.

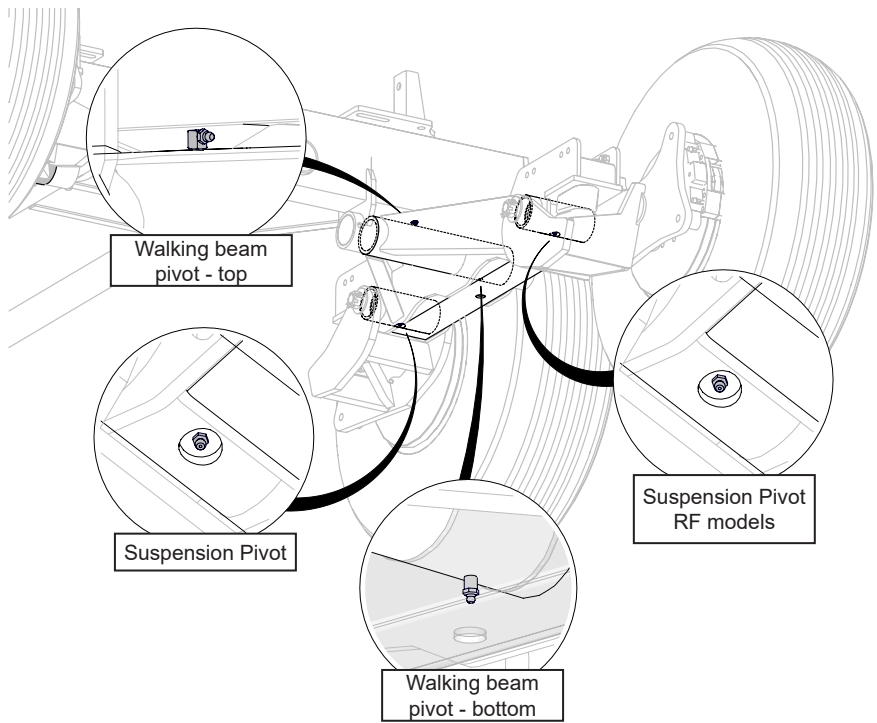

ROCKING BOLSTER:

The rocking bolsters should be thoroughly cleaned regularly to remove dirt and debris and greased yearly.

Use the illustration as a guide to locate the grease zerks on your rocking bolster.

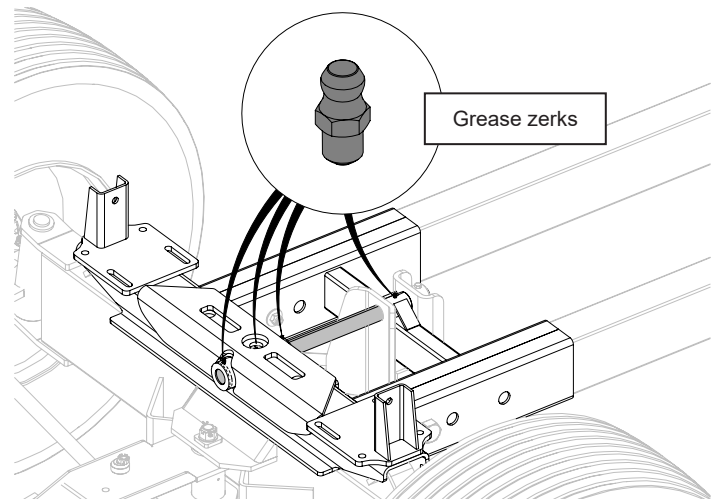

CAUTION Operational Hazard

Maintenance, adjustments and parts replacement should be made by qualified personnel only.

TR505RF & TR605RF - ARTICULATING HITCH

Inspect components monthly. Unusual play or noise could be an indication of worn parts. Parts replacement should be performed by qualified personnel.

Trailer pivoting hitch should be greased every 40 hrs. Use the illustration as a guide to locate the grease zerks on your hitch.

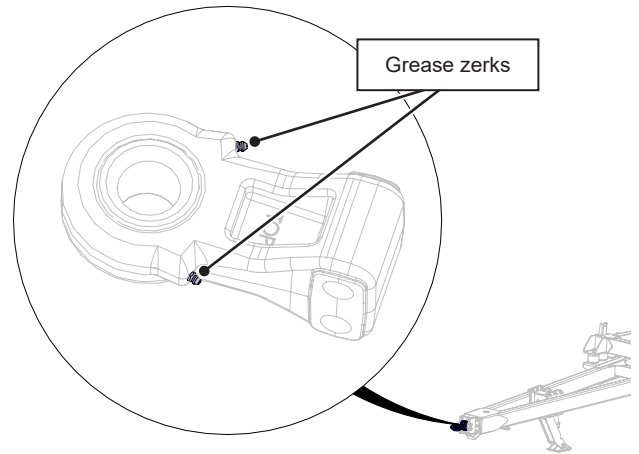

If required the ball joint may be removed for cleaning if the lubricant has become contaminated or replacement is required.

Flip ball joint sideways and pull out from bottom.

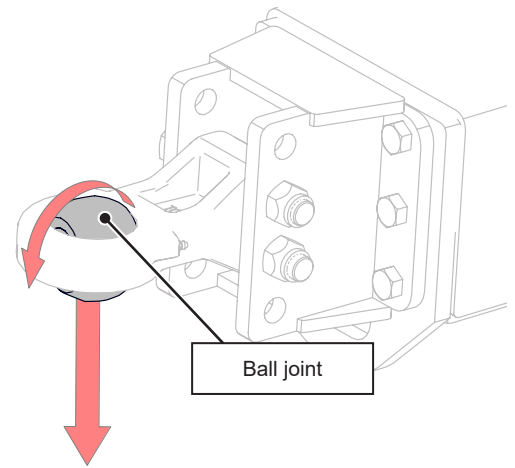

TR505 & TR605 - PIVOTING HITCH

Trailer tongue components should be greased yearly. Use the illustration as a guide to locate the grease zerks on your trailer tongue.

Inspect components monthly. Unusual play or noise could be an indication of worn parts. Parts replacement should be performed by qualified personnel.

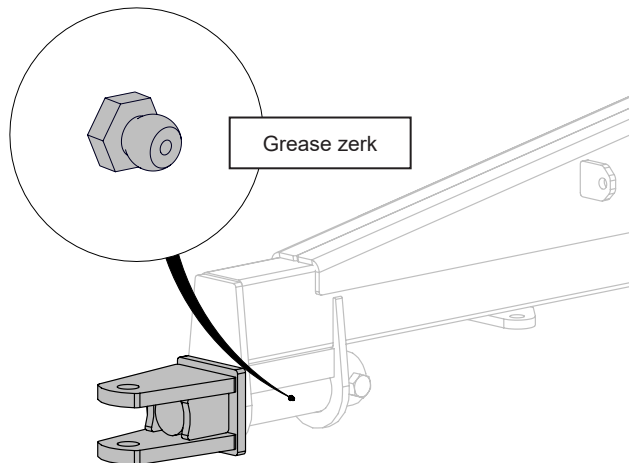

**CAUTION
Operational Hazard**

Maintenance, adjustments and parts replacement should be made by qualified personnel only.

TR505RF & TR605RF - HYDRAULIC JACK

The Hydraulic jack should be thoroughly cleaned on a regular basis to remove dirt and debris.

Jack should be greased yearly or more often under heavy use. Use the illustration as a guide to locate the grease zerks on your trailer jack.

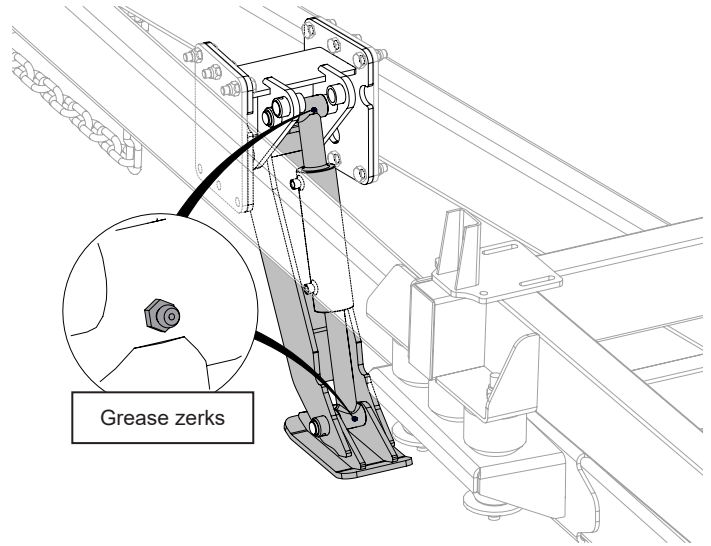

TR505 & TR605 - DROP LEG JACK

The drop leg jack should be thoroughly cleaned regularly and to remove dirt and debris.

Use the illustration as a guide to locate the lubrication points and grease zerks on your trailer jack.

Lightly lubricate moving parts regularly and grease yearly or more often under heavy use.

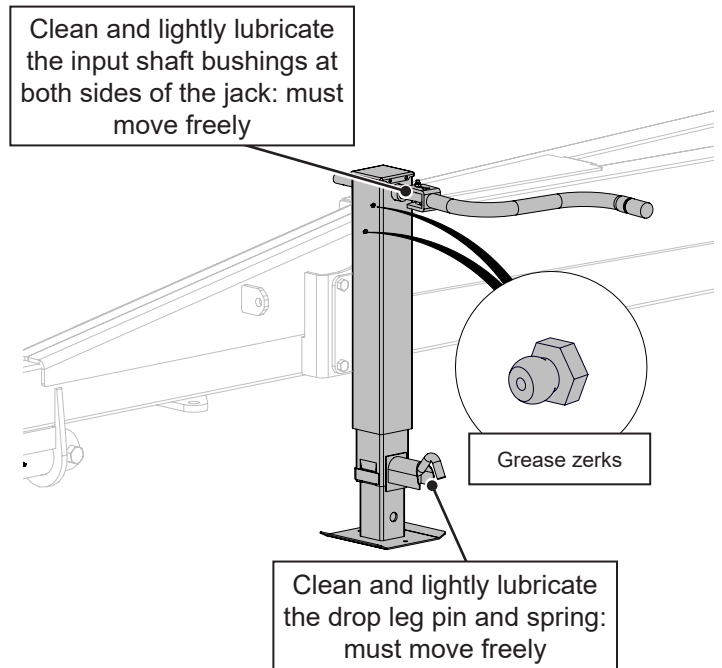

WHEEL ALIGNMENT - WAGONS

When the unit is new the axle is preset at the factory with .3175 - .635 cm (1/8" – 1/4") toe-in and should not require any initial adjustment. Model 185F four wheel steer, has the same toe-in front and rear axle. Adjustment may be required if steering components have been damaged or replaced. Toe in adjustments should be made by qualified personnel.

TRAILING ADJUSTMENT - 185F

Through normal use or after unit has been repaired some maintenance with respect to the tracking alignment may be required.

If the rear axle begins to track excessively left or right of the front axle (dog track), then corrective adjustment is made by lengthening or shortening the joiner tie rod that runs between the tongue bracket steering plate assembly, and the rear centre rod plate.

- Loosen jam nuts at the front and back of the joiner tie rod to allow free rotation of the tie rod.
- Rotate the tie rod to lengthen or shorten as required (see diagram below).
- When adjustment is complete, tighten the jam nuts to secure the setting.
- Test drive the wagon and check for front to rear trailing, repeat adjustment as required.

When the wagon is being trailed empty, it should track slightly left. When the wagon is loaded it may track slightly to the right. The weight causes normal distortion to the steering geometry which affects the tracking when loaded.

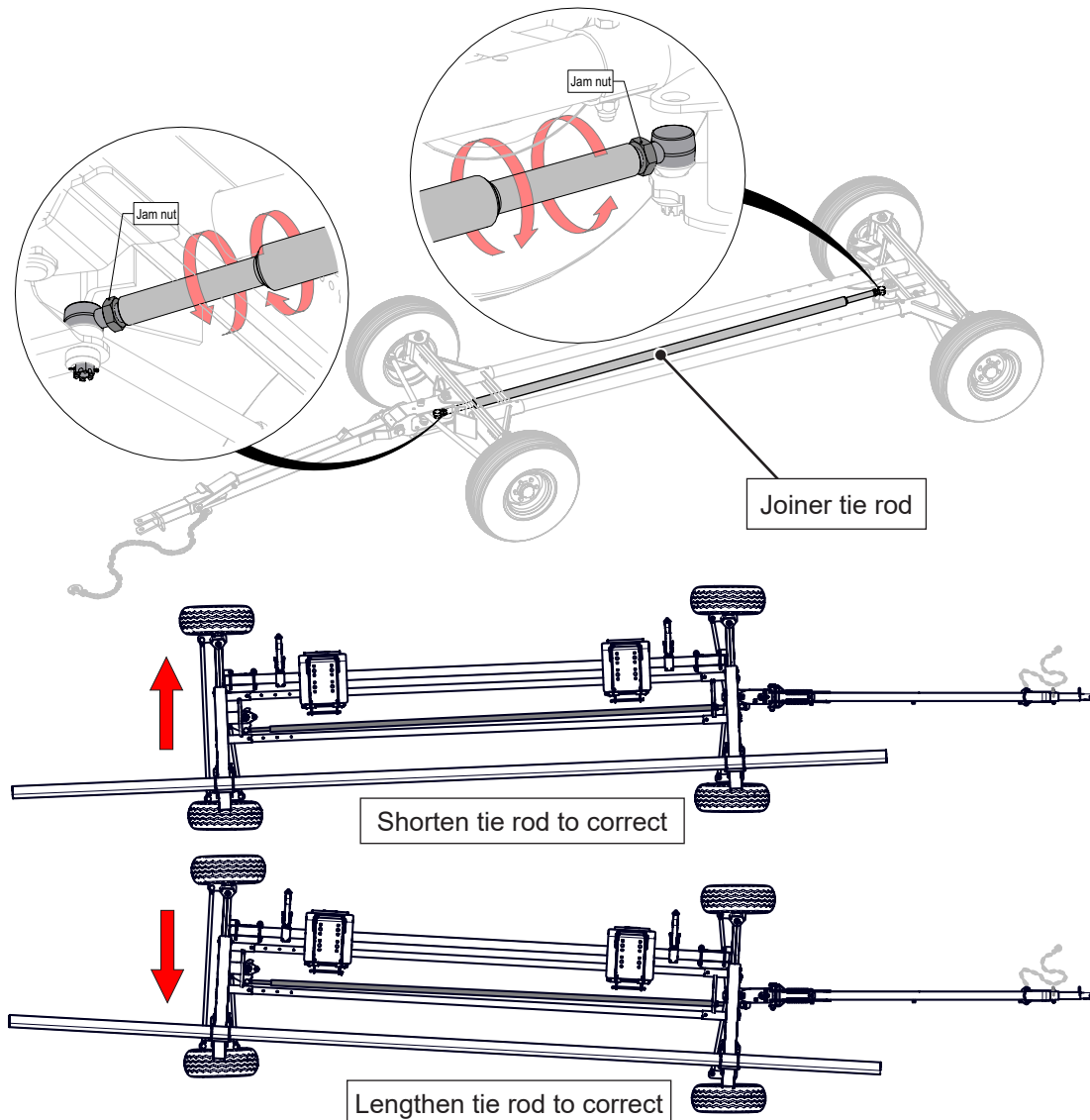

DISC BRAKE MAINTENANCE

Optional feature of 2 or 4 wheel brakes to enhance and aid the safe transport of your running gear. Horst disc brakes are designed to be operated with the dedicated tractor rear hydraulic brake port.

Horst uses non asbestos brake pads. When replacing the brake pads, replace with non asbestos type pads.

As with all brakes periodic maintenance and inspection is required. Brake troubleshooting, maintenance or replacement should be performed by qualified personnel only.

NOTE: INITIAL SERVICE:

Have the brakes inspected and serviced after the first 320 km (200 miles) of operation.

INSPECTION

Brake should be inspected for operation and function each time the wagon is used. If a loss of performance is experienced, the disc brakes must be serviced immediately.

Check for leaks in brake system. Periodic checks should be made on all hoses and fittings to guard against damaged and worn hoses which may cause failure (leaks, rupturing under pressure, and collapsing). Replace defective lines and hoses.

Flush brake system when system is known to be contaminated.

SERVICE

Brake service should be performed by qualified personnel only.

- Brake inspection and service:
 - At 4,800 km (3,000) mile intervals or 1 year,
 - Or as use and performance requires.
- With normal use, servicing at one year intervals is usually adequate. With increased usage, this work should be performed more frequently as required.

- Calliper must be cleaned of dirt and debris.
- Inspect and replace any missing bleeder caps, loose, worn parts, stretched or deformed springs or hardware.
- Pads must be replaced when they become excessively worn or scored, a condition which can reduce vehicle braking.
- Replacement is necessary if the brake pad is worn to 3-2 mm (1/8" - 1/16"). Brake pads contaminated with grease or oil, or abnormally scored or gouged must also be replaced.
- When replacement is necessary, it is important to replace both pads on each brake and both brakes of the same axle. This will help retain the balance of your brakes.
- Brake rotors should be inspected for surface wear, damage and warping.

For replacement parts please call your dealer. Parts lists for these products can be found online. Visit horstwagons.com and click on the PARTS tab to be directed to our online parts catalogue.



WARNING Operational Hazard

Contaminated brake fluid in system could plug fittings and render brakes inoperative resulting in personal injury or death.



CAUTION Operational Hazard

Brake system maintenance and adjustments should be made by qualified personnel only.

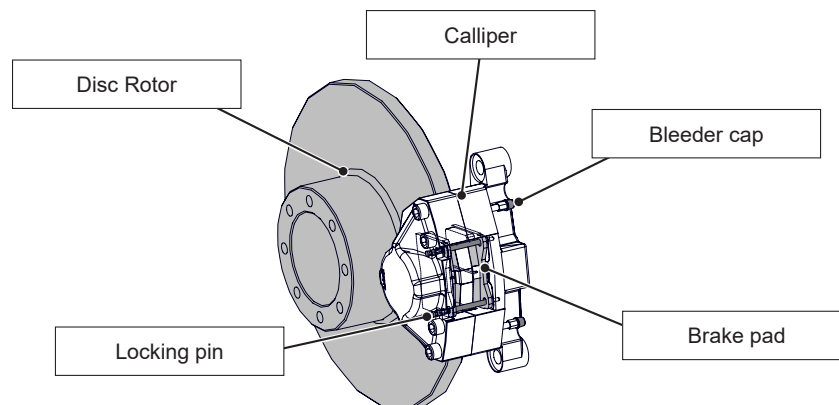

SURGE BRAKE SYSTEM MAINTENANCE

Optional feature of 2 or 4 wheel brakes to enhance and aid the safe transport of your wagon. The drum brakes on your wagon are operated whenever the wagon “pushes” against the tractor while in motion, that in turn causes the brakes to be applied.

Horst uses non asbestos brake pads. When replacing the brake shoes, replace with non asbestos type shoes.

As with all brakes periodic maintenance and inspection is required. Brake troubleshooting, maintenance or replacement should be performed by qualified personnel only.

For replacement parts please call your dealer or contact Horst Wagons.

NOTE: INITIAL SERVICE:

Have the brakes inspected and serviced after the first 320 km (200 miles) of operation when the brake shoes and drums have seated.

INSPECTION

Brake should be inspected for operation and function each time the wagon is used. If a loss of performance is experienced, the surge brakes must be serviced immediately.

Check for leaks in brake system. Periodic checks should be made on all hoses and fittings to guard against damaged or worn hoses which may cause failure (leaks, rupturing under pressure, and collapsing). Replace defective lines and hoses.

Flush brake system when system is known to be contaminated.

SERVICE

Brake service should be performed by qualified personnel only.

- Brakes should be adjusted and the drum removed for inspection and service:
 - At 4,800 km (3,000) mile intervals or 1 year,
 - Or as use and performance requires.
- With normal use, servicing at one year intervals is usually adequate. With increased usage, this work should be performed more frequently as required.

- Backing plate, shoe adjuster, and brake shoes must be cleaned.
- Inspect and replace any loose, worn parts, stretched or deformed springs or hardware.
- Shoes must be changed when they become excessively worn or scored, a condition which can reduce vehicle braking.
- Replacement is necessary if the brake shoe is worn to 3 mm (1/16”) or less. Brake shoes contaminated with grease or oil, or abnormally scored or gouged must also be replaced.
- When replacement is necessary, it is important to replace both shoes on each brake and both brakes of the same axle. This will help retain the balance of your brakes.
- Brake drums should be inspected for surface wear or damage and out of round wear.

For replacement parts please call your dealer. Parts lists for these products can be found online. Visit horstwagons.com and click on the PARTS tab to be directed to our online parts catalogue.



CAUTION Operational Hazard

Brake system maintenance and adjustments should be made by qualified personnel only.

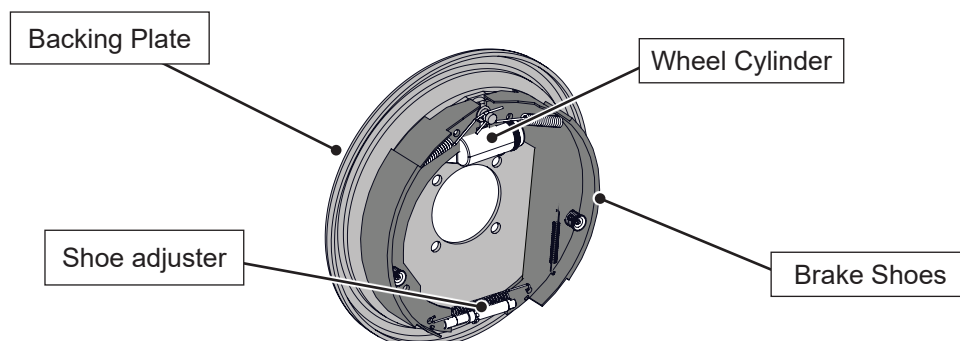

BRAKE FLUID

Brake reservoir should be inspected and filled to three quarter full. Check the fluid for contamination and replace if required.

Use DOT-3 brake fluid.

If fluid replacement is required, see the fill and bleed instructions in the wagon assembly manual, also available on line.

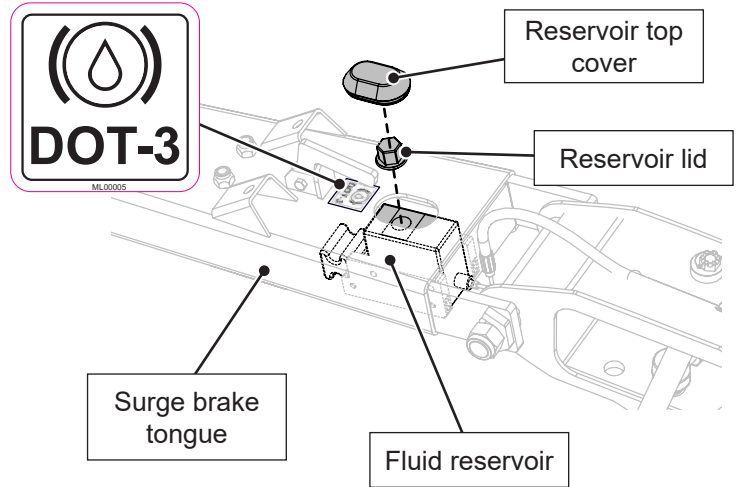

WARNING Operational Hazard

Contaminated brake fluid in system could plug fittings and render brakes inoperative resulting in personal injury or death.

SURGE BRAKE TONGUE

Keep tongue and all moving parts clean and lubricated to prevent rusting and ensure ease of operation.

Keep clean, remove debris and use SAE 30 oil to lubricate: see illustration

- Bleeder handle
- Stop bolt
- Mid tongue assembly

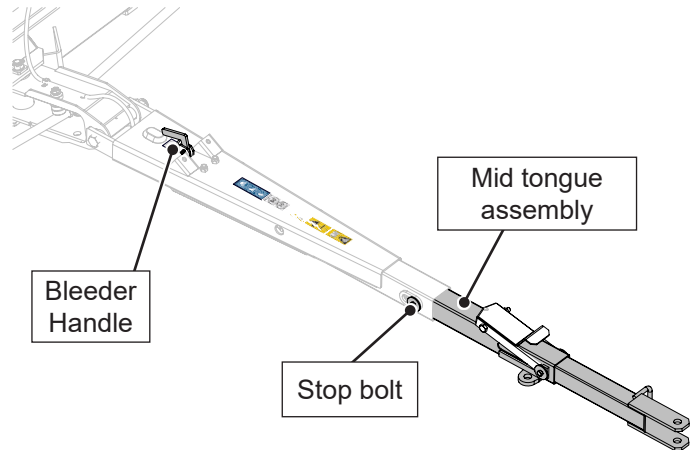

CAUTION Operational Hazard

Brake system maintenance and adjustments should be made by qualified personnel only.

BOLT TORQUE TABLE

These tables are offered as the suggested maximum torque values for dry (not lubricated) threaded products and are only a general guide.

Check tightness of bolts periodically, replace hardware with the same strength bolt.

Torque specification for bolts are identified by their head markings as shown.

See the "Wheel Torque Specification" page for wheel bolt /nut torque settings.

METRIC TORQUE SPECIFICATIONS

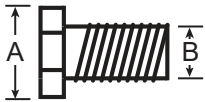

Wrench Size: "A"	Thread Size: "B" Fine	Class 8.8		Class 10.9		Thread Size: "B" Coarse	Class 8.8		Class 10.9	
		N-m	lbs-ft	N-m	lbs-ft		N-m	lbs-ft	N-m	lbs-ft
10 mm	6 x 0.75	---	---	---	---	6 x 1.0	11.3	8.3	16.5	12.2
13 mm	8 x 1.0	27	20	38	28	8 x 1.25	27.3	20.1	40.1	29.6
16 mm	10 x 1.25	52	38	73	54	10 x 1.5	54	40	49	36
18 mm	12 x 1.25	95	70	135	100	12.1.75	93	69	137	101
21 mm	14 x 1.5	150	111	210	155	14 x 2.0	148	109	218	161
24 mm	16 x 1.5	225	166	315	232	16 x 2.0	230	170	338	249
27 mm	18 x 1.5	325	240	460	339	18 x 2.5	329	243	469	346
30 mm	20 x 1.5	460	339	640	472	20 x 2.5	464	342	661	487
34 mm	22 x 1.5	610	450	860	634	22 x 2.5	634	468	904	667
36 mm	24 x 2.0	780	575	1100	811	24 x 3.0	798	588	1136	838
41 mm	27 x 3.0	---	---	---	---	27 x 3.0	1176	867	1674	1234
46 mm	30 x 2.0	---	---	---	---	30 x 3.0	1597	1178	2274	1677

SAE TORQUE SPECIFICATIONS

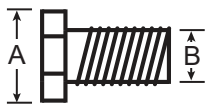

Wrench Size: "A"	Thread Size: "B" Fine	SAE 2		SAE 5		SAE 8		Thread Size: "B" Coarse	SAE 2		SAE 5		SAE 8	
		lbs-ft	N-m	lbs-ft	N-m	lbs-ft	N-m		lbs-ft	N-m	lbs-ft	N-m	lbs-ft	N-m
7/16"	1/4-28	6	8.1	10	13.6	14	19.0	1/4-20	5	6.8	8	10.8	12	16.3
1/2"	5/16-24	13	17.6	19	25.7	27	36.6	5/16-18	11	14.9	17	23.0	25	33.9
9/16"	3/8-24	23	31.2	35	47.4	49	66.4	3/8-16	20	27.1	31	42.0	44	59.6
5/8"	7/16-20	36	48.8	55	74.5	75	101.6	7/16-14	32	43.4	49	66.4	70	94.9
3/4"	1/2-20	55	74.5	85	115.2	120	162.6	1/2-13	49	66.4	75	101.6	107	145.0
13/16"	9/16-18	79	107.0	122	165.3	172	233.1	9/16-12	70	94.9	109	147.7	154	208.7
15/16"	5/8-18	110	149.1	170	230.4	240	325.2	5/8-11	97	131.4	150	203.3	212	287.3
1-1/8"	3/4-16	192	260.2	297	402.4	420	569.1	3/4-10	173	234.4	266	360.4	376	509.5
1-5/16"	7/8-14	184	249.3	474	642.3	668	905.1	7/8-9	166	224.9	429	581.3	606	821.1
1-1/2"	1.0-12	274	371.3	705	955.3	995	1348.2	1.0-8	250	338.8	644	872.6	909	1231.7

WHEEL TORQUE SPECIFICATION

It is an extremely important safety procedure to apply and maintain proper wheel mounting torque on your trailer axle. Torque wrenches are the best method to assure the proper amount of torque is being applied to a fastener.

Wheel lugs should be torqued before first road use and after each wheel removal. Check and re torque after the first 10 miles, 25 miles, and again at 50 miles. Check periodically thereafter.

Note: Wheel lugs must be applied and maintained at the proper torque levels to prevent loose wheels, broken studs, and possible dangerous separation of wheels from your axle.

1. Start all lugs by hand to prevent cross threading.
2. Tighten lugs in sequence, as shown in the diagram.
3. Tighten the lugs - see chart

Wheel Nut / Bolt Size	Torque Dry		Torque Lubricated	
	lbs-ft	N-m	lbs-ft	N-m
1/2"	90	122	65	88
1/2" (brake drum)	100	136	75	102
9/16"	120	163	90	122
5/8"	180	244	130	176
3/4"	300	407	220	298

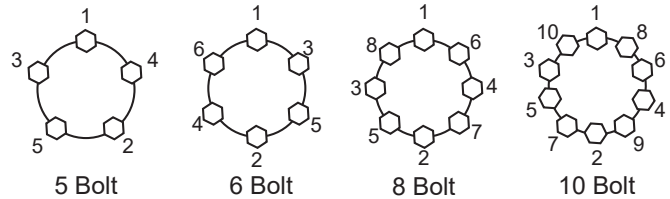

Wheel Lug Torque Sequence

TIRE PRESSURE

Check tire pressure on a regular basis, see tire pressure specifications on the side wall of your tires.

It is important that tires are inspected after unit is loaded. Do not exceed maximum recommended tire pressure.

TROUBLE SHOOTING

On the following page, we have listed many of the causes and solutions to issues that you may encounter.

If you encounter a issue that is difficult to solve, even after having read through this trouble shooting section, please call your local distributor or dealer. Before you call, please have this Operator's Manual and serial number ready

WAGON / TRAILER

Issue	Cause	Solution
The wagon sways while being towed.	There are 2 reach tubes that run the length of the wagon. The reach tubes are fastened to the front and rear axle assemblies by 1 bolt at each end for each of the tubes. If any of these bolts are loose then there will be end play causing sway.	Tighten and torque the bolts and ensure that the bolts are held in place with lock nuts. Lock nuts will prevent loosening of the bolts.
	Travelling faster than what speed it is designed for.	The wagon design has a travel speed rating at or below 50 km/h (35 MPH). Stay at or below the travel speed rating.
	Worn steering components	check for excessive play in the - wheel bearing - steering spindles - ball joints - tongue pivots replace any bearings that are worn
	Toe in setting is out of specification	Have a qualified person adjust the toe-in. The factory setting is .3175 - .635 cm (1/8" - 1/4") toe-in
Rapid or unusual tire wear.	Worn steering components	Check for wear or excessive play in - wheel bearings - steering spindles - ball joints replace any components that are worn out
	Toe in setting is out of specification	Have a qualified person adjust the toe-in. The factory setting for both axles should be .3175 - .635 cm (1/8" - 1/4") tow-in
	Tire rim bent	Check tire rims for wobble while rotating, replace if bent.
	Improper tire for application	Check that your tire type matches your application. Example: Ag tires used consistently on highway will wear prematurely. Replace tires with correct type.

BRAKES

Issue	Cause	Solution
BRAKE NOISE	Shoe / pad chatter, lining coated with grease	Correct cause of grease leakage, clean drums / discs, replace brake shoes / pads.
	Vibration with loose bolts, out-of-round drums / warped disc	Tighten hub bolts, recondition or replace drum / disc.
	Vibration with loose bearing adjustment or rough bearing	Replace drums / discs.
	Brakes Dragging / Lock-Up	Flush the brake system Overhaul wheel cylinders / calipers or replace. Install new spring & pin kit (surge brake)
	Surge brake drums hot / one or more brakes drag: unequal pressure	Re-adjust the brakes. Be sure each brake assembly has the same adjustment to equalize the brake pressure for each wheel.
EXCESSIVE TRAVEL OF TONGUE BRAKE ACTUATOR	Leaks in hydraulic lines / hoses	Replace defective lines / hoses.
	Low fluid in master cylinder reservoir / air in hydraulic lines	Top up master cylinder Bleed system of air contamination.
	Leaking wheel cylinders	Overhaul wheel cylinders or replace.
	Leaking master cylinder / orifice restricted with dirt / defective line or hoses.	Check all components and make repair or replace as required.
	Excessive lining-to-drum clearance	Adjust or replace shoes.
PRESSURE BUILD-UP IN SYSTEM	Contaminated fluid causing blockages.	Drain & flush brake system, and replace fluid.
	Mid tongue assembly jamming / siezed / weak or damaged return spring.	Check mid tongue actuator assembly, free up and lubricate. Check spring replace if required.
	Hose / line collapsed, keeping fluid from returning to master cylinder	Replace defective hose / line.
	Surge master cylinder restricted with dirt, or weak return spring	Check all components, overhaul or replace.
	Disc caliper siezed, not returning piston	Check all calipers, overhaul or replace.
	Disc brake hose coupler not connected to coupler holder	Connect to coupler holder to relieve pressure in the brake system.

PAYLOAD AND GVWR CHART

This chart shows the GVWR of each wagon model based on the capacity rating of tire options available from Horst Wagons. Replacement tires must have the same or similar tire specifications.

Payload is shown based on travel speed and tire option. In some cases payload is reduced for travel speed greater than 30 km/h (20 mile/h). Wagon service brakes are recommended when travelling with a full load at speeds greater than 30 km/h (20 mile/h).

Curb Weight = is the sum of the ((tire + rim weight) x # hubs) + chassis weight

Payload = is the maximum weight of the load allowed.

Wagon GVWR = based on capacity rating of the tire x # hubs.

Note: If there is a material handling platform (gravity bin, hay rack etc) installed on the wagon that weight must also be subtracted from the 'Payload'.

Running Gear Model		Tire Options		All weights are in lbs				
Wagon	Tire Size	Tire Type	Wagon GVWR based on Tire Capacity x # Axles	-	Curb Weight Chassis + tire & rim Weight	=	Payload Travel speed rating - Low max 30 km/h (20 mile/h)	Payload Travel speed rating - High max 50 km/h (30 mile/h)
145 (8 ton)	11L x 15	8 Ply	10160		835		9325	9325
	225/75 R15	D Range	10160		735		9425	9425
	12.5L x 15	12 Ply	14560		903		13657	11097
	245 R16	Used Truck / New Tubes	14000		807		13193	11193
	11L x 15	D Range / Hwy Ser.	12480		867		11613	11133
185 (10 ton)	11L x 15	F Range / Hwy Ser.	15840		891		14949	11109
	26 x 12	12 Ply	11000		707		10293	10293
	11L x 15	8 Ply	10160		1040		9120	9120
	225/75 R15	D Range	10160		940		9220	9220
	12.5L x 15	12 Ply	14560		1108		13452	13452
185F (6 ton)	245 R16	Used Truck / New Tubes	14000		1012		12988	12988
	11L x 15	D Range / Hwy Ser.	12480		1072		11408	11408
	11L x 15	F Range / Hwy Ser.	15840		1096		14744	14744
	11L x 15	8 Ply	10160		1300		8860	8860
	225/75 R15	D Range	10160		1200		8960	8960
205 (12 ton)	12.5L x 15	12 Ply	12000		1368		10632	10632
	245 R16	Used Truck / New Tubes	12000		1272		10728	10728
	11L x 15	F Range / Hwy Ser.	12000		1356		10644	10644
	12.5L x 16	14 Ply	16720		1205		15515	15515
	12.5L x 15	F Range / Hwy Ser.	18720		1297		17423	16703
	14L x 16.1	8 Ply	15440		1305		14135	14135
	14L x 16.1	12 Ply	18720		1365		17355	16635
	16.5 x 16.1	10 Ply	20800		1485		19315	16515
	11 x 22.5	Used Truck	24000		1705		22295	16295
	11 x 22.5	New Recap	24000		1705		22295	16295
	12 or 315 x 22.5	Used Truck	24000		1213		22787	16787
	12 or 315 x 22.5	New Recap	24000		1769		22231	16231
	305 x 22.5	Used Truck	24000		1817		22183	16183
	305 x 22.5	New Recap	24000		1817		22183	16183
	385 x 22.5	Used Truck	24000		1949		22051	16051
385 x 22.5	New Recap	24000		1949		22051	16051	
275 (14 ton)	425 x 22.5	Used Truck	24000		2089		21911	15911
	425 x 22.5	New Recap	24000		2089		21911	15911
	425 x 22.5	New Truck	24000		2089		21911	15911
	14L x 16.1	8 Ply	15440		1475		13965	13965
	14L x 16.1	12 Ply	18720		1535		17185	17185
	16.5 x 16.1	10 Ply	20800		1655		19145	19145
	19L x 16.1	10 Ply	24000		1739		22261	22261
	21.5 x 16.1	14 Ply	28000		1811		26189	22189
	11 x 22.5	Used Truck	28000		1875		26125	22125
	11 x 22.5	New Recap	28000		1875		26125	22125
	12 or 315 x 22.5	Used Truck	28000		1939		26061	22061
	12 or 315 x 22.5	New Recap	28000		1939		26061	22061
	305 x 22.5	Used Truck	28000		1987		26013	22013
	305 x 22.5	New Recap	28000		1987		26013	22013
	385 x 22.5	Used Truck	28000		2131		25869	21869
385 x 22.5	New Recap	28000		2131		25869	21869	
400 / 55 x 22.5	425 x 22.5	Used Truck	28000		2271		25729	21729
	425 x 22.5	New Recap	28000		2271		25729	21729
	425 x 22.5	New Truck	28000		2271		25729	21729
	425 x 22.5	Used Truck	28000		2287		25713	21713
	425 x 22.5	New Recap	28000		2287		25713	21713
	425 x 22.5	New Truck	28000		2287		25713	21713
	445/50 x 22.5	New Recap	28000		1487		26513	22513
	445 x 22.5	New Truck	28000		1487		26513	22513
	400 / 55 x 22.5	16 Ply	28000		2015		25985	21985

continued

Running Gear Model	Tire Options		All weights are in lbs				
			Wagon GVWR based on Tire Capacity x # Axles	- Curb Weight Chassis + tire & rim Weight	=	Payload Travel speed rating - Low max 30 km/h (20 mile/h)	Payload Travel speed rating - High max 50 km/h (30 mile/h)
Wagon	Tire Size	Tire Type					
285 (15 ton)	16.5 x 16.1	10 Ply	20800	2085		18715	18715
	19L x 16.1	10 Ply	24000	2169		21831	21831
	21.5 x 16.1	14 Ply	30000	2241		27759	21759
	11 x 22.5	Used Truck	30000	2305		27695	21695
	11 x 22.5	New Recap	30000	2305		27695	21695
	12 or 315 x 22.5	Used Truck	30000	2369		27631	21631
	12 or 315 x 22.5	New Recap	30000	2369		27631	21631
	305 x 22.5	Used Truck	30000	2417		27583	21583
	305 x 22.5	New Recap	30000	2417		27583	21583
	385 x 22.5	Used Truck	30000	2561		27439	21439
	385 x 22.5	New Recap	30000	2561		27439	21439
	425 x 22.5	Used Truck	30000	2717		27283	21283
	425 x 22.5	New Recap	30000	2717		27283	21283
	425 x 22.5	New Truck	30000	2717		27283	21283
	445/50 x 22.5	New Recap	30000	1917		28083	22083
	445 x 22.5	New Truck	30000	1917		28083	22083
400 / 55 x 22.5	16 Ply	30000	2445		27555	21555	
560 / 45 x 22.5	16 Ply	30000	1925		28075	22075	
365 (20 ton)	16.5 x 16.1	10 Ply	20800	2235		18565	18565
	19L x 16.1	10 Ply	24000	2319		21681	21681
	21.5 x 16.1	14 Ply	31400	2391		29009	29009
	425 x 22.5	Used Truck	40000	2867		37133	33133
	425 x 22.5	New Recap	40000	2867		37133	33133
	425 x 22.5	New Truck	40000	2867		37133	33133
	445/50 x 22.5	New Recap	40000	2067		37933	33933
	445 x 22.5	New Truck	40000	2067		37933	33933
	400 / 55 x 22.5	16 Ply	31280	2595		28685	28685
	560 / 45 x 22.5	16 Ply	38560	2075		36485	33925
	365E (20 ton)	16.5 x 16.1	10 Ply	20800	2135		18665
19L x 16.1	10 Ply	24000	2219		21781	21781	
21.5 x 16.1	14 Ply	31400	2291		29109	29109	
425 x 22.5	Used Truck	40000	2767		37233	33233	
425 x 22.5	New Recap	40000	2767		37233	33233	
425 x 22.5	New Truck	40000	2767		37233	33233	
445/50 x 22.5	New Recap	40000	1967		38033	34033	
445 x 22.5	New Truck	40000	1967		38033	34033	
400 / 55 x 22.5	16 Ply	31280	2495		28785	28785	
560 / 45 x 22.5	16 Ply	38560	1975		36585	34025	
485 (24 ton)	425 x 22.5	Used Truck	48000	3542		44458	44458
	425 x 22.5	New Recap	48000	3542		44458	44458
	425 x 22.5	New Truck	48000	3542		44458	44458
	445 x 22.5	Used Truck	48000	2742		45258	45258
	445/50 x 22.5	New Recap	48000	2742		45258	45258
	445 x 22.5	New Truck	48000	2742		45258	45258
	400 / 55 x 22.5	16 Ply	31280	3270		28010	28010
	560 / 45 x 22.5	16 Ply	38560	2710		35850	35850
185RF (10 ton)	11L x 15	8 Ply	10160	1450		8710	8710
	225/75 R15	D Range	10160	1350		8810	8810
	12.5L x 15	12 Ply	14560	1518		13042	13042
	245 R16	Used Truck / New Tubes	14000	1422		12578	12578
	11L x 15	D Range / Hwy Ser.	12480	1482		10998	10998
	11L x 15	F Range / Hwy Ser.	15840	1506		14334	14334
	205RF (12 ton)	12.5L x 16	14 Ply	16720	1630		15090
12.5L x 15	F Range / Hwy Ser.	18720	1722		16998	16278	
14L x 16.1	8 Ply	15440	1730		13710	13710	
14L x 16.1	12 Ply	18720	1790		16930	16210	
16.5 x 16.1	10 Ply	20800	1910		18890	16090	
11 x 22.5	Used Truck	24000	2130		21870	15870	
11 x 22.5	New Recap	24000	2130		21870	15870	
12 or 315 x 22.5	Used Truck	24000	2194		21806	15806	
12 or 315 x 22.5	New Recap	24000	2194		21806	15806	
305 x 22.5	Used Truck	24000	2242		21758	15758	
305 x 22.5	New Recap	24000	2242		21758	15758	
385 x 22.5	Used Truck	24000	2374		21626	15626	
385 x 22.5	New Recap	24000	2374		21626	15626	
425 x 22.5	Used Truck	24000	2514		21486	15486	
425 x 22.5	New Recap	24000	2514		21486	15486	
425 x 22.5	New Truck	24000	2514		21486	15486	

Note: If there is a platform or bin attached to the wagon that weight must also be subtracted from the 'Payload'.
continued

Running Gear Model		Tire Options		All weights are in lbs					
Wagon	Tire Size	Tire Type	Wagon GVWR based on Tire Capacity x # Axles	-	Curb Weight Chassis + tire & rim Weight	=	Payload Travel speed rating - Low max 30 km/h (20 mile/h)	Payload Travel speed rating - High max 50 km/h (30 mile/h)	
285RF (15 ton)	16.5 x 16.1	10 Ply	20800		3725		17075	17075	
	19L x 16.1	10 Ply	24000		3809		20191	20191	
	21.5 x 16.1	14 Ply	30000		3881		26119	20119	
	11 x 22.5	Used Truck	30000		3945		26055	20055	
	11 x 22.5	New Recap	30000		3945		26055	20055	
	12 or 315 x 22.5	Used Truck	30000		4009		25991	19991	
	12 or 315 x 22.5	New Recap	30000		4009		25991	19991	
	305 x 22.5	Used Truck	30000		4057		25943	19943	
	305 x 22.5	New Recap	30000		4057		25943	19943	
	385 x 22.5	Used Truck	30000		4201		25799	19799	
	385 x 22.5	New Recap	30000		4201		25799	19799	
	425 x 22.5	Used Truck	30000		4357		25643	19643	
	425 x 22.5	New Recap	30000		4357		25643	19643	
	425 x 22.5	New Truck	30000		4357		25643	19643	
	445/50 x 22.5	New Recap	30000		3557		26443	20443	
	445 x 22.5	New Truck	30000		3557		26443	20443	
	400 / 55 x 22.5	16 Ply	30000		4085		25915	19915	
	560 / 45 x 22.5	16 Ply	30000		3565		26435	20435	
	365RF (20 ton)	16.5 x 16.1	10 Ply	20800		4145		16655	16655
		19L x 16.1	10 Ply	24000		4229		19771	19771
21.5 x 16.1		14 Ply	31400		4301		27099	27099	
425 x 22.5		Used Truck	40000		4777		35223	31223	
425 x 22.5		New Recap	40000		4777		35223	31223	
425 x 22.5		New Truck	40000		4777		35223	31223	
445/50 x 22.5		New Recap	40000		3977		36023	32023	
445 x 22.5		New Truck	40000		3977		36023	32023	
400 / 55 x 22.5		16 Ply	31280		4505		26775	26775	
560 / 45 x 22.5		16 Ply	38560		3985		34575	32015	
485RF (24 ton)	425 x 22.5	Used Truck	48000		5702		42298	42298	
	425 x 22.5	New Recap	48000		5702		42298	42298	
	425 x 22.5	New Truck	48000		5702		42298	42298	
	445 x 22.5	Used Truck	48000		4902		43098	43098	
	445/50 x 22.5	New Recap	48000		4902		43098	43098	
	445 x 22.5	New Truck	48000		4902		43098	43098	
	400 / 55 x 22.5	16 Ply	31280		5430		25850	25850	
	560 / 45 x 22.5	16 Ply	38560		4870		33690	33690	
TR505RF	16.5 x 16.1	10 Ply	20800		5910		14890	14890	
	19L x 16.1	10 Ply	24000		5994		18006	18006	
	21.5 x 16.1	14 Ply	31400		6066		25334	25334	
	425 x 22.5	Used Truck	40000		6542		33458	29458	
	425 x 22.5	New Recap	40000		6542		33458	29458	
	425 x 22.5	New Truck	40000		6542		33458	29458	
	445 x 22.5	Used Truck	40000		5742		34258	30258	
	445/50 x 22.5	New Recap	40000		5742		34258	30258	
	445 x 22.5	New Truck	40000		5742		34258	30258	
	400 / 55 x 22.5	16 Ply	31280		6270		25010	25010	
560 / 45 x 22.5	16 Ply	38560		5750		32810	30250		
TR605RF	425 x 22.5	Used Truck	48000		7217		40783	40783	
	425 x 22.5	New Recap	48000		7217		40783	40783	
	425 x 22.5	New Truck	48000		7217		40783	40783	
	445 x 22.5	Used Truck	48000		6417		41583	41583	
	445/50 x 22.5	New Recap	48000		6417		41583	41583	
	445 x 22.5	New Truck	48000		6417		41583	41583	
	400 / 55 x 22.5	16 Ply	31280		6945		24335	24335	
560 / 45 x 22.5	16 Ply	38560		6385		32175	32175		
245 (12 ton)	11L x 15	8 Ply	15240		1435		13805	13805	
	225/75 R15	D Range	15240		1285		13955	13955	
	12.5L x 15	12 Ply	21840		1537		20303	20303	
	12.5L x 16	14 Ply	24000		1525		22475	22475	
	245 R16	Used Truck / New Tubes	21000		1393		19607	19607	
	11L x 15	D Range / Hwy Ser.	18720		1483		17237	17237	
	11L x 15	F Range / Hwy Ser.	23760		1519		22241	22241	
265 (14 ton)	12.5L x 15	12 Ply	21840		1707		20133	20133	
	12.5L x 16	14 Ply	25080		1695		23385	23385	
	12.5L x 15	F Range / Hwy Ser.	28080		1833		26247	25167	
	14L x 16.1	8 Ply	23160		1845		21315	21315	
	14L x 16.1	12 Ply	28080		1935		26145	25065	

Note: If there is a platform or bin attached to the wagon that weight must also be subtracted from the 'Payload'.

continued

Running Gear Model	Tire Options		All weights are in lbs				
			Wagon GVWR based on Tire Capacity x # Axles	- Curb Weight Chassis + tire & rim Weight	=	Payload Travel speed rating - Low max 30 km/h (20 mile/h)	Payload Travel speed rating - High max 50 km/h (30 mile/h)
Wagon	Tire Size	Tire Type					
325 (18 ton)	14L x 16.1	12 Ply	28080	2275		25805	25805
	16.5 x 16.1	10 Ply	31200	2455		28745	28745
	19L x 16.1	10 Ply	36000	2581		33419	33419
	21.5 x 16.1	14 Ply	36000	2689		33311	33311
	11 x 22.5	Used Truck	36000	2785		33215	33215
	11 x 22.5	New Recap	36000	2785		33215	33215
	12 or 315 x 22.5	Used Truck	36000	2881		33119	33119
	12 or 315 x 22.5	New Recap	36000	2881		33119	33119
	305 x 22.5	Used Truck	36000	2953		33047	33047
	305 x 22.5	New Recap	36000	2953		33047	33047
	385 x 22.5	Used Truck	36000	3169		32831	32831
	385 x 22.5	New Recap	36000	3169		32831	32831
	425 x 22.5	Used Truck	36000	3379		32621	32621
	425 x 22.5	New Recap	36000	3379		32621	32621
	425 x 22.5	New Truck	36000	3379		32621	32621
	425 x 22.5	Used Truck	36000	3403		32597	32597
	425 x 22.5	New Recap	36000	3403		32597	32597
	425 x 22.5	New Truck	36000	3403		32597	32597
	445/50 x 22.5	New Recap	36000	2203		33797	33797
	445 x 22.5	New Truck	36000	2203		33797	33797
400 / 55 x 22.5	16 Ply	36000	2995		33005	33005	
505 (22 ton)	16.5 x 16.1	10 Ply	31200	5465		25735	25735
	19L x 16.1	10 Ply	36000	5591		30409	30409
	21.5 x 16.1	14 Ply	44000	5699		38301	38301
	425 x 22.5	Used Truck	72000	6413		65587	37587
	425 x 22.5	New Recap	72000	6413		65587	37587
	425 x 22.5	New Truck	72000	6413		65587	37587
	445/50 x 22.5	New Recap	72000	5213		66787	38787
	445 x 22.5	New Truck	72000	5213		66787	38787
	400 / 55 x 22.5	16 Ply	46920	6005		40915	37995
	560 / 45 x 22.5	16 Ply	57840	5225		52615	52615
605 (30 ton)	425 x 22.5	Used Truck	60000	5293		54707	54707
	425 x 22.5	New Recap	60000	5293		54707	54707
	425 x 22.5	New Truck	60000	5293		54707	54707
	445 x 22.5	Used Truck	60000	4093		55907	55907
	445/50 x 22.5	New Recap	60000	4093		55907	55907
	445 x 22.5	New Truck	60000	4093		55907	55907
	400 / 55 x 22.5	16 Ply	46920	4885		42035	42035
	560 / 45 x 22.5	16 Ply	57840	4045		53795	53795
325RF (18 ton)	14L x 16.1	12 Ply	28080	2965		25115	25115
	16.5 x 16.1	10 Ply	31200	3145		28055	28055
	19L x 16.1	10 Ply	36000	3271		32729	32729
	21.5 x 16.1	14 Ply	36000	3379		32621	32621
	11 x 22.5	Used Truck	36000	3475		32525	32525
	11 x 22.5	New Recap	36000	3475		32525	32525
	12 or 315 x 22.5	Used Truck	36000	3571		32429	32429
	12 or 315 x 22.5	New Recap	36000	3571		32429	32429
	305 x 22.5	Used Truck	36000	3643		32357	32357
	305 x 22.5	New Recap	36000	3643		32357	32357
	385 x 22.5	Used Truck	36000	3859		32141	32141
	385 x 22.5	New Recap	36000	3859		32141	32141
	425 x 22.5	Used Truck	36000	4069		31931	31931
	425 x 22.5	New Recap	36000	4069		31931	31931
	425 x 22.5	New Truck	36000	4069		31931	31931
	425 x 22.5	Used Truck	36000	4093		31907	31907
	425 x 22.5	New Recap	36000	4093		31907	31907
	425 x 22.5	New Truck	36000	4093		31907	31907
	445/50 x 22.5	New Recap	36000	2893		33107	33107
	445 x 22.5	New Truck	36000	2893		33107	33107
400 / 55 x 22.5	16 Ply	36000	3685		32315	32315	
505RF (22 ton)	16.5 x 16.1	10 Ply	31200	5465		25735	25735
	19L x 16.1	10 Ply	36000	5591		30409	30409
	21.5 x 16.1	14 Ply	44000	5699		38301	38301
	425 x 22.5	Used Truck	72000	6413		65587	37587
	425 x 22.5	New Recap	72000	6413		65587	37587
	425 x 22.5	New Truck	72000	6413		65587	37587
	445/50 x 22.5	New Recap	72000	5213		66787	38787
	445 x 22.5	New Truck	72000	5213		66787	38787
	400 / 55 x 22.5	16 Ply	46920	6005		40915	37995
	560 / 45 x 22.5	16 Ply	57840	5225		52615	52615

Note: If there is a platform or bin attached to the wagon that weight must also be subtracted from the 'Payload'.
continued

Running Gear Model	Tire Options		All weights are in lbs					
			Wagon GVWR based on Tire Capacity x # Axles	-	Curb Weight Chassis + tire & rim Weight	=	Payload Travel speed rating - Low max 30 km/h (20 mile/h)	Payload Travel speed rating - High max 50 km/h (30 mile/h)
Wagon	Tire Size	Tire Type						
208 Quad (16 ton)	12.5L x 16	14 Ply	32000		2395		29605	29605
	12.5L x 15	F Range / Hwy Ser.	32000		2579		29421	29421
	14L x 16.1	8 Ply	30880		2595		28285	28285
	14L x 16.1	12 Ply	32000		2715		29285	29285
	16.5 x 16.1	10 Ply	32000		2955		29045	29045
	11 x 22.5	Used Truck	32000		3395		28605	28605
	11 x 22.5	New Recap	32000		3395		28605	28605
	12 or 315 x 22.5	Used Truck	32000		3523		28477	28477
	12 or 315 x 22.5	New Recap	32000		3523		28477	28477
	305 x 22.5	Used Truck	32000		3619		28381	28381
	305 x 22.5	New Recap	32000		3619		28381	28381
	385 x 22.5	Used Truck	32000		3883		28117	28117
	385 x 22.5	New Recap	32000		3883		28117	28117
	425 x 22.5	Used Truck	32000		4163		27837	27837
	425 x 22.5	New Recap	32000		4163		27837	27837
425 x 22.5	New Truck	32000		4163		27837	27837	
308 Quad (20 ton)	14L x 16.1	8 Ply	30880		3055		27825	27825
	14L x 16.1	12 Ply	37440		3175		34265	34265
	16.5 x 16.1	10 Ply	40000		3415		36585	36585
	19L x 16.1	10 Ply	40000		3583		36417	36417
	21.5 x 16.1	14 Ply	40000		3727		36273	36273
	11 x 22.5	Used Truck	40000		3855		36145	36145
	11 x 22.5	New Recap	40000		3855		36145	36145
	12 or 315 x 22.5	Used Truck	40000		3983		36017	36017
	12 or 315 x 22.5	New Recap	40000		3983		36017	36017
	305 x 22.5	Used Truck	40000		4079		35921	35921
	305 x 22.5	New Recap	40000		4079		35921	35921
	385 x 22.5	Used Truck	40000		4367		35633	35633
	385 x 22.5	New Recap	40000		4367		35633	35633
	425 x 22.5	Used Truck	40000		4647		35353	35353
	425 x 22.5	New Recap	40000		4647		35353	35353
	425 x 22.5	New Truck	40000		4647		35353	35353
	425 x 22.5	Used Truck	40000		4679		35321	35321
	425 x 22.5	New Recap	40000		4679		35321	35321
	425 x 22.5	New Truck	40000		4679		35321	35321
	445 x 22.5	Used Truck	40000		4839		35161	35161
445/50 x 22.5	New Recap	40000		4679		35321	35321	
445 x 22.5	New Truck	40000		4839		35161	35161	
400 / 55 x 22.5	16 Ply	40000		4135		35865	35865	
608 Quad (40 ton)	425 x 22.5	Used Truck	80000		5684		74316	74316
	425 x 22.5	New Recap	80000		5684		74316	74316
	425 x 22.5	New Truck	80000		5684		74316	74316
	445 x 22.5	Used Truck	80000		5844		74156	74156
	445/50 x 22.5	New Recap	80000		5684		74316	74316
	445 x 22.5	New Truck	80000		5844		74156	74156
	400 / 55 x 22.5	16 Ply	62560		5140		57420	57420
560 / 45 x 22.5	16 Ply	77120		5556		71564	71564	
308RF (20 ton)	14L x 16.1	8 Ply	30880		3950		26930	26930
	14L x 16.1	12 Ply	37440		4070		33370	33370
	16.5 x 16.1	10 Ply	40000		4310		35690	35690
	19L x 16.1	10 Ply	40000		4478		35522	35522
	21.5 x 16.1	14 Ply	40000		4622		35378	35378
	11 x 22.5	Used Truck	40000		4750		35250	35250
	11 x 22.5	New Recap	40000		4750		35250	35250
	12 or 315 x 22.5	Used Truck	40000		4878		35122	35122
	12 or 315 x 22.5	New Recap	40000		4878		35122	35122
	305 x 22.5	Used Truck	40000		4974		35026	35026
	305 x 22.5	New Recap	40000		4974		35026	35026
	385 x 22.5	Used Truck	40000		5262		34738	34738
	385 x 22.5	New Recap	40000		5262		34738	34738
	425 x 22.5	Used Truck	40000		5542		34458	34458
	425 x 22.5	New Recap	40000		5542		34458	34458
	425 x 22.5	New Truck	40000		5542		34458	34458
	425 x 22.5	Used Truck	40000		5574		34426	34426
	425 x 22.5	New Recap	40000		5574		34426	34426
	425 x 22.5	New Truck	40000		5574		34426	34426
	445 x 22.5	Used Truck	40000		5734		34266	34266
445/50 x 22.5	New Recap	40000		5574		34426	34426	
445 x 22.5	New Truck	40000		5734		34266	34266	
400 / 55 x 22.5	16 Ply	40000		5030		34970	34970	

Note: If there is a platform or bin attached to the wagon that weight must also be subtracted from the 'Payload'.

continued

Running Gear Model		Tire Options		All weights are in lbs				
Wagon	Tire Size	Tire Type	Wagon GVWR based on Tire Capacity x # Axles	-	Curb Weight Chassis + tire & rim Weight	=	Payload Travel speed rating - Low max 30 km/h (20 mile/h)	Payload Travel speed rating - High max 50 km/h (30 mile/h)
TR505 (20 ton)	16.5 x 16.1	10 Ply	20800		3340		17460	17460
	19L x 16.1	10 Ply	24000		3424		20576	20576
	21.5 x 16.1	14 Ply	31400		3496		27904	27904
	425 x 22.5	Used Truck	40000		3972		36028	32028
	425 x 22.5	New Recap	40000		3972		36028	32028
	425 x 22.5	New Truck	40000		3972		36028	32028
	445 x 22.5	Used Truck	40000		4052		35948	31948
	445/50 x 22.5	New Recap	40000		3972		36028	32028
	445 x 22.5	New Truck	40000		4052		35948	31948
	400 / 55 x 22.5	16 Ply	31280		3700		27580	27580
	560 / 45 x 22.5	16 Ply	38560		3948		34612	32052
	TR605 (24 ton)	425 x 22.5	Used Truck	48000		5107		42893
425 x 22.5		New Recap	48000		5107		42893	42893
425 x 22.5		New Truck	48000		5107		42893	42893
445 x 22.5		Used Truck	48000		5187		42813	42813
445/50 x 22.5		New Recap	48000		5107		42893	42893
445 x 22.5		New Truck	48000		5187		42813	42813
400 / 55 x 22.5		16 Ply	31280		4835		26445	26445
560 / 45 x 22.5		16 Ply	38560		5043		33517	33517

Note: If there is a platform or bin attached to the wagon that weight must also be subtracted from the 'Payload'.

INDEX

A		
ANSI S648	26	
AUTO LOCK	19	
B		
BACKING A FOUR WHEEL STEER	25	
BRAKE	11, 42, 43	
BRAKE FLUID	11, 42, 44	
BRAKE PAD	42, 43	
BRAKE SAFETY	11	
C		
CAUTION	7	
CHOCK	10, 31, 34	
COMPONENT CAPACITY	12	
CURB WEIGHT	49	
D		
DAMAGED LABELS	13	
DANGER	7	
E		
EP2 GREASE	35	
EXTENDABLE TONGUE	19, 21	
G		
GREASE ZERKS	37, 38, 39, 40	
GVWR	4, 12, 16, 17, 18, 29, 31, 32, 33, 49	
H		
HITCH PIN	12, 22	
I		
IMPORTANT	7	
ISO 5676	26, 33	
M		
MACHINE RUNAWAY HAZARD	21	
MAXIMUM ROAD SPEED	5	
P		
PAYLOAD	49	
PINCH POINT	23, 26, 33	
PINCH POINT HAZARD	7, 21, 22, 23, 24	
PPE	1, 8, 10, 11, 13, 23, 31, 35, 37	
Q		
QUALIFIED PERSONNEL	35, 36, 37, 38, 39, 41, 42, 43	
R		
RUNAWAY HAZARD	32	
S		
SAFETY ALERT	7	
SAFETY CHAIN	10, 12, 13, 21, 27, 31, 32	
SAFETY HAZARD	7	
SAFETY HAZARD EXPLANATION	7	
SAFETY LABEL	7	
SAFETY MESSAGE BOX	7	
SAFETY TERM	7	
SIS	5, 32	
SMV	5, 31, 32	
SPINDLES	37	
STEERING PIVOT	37	
T		
TIRES	10, 12, 46	
TRACKING ALIGNMENT	41	
TRACTOR	5	
TRAVEL SPEED RATING	4, 5, 13	
TRAVEL SPEED RATING - HIGH	5, 12	
TRAVEL SPEED RATING - LOW	5, 12	
U		
US FEDERAL REGULATION 49CFR PART 562	5	
W		
WAGON GVWR	49	
WARNING	7	
Y		
YOU ARE THE KEY TO SAFETY	8	



HORST WELDING
8082 Rd 129
Listowel, ON N4W 3G8
Canada
519-291-4162
1-866-567-4162
Fax 1-519-291-5388
sales@horstwelding.com
www.horstwelding.com